

V-Series 80 Qt. Mixer

The kitchen workhorse, for a wide range of heavy-duty mixing applications.



MODELS

- V80** 80 qt. Standard **V80PL** 80 qt. Power Lift

STANDARD FEATURES

- Stainless steel top cover, planetary cover, bayonet shaft, bowl guard and legs
- IP32 rated
- Powerful 4 HP motor with variable speed drive and agitator speed range from 47 RPMs to 257 RPMs
- #12 attachment hub with 198 RPM speed
- No bowl adapters required for down-sizing bowls
- Hydraulic damper for easier bowl lowering, and single lever manually raises bowl and locks into position
- Front-mounted controls with 90-minute timer and emergency stop with power bowl lift for V80PL only
- Durable powder coated finish on legs and outer surfaces not constructed of stainless steel
- High torque transmission
- Permanently lubricated planetary head & attachment hub case
- Bowl scraper bracket affixes to planetary head
- Grease lubricated, anti-friction ball bearings
- Patent-pending interlock prevents operation if guard is opened or bowl is lowered
- Overload protection and no volt release
- Non-skid rubber feet
- 6 foot cord
- ETL and NSF listed
- Made in Denmark

STANDARD ACCESSORIES

- Stainless steel bowl
- Aluminum flat beater
- Stainless steel wire whip
- Stainless steel dough hook

WARRANTY

- Two-year parts and labor limited warranty

OPTIONAL ACCESSORIES/ATTACHMENTS

- 40 qt. bowl and attachments
- Bowl scraper - 80 qt. or 40 qt. options
- Bowl truck
- Stainless steel model
- Marine model

To select options see back



ETL listed
Conforms to UL Std 763
Certified to CSA Std C22.2 No. 195

Approved by: _____

Date: _____

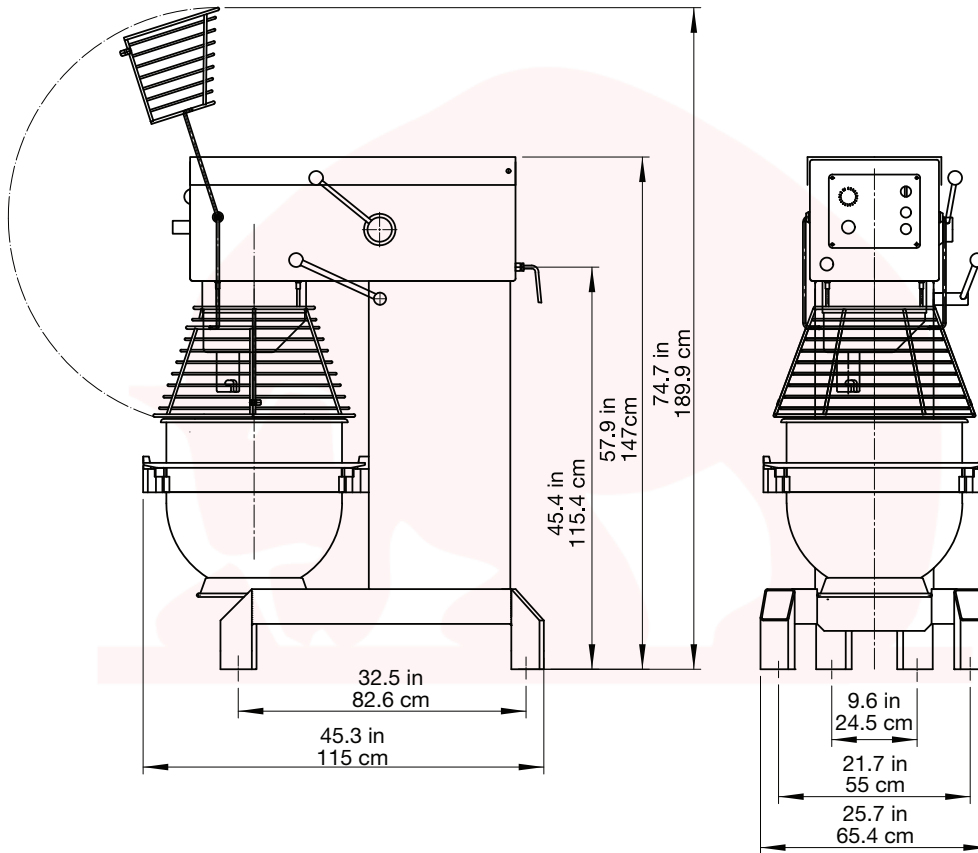

SPECIFICATIONS

Model	Motor	Volts	Amp	Plug Type	Mixing Speeds	Hub Speeds	IP Rating
V80	4 HP	208/60/3	13	--	47 - 257 RPMs	198 RPMs	IP32
V80PL	4 HP	208/60/3	13	--	47 - 257 RPMs	198 RPMs	IP32

Delivered without plug. Specify voltage when ordering.

DIMENSIONS | SHIPPING INFORMATION

Reinforced carton for shipping. This product ships on a pallet. See dimensions below.

Model	Overall Dimensions	Net Wt.	Shipping Dimensions	Ship Wt.	Freight Class
V80	27.5" W x 44.5" D x 58" H	750 lbs.	33" W x 49" D x 70" H	890 lbs.	85
V80PL	(69.85 cm x 113.03 cm x 147.32 cm)	(340 kg)	(83.82 cm x 124.4 cm x 177.8 cm)	(403.7 kg)	65 CU ft.

OPTIONAL/ADDITIONAL ACCESSORIES

- VBOWL40-80 40 qt. bowl
- VWHIP-40 40 qt. wire whip
- VSCRP-40 40 qt. scraper
- VWINGWHIP40-80 40 qt. wire whip
- VSCRP-80 80 qt. scraper
- XMCA-SS Meat grinder hub assembly
- VWINGWHIP-80 80 qt. wire whip
- XSVGH Slicer/Shredder housing
- VTRUCK-80 Bowl truck
- XSP Slicing plate
- VHOOK40-80 40 qt. hook
- L00783 Strip cutter
- VBEAT40-80 40 qt. beater
- L00670 Meat tenderizer

Product	Attachment	V80 / V80PL
Bread Dough (65% AR)	Hook	105 lbs.
Pizza Dough (50% AR)	Hook	90 lbs.
Mashed Potatoes	Whip / Beater	58 lbs.
Whipped Cream	Whip	16 qts.
Pancake Batter	Whip / Beater	35 qts.
Cookie Dough	Beater / Hook	68 lbs.

Heavy-duty 80 qt. mixer with 4 HP motor and variable speed drive with agitator speed range from 47 to 257 RPMs. #12 attachment hub with 198 RPM speed. Stainless steel top cover, bayonet shaft and bowl guard. Non-stainless steel surfaces powder coated finish. Front-mounted controls with 90-minute digital timer. Power bowl lift (V80PL) or bowl lowering lever with hydraulic damper (V80). Permanently lubricated planetary head & attachment hub case. 6 ft. cord. IP32 rated with ETL and NSF certification. Two-year parts & labor limited warranty.