



**BAKERS
PRIDE**



OPERATION MANUAL

HEARTBAKE SERIES COUNTERTOP DECK OVENS

SERIES: DP, BK, PX, & P-18, 22, 24, 44, 46, 48



BUILT BY CRAFTSMEN. TESTED BY TIME®



COUNTERTOP ELETRIC OVENS

Series:

PX-14, PX-16, P-18, BK-18, P-22S, P-22BL, P-24S, P-44S, P-44BL, P-46S, P-48S, DP-2

All gas operated Bakers Pride® ovens are intended for use with the type of gas specified on the rating plate and for installation will be in accordance with National Fuel Gas Code ANSI Z223.1 (latest edition).

Please retain this manual for future references.

⚠ WARNING

FOR YOUR SAFETY: Do not store or use gasoline or other flammable vapors or liquids in the vicinity of this or any other appliance.

⚠ WARNING

California Residents Only

WARNING: This product can expose you to chemicals including chromium which is known to the State of California to cause cancer and birth defects or other reproductive harm. For more information go to www.P65Warnings.ca.gov.

⚠ CAUTION

Improper installation, adjustment, alteration, service or maintenance can cause property damage, injury or death. Read the installation, operating and maintenance instructions thoroughly before installing or servicing this equipment.

NOTICE

Only Pizza or Bread can have direct contact with Fibrament decks. All other food products must be placed in a pan or container to avoid direct contact with ceramic decks.

This equipment is design engineered for commercial use only.



BAKERS PRIDE OVEN COMPANY, LLC.

265 Hobson St. • Smithville, TN 37166

Phone: 800.527.2100 | bakerspride.com



TABLE OF CONTENTS

ITEM	PAGE	ITEM	PAGE
SAFETY PRECAUTIONS	1	P Series - 1 Chamber - 3 Ph, 4 W - Star (Wiring Diagram)	8
INSTALLATION INSTRUCTIONS	2	P Series - 1 Chamber - 1 Ph, 2 W or 3 Ph, 3 W (Wiring Diagram)	9
Minimum Clearance for Installation	2	P Series Countertop Ovens - 2 Chamber (Schematic)	10
Location	2	P Series Counter Top Ovens - 1 Chamber (Schematic)	10
Electrical Connections	2	PX-14 & PX-16 (Wiring Diagram & Tables)	11
Requirements for Installation	2		
Initial Start Up	2	EXPLODED VIEWS & PARTS LISTS	
OPERATING INSTRUCTIONS	3	PX -14, PX-16 (New Style)	12
General Baking	3	PX -14, PX-16 (Old Style)	13
General Baking Tips	3	P18-S & BK18	14
Special Features	4	P-22BL, P-22S & P-24S	16
Cleaning	4	P-44S, P-44BL & P-48S	18
Service and Trouble Shooting	4	DP-2	20
Installation of Decks	5	WARRANTY	22
WIRING DIAGRAMS & SCHEMATICS	6		
P Series - 2 Chamber - 1 Ph, 2 W or 3 Ph, 3 W (Wiring Diagram)	6		
P Series - 2 Chamber - 3 Ph, 4 W - Star (Wiring Diagram)	7		

SAFETY PRECAUTIONS

⚠ DANGER

This symbol warns of imminent hazard which will result in serious injury or death.

⚠ WARNING

This symbol refers to a potential hazard or unsafe practice, which could result in serious injury or death.

⚠ CAUTION

This symbol refers to a potential hazard or unsafe practice, which may result in or moderate injury or product or property damage.

NOTICE

This symbol refers to information that needs special attention or must be fully understood even though not dangerous.



INSTALLATION INSTRUCTIONS

Minimum Clearance for Installation

From combustible or non-combustible construction:
Right side, Left side and Back: 3" (76mm)

Location

Due to the heat a countertop oven may produce, it must be placed on a non-combustible surface. Do not store combustible materials on top of any oven.

Electrical Connections

Suitable means, which will disconnect all ungrounded conductors of the circuit simultaneously, must be provided by the installer.

Make sure electrical supply corresponds with that specified on the rating plate located in the rear of the oven.

When installed, the unit must be connected by an earthing cable to all other units within the complete installation and thence to an independent earth connection.

Use copper conductors only, rated at 90° C.

If a line cord is used for the installation of the unit in Europe, it should be a minimum of H07RN-F type conforming to EN60 335-1 and/or local codes.

Use minimum conductor size as below:

- For models PX-14, PX-16, P-18, BK-18 and P-24S: 14 Gauge (1.5mm) for 220-240V, single phase supply.
- For models P-22S, P-22BL, P-44S, P-44BL, P-46S, P-48S and DP-2: 10 Gauge (2.5mm) for 220-240/380-415V, 3 phase supply.

Requirements For Installation

For portable units (Model PX-14 and PX-16) there are no special requirements.

For shipping purposes the optional 4" (100mm) legs are not mounted. For mounting legs, follow steps a - g.

- Remove the outer shipping carton and paper and place the oven on the floor or other flat surface.
- Remove legs, baking decks and any other materials from inside the unit.

- With sufficient help, tilt the unit back far enough to mount the two front legs and tighten with an adjustable wrench.
- After the front legs are tight, lift rear of unit approximately 5" (125mm) off the surface and block in position using wood or some other solid material. Now mount the two rear legs and tighten.
- Using the proper lifting equipment, move the unit to its final location.
- Adjust the bottom portion of legs to make level.
- Slide baking decks into each shelf. (See Installation of Decks on Page 5.)

Initial Start Up

After the electrical connections have been made, the oven will need approximately 2 to 3 hours to burn off.

CAUTION

Overexposure to smoke or fumes may cause nausea and dizziness.

Initial heating of the oven may generate smoke or fumes and must be done in a well ventilated area.

For initial heating of the new oven, follow the steps below:

- Place the oven in a well ventilated area.
- Open the oven doors and remove any instructions or samples shipped within the unit. Make sure the oven cavity is empty and the baking decks are properly installed.
- With the oven doors open, turn the temperature knobs to 400° F (205° C) for one hour. Close the oven door. Increase the temperature to 500° F (260° C) for at least 1 1/2 hours.

This procedure will dry out the insulation and deck material and will help to insure optimum baking results thereafter.



OPERATING INSTRUCTIONS

NOTICE

Only Pizza or Bread can have direct contact with Fibrament decks. All other food products must be placed in a pan or container to avoid direct contact with ceramic decks.

General Baking

Models: P-18, BK-18, P-22S, P-22BL, P-24S, P-44S, P-44BL, P-46S, P-48S, PX-14 and PX-16

- Preheat the oven by setting the thermostat to the desired temperature. When the thermostat light goes out and has cycled three times, the oven is ready for use.
- These ovens have been designed to bake both fresh and frozen products. Frozen fruit pies should be taken directly from the freezer and placed into the oven. Cooking time will vary with the size of the pie, but under normal conditions a frozen pie should bake approximately in the same time as a fresh pie.
- These ovens work well for toasting, melting cheese, baking frozen entrees, roasting small meat items, etc.
- The temperature range for pizza baking is usually between 500° F (260° C) and 575° F (300° C) depending on the individual product.
- Allow the pizza to bake until the cheese bubbles and the bottoms are evenly brown. (Rotate if necessary)
- The design of the PX-14 and PX-16 is such that normal baking temperature may be too high for good results. Set the thermostat approximately 25° F (15° C) BELOW normal setting. Adjust temperature as needed.
- Do not keep the oven door open too long when loading since heat will escape, resulting in slower baking.
- When production requirements are low, keep the temperature low to prevent the bottoms from burning.

- As demand increases, temperature should be raised for faster recovery.
- Fresh dough generally requires a slightly lower baking temperature and longer bake time than defrosted pre-baked crusts.

General Baking Tips

- Pizza crusts should be fully defrosted before baking.
- Wet areas on the bottom of a pizza will cause them to stick to the deck. Avoid spills.
- For fresh dough pizza, flour or corn meal on the peel will prevent sticking and ease placement of the pizza on the deck.
- Increasing bake temperature during heavy production assists in maintaining temperature. After the rush is over, reduce temperature to prevent burning.
- Heavily topped pizzas require longer bake times at lower temperatures.
- Placing a screen under pizza will allow the top to cook without overcooking the bottom.

Frequently scrape and brush off decks to remove burned residue which can cause an off flavor to the product. Residue build-up can slow bake times. A deck scraper/brush specially designed for this available from Bakers Pride.

- Clean heavily soiled pizza decks by scraping down, brushing off, removing from oven, turning over and putting back. This procedure will burn off the decks and should be repeated every six months. DO NOT USE WATER TO CLEAN THE DECKS as this could cause the decks to crack.
- Using shiny pans or screens will produce products with light bottom color. We strongly suggest that all pans and screens be seasoned before use.



OPERATING INSTRUCTIONS

Special Features

- **Timer:** An electric timer is provided to give an audible, continuous signal at the end of a preset time up to 15 minutes (18 minutes with 50Hz supply) on pizza ovens, or 60 minutes (72 minutes with 50Hz supply) on bake ovens.
- **Optional Electronic Timer:** A Digital electronic 99 minute timer can be provided on all models to give an audible signal at the end of a pre-set time.

NOTICE

Timer does not control the oven.

- For PX-14 and PX-16 only: Individual switches are provided to turn off the top or the bottom heating element. This allows baking items that do not require direct top or bottom heat.
- For DP-2 only: Optional infinite control switches can be provided for fine balancing of top and bottom heat.

Cleaning

- Periodic cleaning is suggested to keep your oven in good shape.

CAUTION

Always Clean The Oven When It Is Cold.

- When cleaning stainless steel, always wipe in the direction of the grain. Scrapers, brushes and stainless steel cleaner can be ordered from Bakers Pride for this purpose.
- From time to time the spillage should be scraped out. For hard to clean spillage, the following is suggested
- Turn the thermostat up to the highest setting and let the oven run for 1/2 hour with the door closed.
- Allow the oven to cool down.
- Brush residue from the deck.

NOTICE

Do Not Use Water To Clean Decks. Cracking May Result.

- Stainless steel surfaces should be cleaned with Bakers Pride stainless steel cleaner.

Service and Troubleshooting

The ovens are designed to be as trouble free as possible. Keeping the oven clean is all that is normally required. All servicing should be performed by a factory authorized technician only.

However, if your oven stops operating, please check the following:

- Power supply cord is plugged into the supply receptacle.
- Power supply fuse/circuit breaker has not tripped.

If the oven still does not operate, take the following steps:

- Disconnect the power supply to the unit by removing the supply cord and/or turning off the main switch.
- Contact the factory, factory representative or an authorized service agency.

NOTICE

Infinite control switches must be in a set position (other than off) in model DP-2 with optional infinite switches, for elements to operate.

A system wiring diagram is a part of this manual and is provided on the back of the unit.

For further information and to purchase the deck scraper/brush, or stainless steel cleaner, call Bakers Pride at: (800) 527-2100WW.

OPERATING INSTRUCTIONS

Troubleshooting Chart

PROBLEM	PROBABLE CAUSE	SOLUTION
Indicator light is out	Set temperature has been reached.	Take no action. The thermostat has turned off the power to the heat control switches, indicator lamps, contactors and heating elements. When oven starts to cool, all functions will be restored.
	The infinite top and bottom heat control switches are "OFF". (DP-2 w/Infinite Switches only)	Turn switches to a position other than "OFF". This will allow indicator lamps, contactors and heating elements to operate.
	Power supply fuses or circuit breakers are blown or have been tripped.	Replace fuse or reset circuit breaker.
	Power cord is unplugged.	Plug in power cord.
No power	Power supply fuses or circuit breakers are blown or have been tripped.	Replace fuse or reset circuit breaker.
	Power cord is unplugged.	Plug in power cord.
Oven too Hot	Thermostat set too high.	Lower the thermostat setting. Allow ample time for heat to regulate.
	Thermostat may be defective.	Call local authorized Bakers Pride Service Agent.
Bottom of pies are undercooked	Bottom infinite switch set too low. (DP-2 w/Infinite Switches only)	Increase setting.
	Top Infinite switch set too high. (DP-2 w/Infinite Switches only)	Decrease setting.
Bottom of pies burn before toppings are cooked	Deck temperature too hot - especially during slow periods.	Reduce Thermostat setting by 50° - 75° below normal bake temperature. When decks cool begin cooking and immediately increase the thermostat setting by 50° - 75°.
	Bottom infinite switch set too high. (DP-2 w/Infinite Switches only).	Decrease setting.
	Bottom infinite switch set too high. (DP-2 w/Infinite Switches only).	Increase setting.
Pies cook unevenly	Areas adjacent to oven walls are generally hotter.	Rotate pies (180°), once during each bake or keep to the center of oven.

Installation of Decks

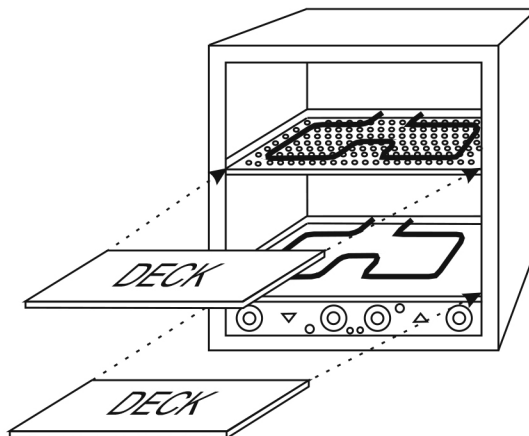

WIRING DIAGRAMS

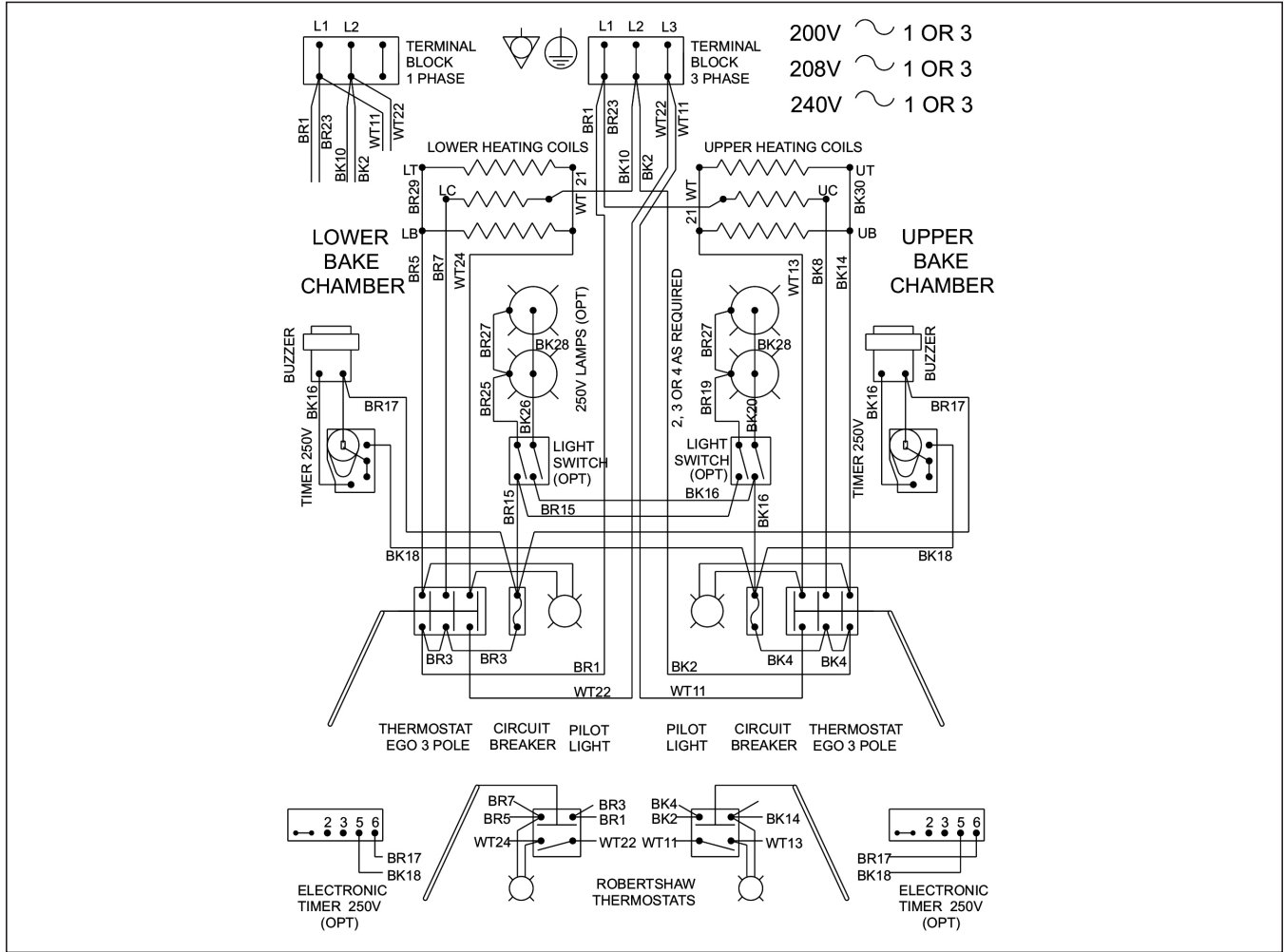

P-Series 2-Chamber - 1 PH, 2 W OR 3 PH, 3 W - Electrical Wiring Diagram & Tables

Model	1 PHASE - 2 WIRE						3 PHASE - 3 WIRE						Coil Location	Watt Per Heating Coil & Total Watt Per Unit				
	UNIT	COILS	NO L.	W.L.	USA	CAN	AMP - No Light			AMP - W. Light				DP2	P48S	P46S	P44S	P44SH
DP2	200	200	25.3	25.7	⊖	⊖	12.6	12.6	25.3	13.0	13.0	25.3	UT-UpperTop	1,075	1,075	1,075	1,075	1,075
	208	208	24.3	24.7	⊖	⊖	12.1	12.1	24.3	12.5	12.5	24.3	UC-UpperCtr	----	----	1,450	1,450	1,450
	240	230	22.0	22.3	6-30P	6-30P	11.0	11.0	22.0	11.4	11.4	22.0	UB-UpperBtm	1,450	1,075	1,075	1,075	1,450
P48S	200	200	21.5	21.9	⊖	⊖	10.8	10.8	21.5	11.2	11.2	21.5	LT-LowerTop	1,075	1,075	1,075	1,075	1,075
	208	208	20.7	21.1	⊖	⊖	10.3	10.3	20.7	10.7	10.7	20.7	LC-Lower Ctr	----	----	----	1,450	1,450
	240	230	18.7	19.0	6-30P	6-30P	9.3	9.3	18.7	9.7	9.7	18.7	LB-LowerBtm	1,450	1,075	1,075	1,075	1,450
P46S	200	200	28.8	29.4	⊖	⊖	18.0	18.0	21.5	18.6	18.6	21.5	Total No Light	5,050	4,300	5,750	7,200	7,950
	208	208	27.6	28.2	⊖	⊖	17.3	17.3	20.7	17.9	17.9	20.7	Total W. Light	5,080	4,330	5,795	7,260	8,010
	240	230	25.0	25.5	6-30P	6-50P	15.7	15.7	18.7	16.2	16.2	18.7						
P44S	200	200	36.0	36.8	⊖	⊖	25.3	25.3	21.5	26.1	26.1	21.5						
	208	208	34.6	35.4	⊖	⊖	24.3	24.3	20.7	25.0	25.0	20.7						
	240	230	31.3	32.1	6-50P	6-50P	22.0	22.0	18.7	22.7	22.7	18.7						
P44SH	200	200	39.8	40.6	⊖	⊖	27.1	27.1	25.3	27.9	27.9	25.3						
	208	208	38.2	39.0	⊖	⊖	26.1	26.1	24.3	26.9	26.9	24.3						
	240	230	34.6	35.3	6-50P	6-50P	23.6	23.6	22.0	24.3	24.3	22.0						

WIRING DIAGRAMS

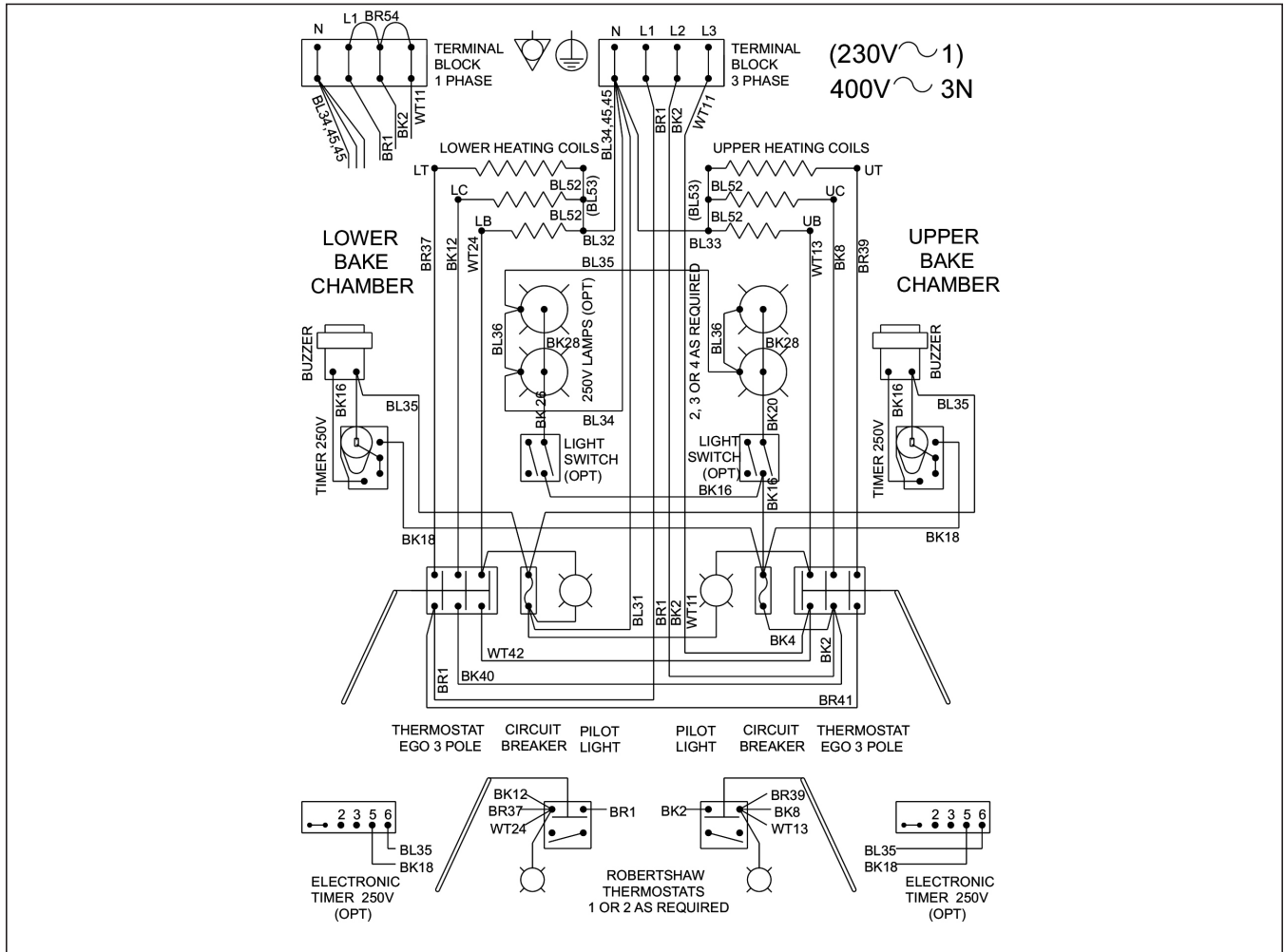

P-Series 2-Chamber - 3 PH, 4 W - Star - Electrical Wiring Diagram & Tables

Model	Volt A/C		AMP - No Light				AMP - W. Light			
	UNIT	COILS	L1	L2	L3	N	L1	L2	L3	N
DP2	230	230	22.0	---	---	22.0	22.3	---	---	22.3
	230/400	230	9.3	0.0	12.6	3.3	9.7	0.0	12.6	2.9
P48S	230	230	18.7	---	---	18.7	19.0	---	---	19.0
	230/400	230	9.3	0.0	9.3	---	9.7	0.0	9.3	0.4
P46S	230	230	25.0	---	---	---	25.5	---	---	25.5
	230/400	230	9.3	6.3	9.3	3.0	9.9	6.3	9.3	3.6
P44S	230	230	31.3	---	---	---	32.0	---	---	32.0
	230/400	230	9.3	12.6	9.3	3.3	10.0	12.6	9.3	3.3
P44SH	230	230	34.6	---	---	---	35.3	---	---	35.3
	230/400	230	9.3	12.6	12.6	3.3	10.0	12.6	12.6	2.6

Coil Location	Watt Per Heating Coil & Total Watt Per Unit				
	DP2	P48S	P46S	P44S	P44SH
UT - Upper Top	1,075	1,075	1,075	1,075	1,075
UC - Upper Ctr	----	----	1,450	1,450	1,450
UB - Upper Btm	1,450	1,075	1,075	1,075	1,450
LT - Lower Top	1,075	1,075	1,075	1,075	1,075
LC - Lower Ctr	----	----	----	1,450	1,450
LB - Lower Btm	1,450	1,075	1,075	1,075	1,450
Total No Light	5,050	4,300	5,750	7,200	7,950
Total W. Light	5,080	4,330	5,795	7,260	8,010

WIRING DIAGRAMS

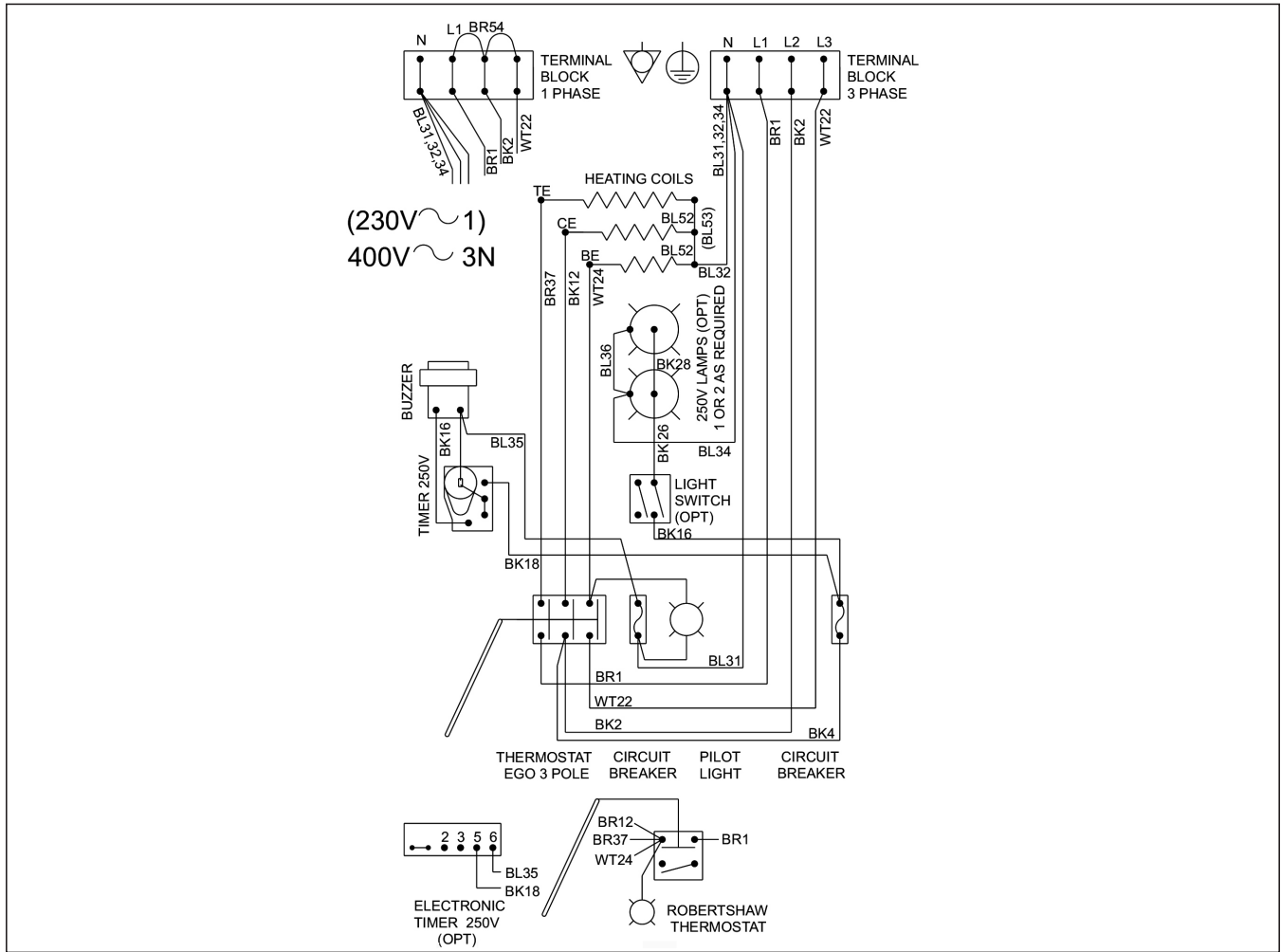

P-Series 1-Chamber 3 PH, 4W - Star - Electrical Wiring Diagram & Tables

Model	Volt A/C		AMP - No Light				AMP - W. Light			
	UNIT	COILS	L1	L2	L3	N	L1	L2	L3	N
BK18	230	230	7.4	---	---	7.4	7.6	---	---	7.6
	230/400	230	3.7	0.0	3.7	0.0	3.7	0.2	3.7	0.2
P18S	230	230	12.4	---	---	12.4	12.7	---	---	12.7
	230/400	230	3.7	4.3	4.3	0.6	3.7	4.7	4.3	1.0
P24S	230	230	9.3	---	---	9.3	9.5	---	---	9.5
	230/400	230	4.7	0.0	4.7	0.0	4.8	0.2	4.8	0.2
P22S	230	230	15.7	---	---	15.7	16.0	---	---	16.0
	230/400	230	4.7	6.3	4.7	1.4	4.7	6.7	4.7	2.0
P22SH	230	230	17.3	---	---	17.3	17.6	---	---	17.6
	230/400	230	4.7	6.3	6.3	1.6	4.7	6.7	6.3	2.0

Coil Location	Watt Per Heating Coil & Total Watt Per Unit				
	BK18	P18S	P24S	P22S	P22SH
TE -Top Element	850	850	1,075	1,075	1,075
	----	1,000	----	1,450	1,450
BE -BtmElement	850	1,000	1,075	1,075	1,450
Total No Light	1,700	2,850	2,150	3,600	3,975
Total W. Light	1,715	2,880	2,165	3,630	4,005

WIRING DIAGRAMS

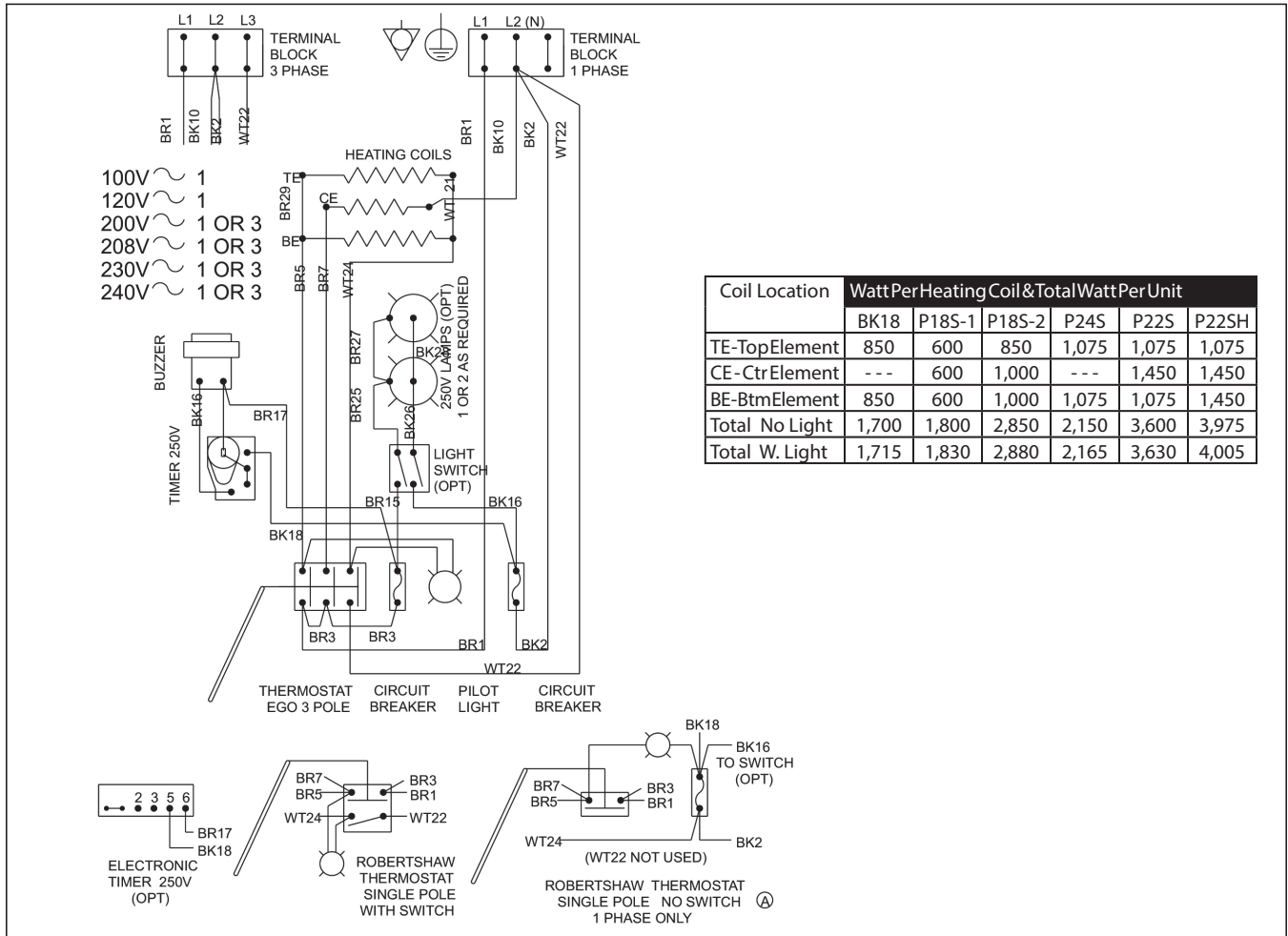

P-Series 1-Chamber 1 PH, 2W or 3 PH, 3W - Electrical Wiring Diagram & Tables

Model	Volt A/C		3 Phase 3 Wire			1 PH 2 Wire		Ampere		Plug Configuration & Number					
	UNIT	COILS	L1	L2	L3	L1	L2	L3	NO L.	W. L.	USA	CAN	JAPAN	UK	EUROPE
BK18	100	100							17.0	17.4	5-15P	5-20P	5-20P	N/A	N/A
	120	120							14.2	14.5					
	200	200	8.5	0.0	8.5	8.7	0.2	8.5	8.5	8.7	6-15P	6-15P	6-15P	BS1363A	CEE7-VII
	208	208	8.2	0.0	8.2	8.4	0.2	8.2	8.2	8.4					
	240	230	8.1	0.0	8.1	8.2	0.1	8.1	8.1	8.2					
P18S-1	100	100							18.0	18.8	5-15P	5-20P	5-20P	N/A	N/A
	120	120							15.0	N/A					
P18S-2	200	200	14.3	5.0	9.3	14.7	5.4	9.3	14.3	14.7	6-15P	6-20P	6-15P	BS1363A	CEE7-VII
	208	208	13.7	4.8	8.9	14.1	5.2	8.9	13.7	14.1					
	240	230	13.5	4.7	8.8	13.9	5.1	8.8	13.5	13.9					
P24S	200	200	10.8	0.0	10.8	11.0	0.2	10.8	10.8	11.0	6-15P	6-15P	6-15P	BS1363A	CEE7-VII
	208	208	10.3	0.0	10.3	10.5	0.2	10.3	10.3	10.5					
	240	230	10.2	0.0	10.2	10.4	0.2	10.2	10.2	10.4					
P22S	200	200	18.0	7.2	10.8	18.4	7.7	10.8	18.0	18.4	6-20P	6-30P	6-20P	N/A	N/A
	208	208	17.3	7.0	10.3	17.7	7.4	10.3	17.3	17.7					
	240	230	17.1	6.9	10.2	17.4	7.2	10.2	17.1	17.4					
P22SH	200	200	19.9	7.2	12.6	20.3	7.7	12.6	19.9	20.3	6-20P	6-30P	6-20P	N/A	N/A
	208	208	19.1	7.0	12.1	19.5	7.4	12.1	19.1	19.5					
	240	230	18.8	6.9	12.0	19.2	7.2	12.0	18.8	19.2					

WIRING DIAGRAMS

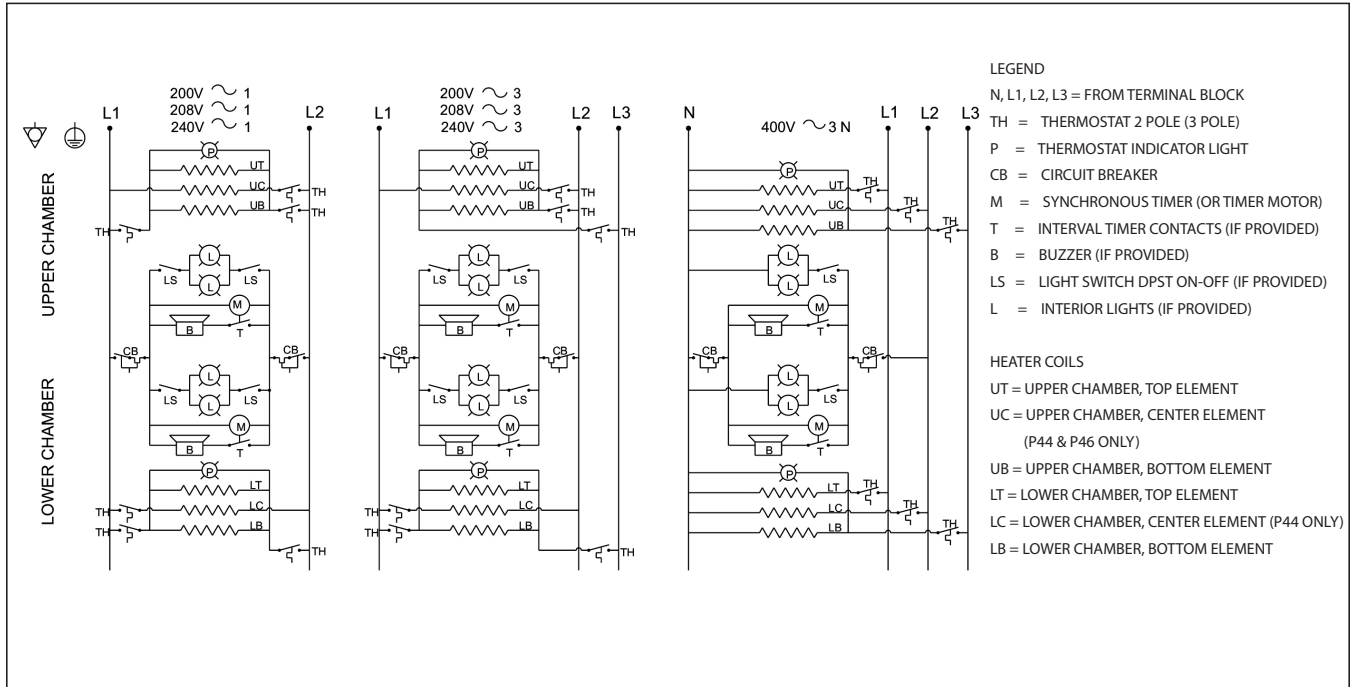

P-Series 2 Chambers – Electrical Wiring & Tables

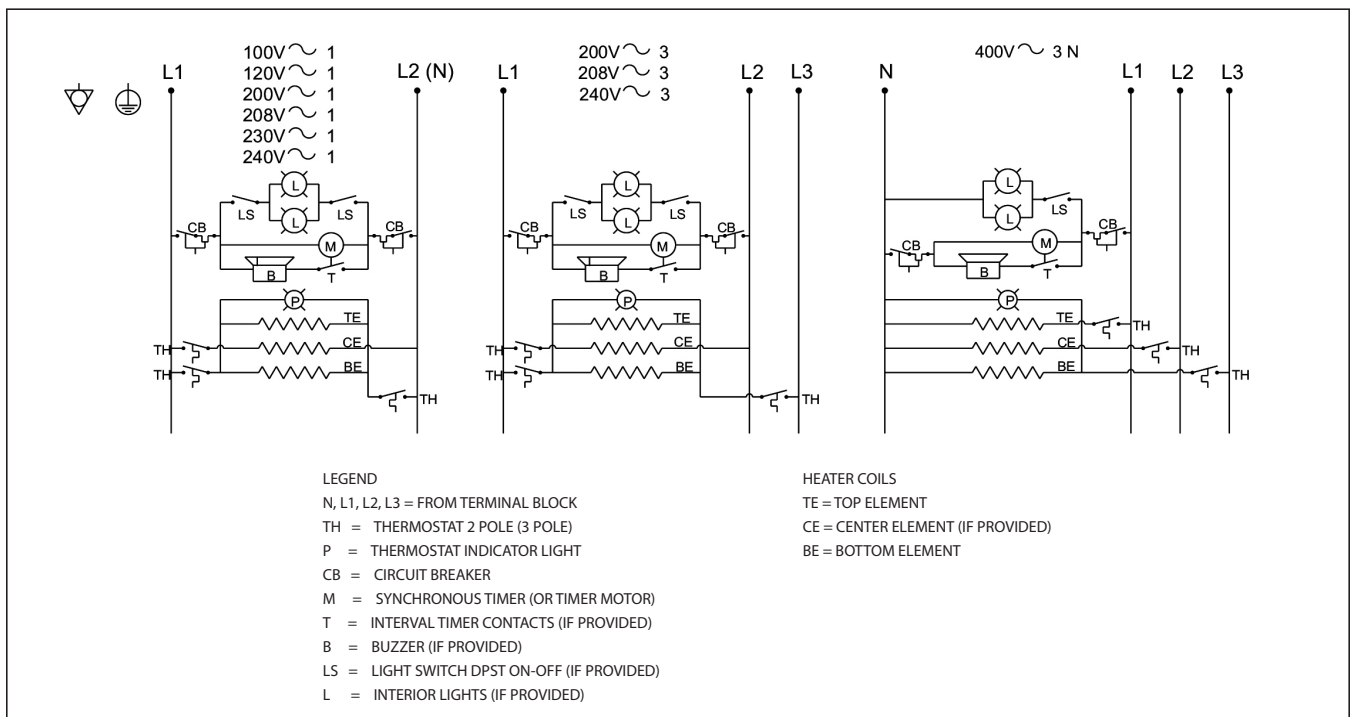





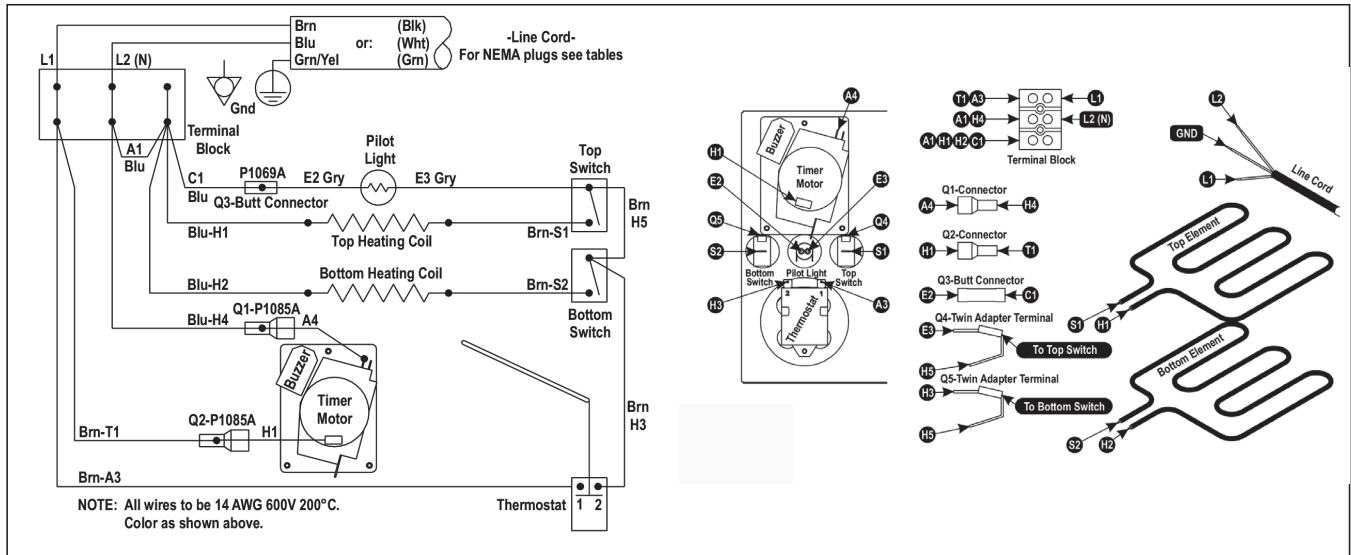



P-Series 1 Chamber – Electrical Wiring Schematics

WIRING DIAGRAMS











PX-14 & PX-16 – Electrical Wiring Diagram Tables

PX-14

Volts A/C/ Phase	AMP	NEMA Plug Configuration & Number					Heating Coils Watts/Volts	Timer Motor Volts/Hz
		USA	CANADA	UK	EUROPE	JAPAN		
100/1	15					 5-15P	750/100	120/60
120/1	12.5	 5-15P	 5-20P				750/100	120/60
200/1	7.5					 6-15P	750/200	250/60
208-240/1	8.1	 6-15P	 6-15P				750/220	250/60
220-240/1	8.1			 BS 1363A	 CEE7-VII		750/220	250/60

PX-16

Volts A/C/ Phase	AMP	NEMA Plug Configuration & Number					Heating Coils Watts/Volts	Timer Motor Volts/Hz
		USA	CANADA	UK	EUROPE	JAPAN		
100/1	18					 5-15P	900/100	125/60
120/1	15	 5-20P	 5-20P				900/100	125/60
200/1	9					 6-15P	900/200	250/60
208-240/1	9.7	 6-15P	 6-15P				900/220	250/60
220-240/1	9.7			 BS 1363A	 CEE7-VII		900/220	250/60

EXPLODED VIEWS & PARTS LISTS

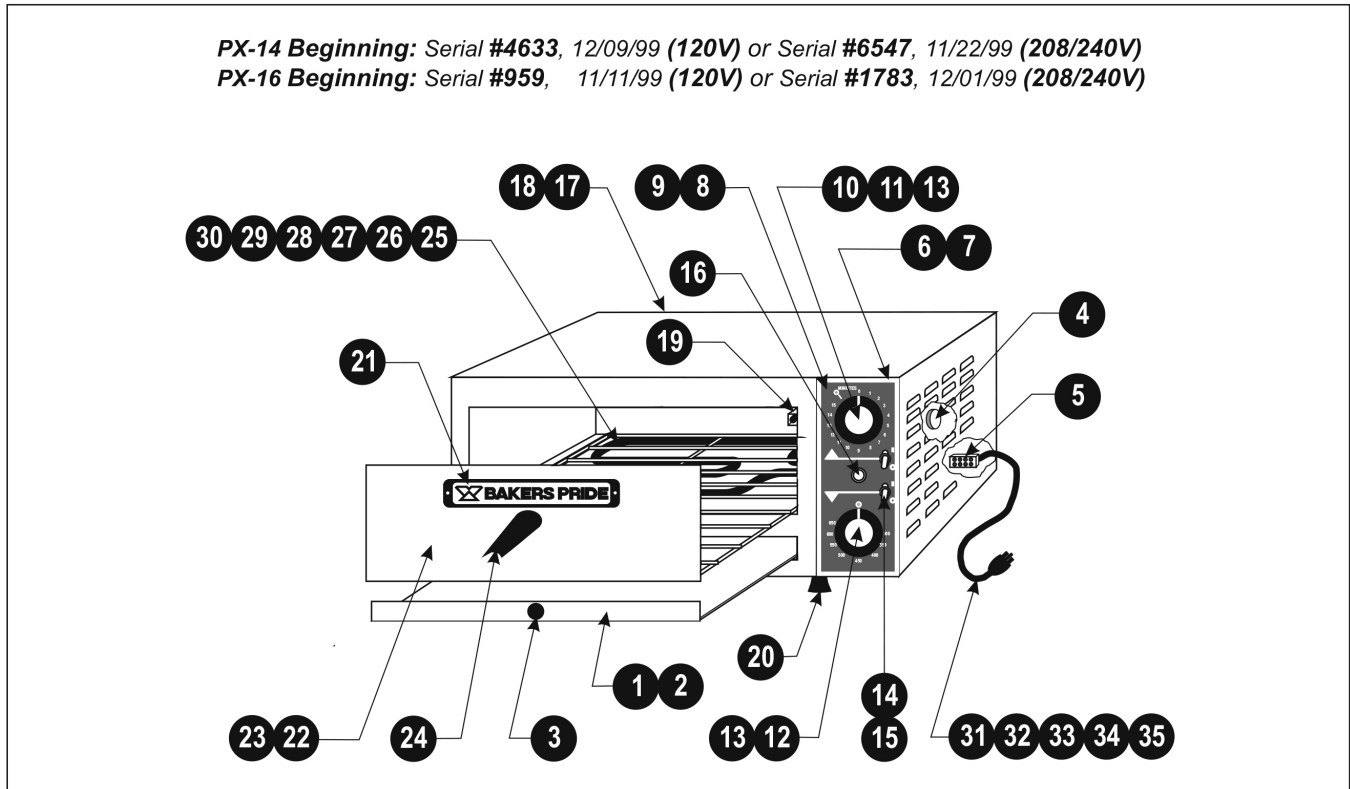

PX-14/16 New Style

Item	P/N	Description
1	D5023X	Crumb Pan Assy w/Knob (PX-14)
2	D5123X	Crumb Pan Assy w/Knob (PX-16)
3	S1153X	Knob (Crumb Pan)
4	M1335X	Audio Alarm
5	P1003X	Terminal Block, 3 Pole
6	D5027U	Control Panel Assy, Front (PX-14)
7	D5127X	Control Panel Assy, Front (PX-16)
8	U1308A	Control Panel Overlay, 60hz
9	U1309A	Control Panel Overlay, 50hz
10	M1383A	Timer, Electro-Mechanical, 15 Minutes, 120V
11	M1384A	Timer, Electro-Mechanical, 15 Minutes, 220V
12	M1119X	Thermostat, EGO, 300-650 deg (No Knob)
13	S1311X	Knob (Thermostat & Timer)
14	M1037X	Switch, Toggle, On/Off
15	S1038X	Rubber Boot, On/Off Switch (Export)
16	P1127X	Pilot Light, Amber
17	D5038U	Rear Panel Assy, (PX-14)
18	D5138U	Rear Panel Assy, (PX-16)

Item	P/N	Description
19	D5043U	Capillary Retainer Assy
20	S1392A	Leg, each
21	U1044X	Bakers Pride Nameplate, 8"
22	D5037U	Peel Tray Assy w/Wire Rack & Hdl (PX-14)
23	D5141U	Peel Tray Assy w/Wire Rack & Hdl (PX-16)
24	S1031X	Handle, w/Nut & Bolt
25	L1065X	Element, PX-14, 120V/750W (2)
26	L1148X	Element, PX-16, 120V/900W (2)
27	L1066X	Element, PX-14, 220V/750W (2)
28	L1149X	Element, PX-16, 220V/900W (2)
29	L1067X	Element, PX-14, 100V/750W (2) Japan
30	L1156X	Element, PX-16, 200V/900W (2) Japan
31	P6004X	Line Cord, 125V/15A
32	P6383A	Line Cord, 125V/20A (Canada)
33	P6005X	Line Cord, 250V/15A
34	P6006X	Line Cord, CEE7-VII (Europe)
35	P6343X	Line Cord w/Fuse, 13A/240V (U.K.)

Note: When ordering, always specify Part#, Model#, Serial# and Voltage/Phase.

EXPLODED VIEWS & PARTS LISTS

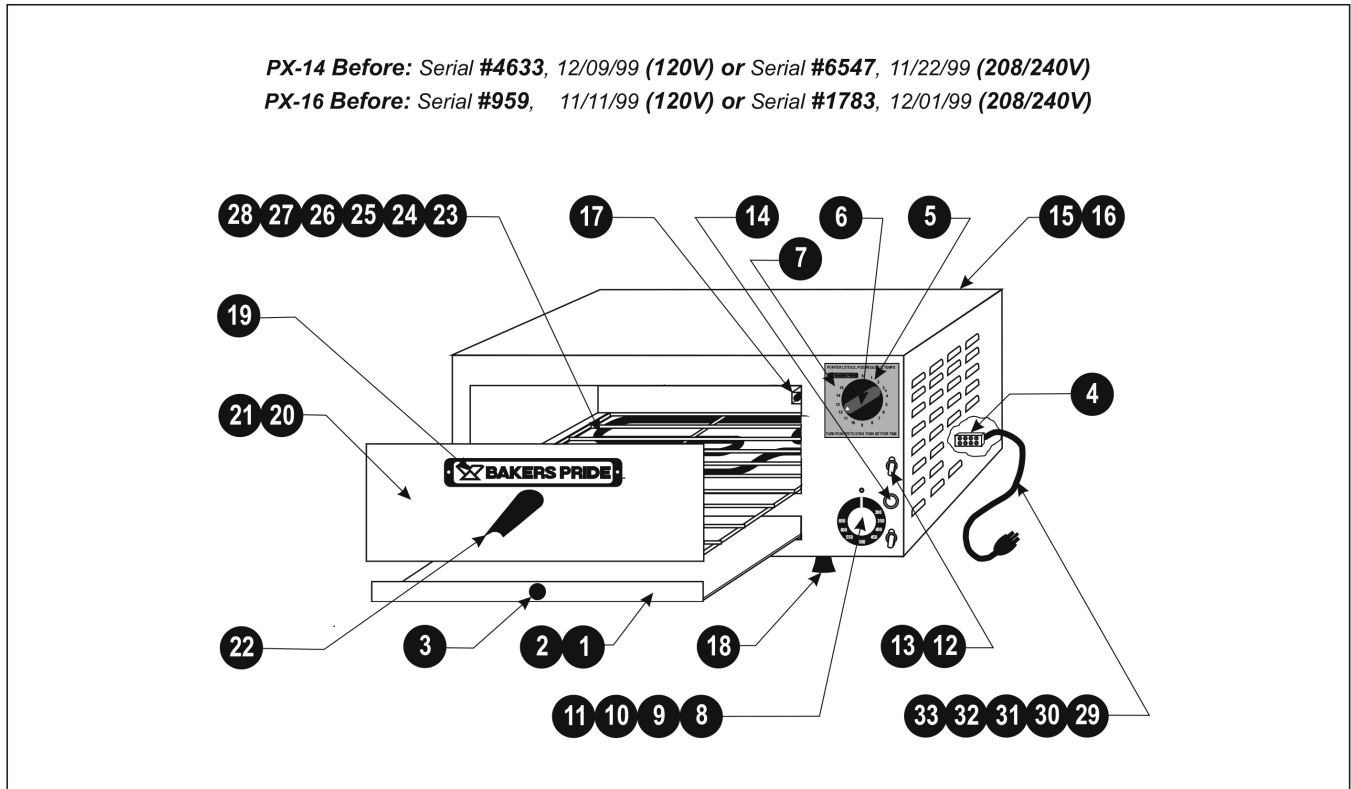

PX-14/16 Old Style

Item	P/N	Description
1	D5023X	Crumb Pan Assy w/Knob (PX-14)
2	D5123X	Crumb Pan Assy w/Knob (PX-16)
3	S1153X	Knob (Crumb Pan)
4	P1003X	Terminal Block, 3 Pole
5	M1017X	Timer, Mech, 15 Minutes (w/Knob/Plate)
6	S1052X	Knob, Timer
7	S1025X	Plate, Timer
8	M1120X	Thermostat, EGO, 650F deg (w/Knob)
9	M1119X	Thermostat, EGO, 370C deg (w/Knob)
10	S1155X	Knob, Thermostat (650F)
11	S1154X	Knob, Thermostat (370C)
12	M1037X	Switch, Toggle, On/Off
13	S1038X	Rubber Boot, On/Off Switch (Export)
14	P1127X	Pilot Light, Amber
15	D5038U	Rear Panel Assy, (PX-14)
16	D5138U	Rear Panel Assy, (PX-16)
17	D5043U	Capillary Retainer Assy
18	S1392A	Leg, each

Item	P/N	Description
19	U1044X	Bakers Pride Nameplate, 8"
20	D5037U	Peel Tray Assy w/Wire Rack (PX-14)
21	D5141U	Peel Tray Assy w/Wire Rack (PX-16)
22	S1031X	Handle, w/Nut & Bolt
23	L1065X	Element, PX-14, 120V/750W (2)
24	L1148X	Element, PX-16, 120V/900W (2)
25	L1066X	Element, PX-14, 220V/750W (2)
26	L1149X	Element, PX-16, 220V/900W (2)
27	L1067X	Element, PX-14, 100V/750W (2) Japan
28	L1156X	Element, PX-16, 200V/900W (2) Japan
29	P6004X	Line Cord, 125V/15A
30	P6383A	Line Cord, 125V/20A (Canada)
31	P6005X	Line Cord, 250V/15A
32	P6006X	Line Cord, CEE7-VII (Europe)
33	P6343X	Line Cord w/Fuse, 13A/240V (U.K.)

Note: When ordering, always specify Part#, Model#, Serial# and Voltage/Phase.



COUNTERTOP ELECTRIC OVEN OPERATION MANUAL

EXPLODED VIEWS & PARTS LISTS

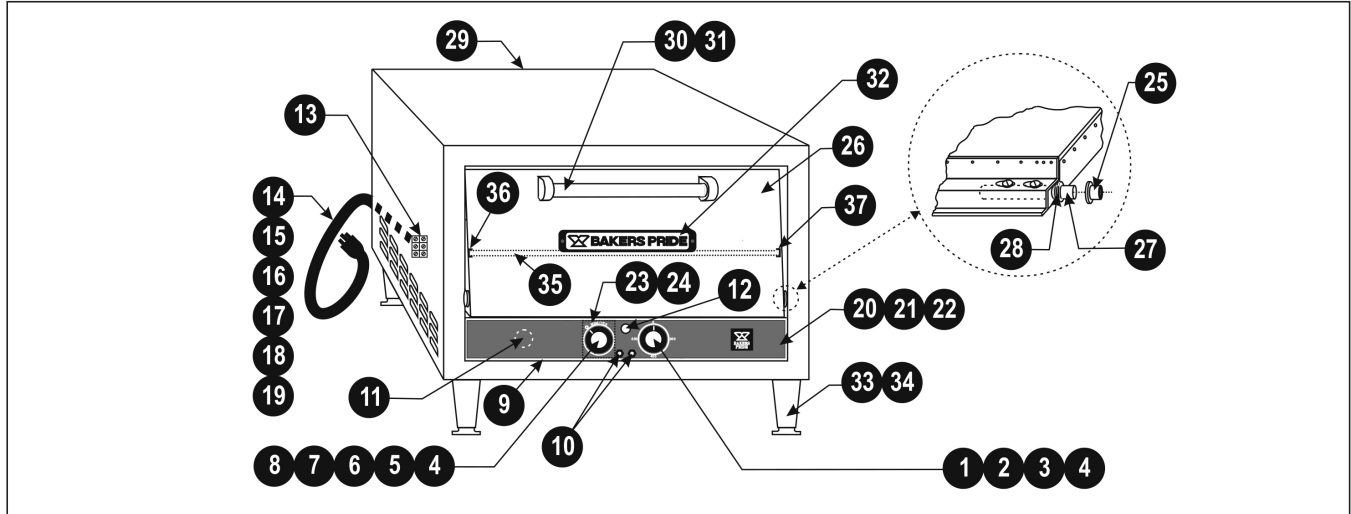

P18-S, BK18 Exterior / Door / Controls (Electro-Mechanical Timers)

Item	P/N	Description
1	M1098X	Thermostat w/Knob, EGO (Standard) P-18
2	M1192X	Thermostat w/Knob, EGO (High Heat) P-18
3	M1110X	Thermostat w/Knob, KA-72, 550deg (BK-18)
4	S1311X	Knob (Thermostat & Timer)
5	M1381A	Timer, Elec-Mech, 60 Min, 120V (BK-18)
6	M1382A	Timer, Elec-Mech, 60 Min, 220V (BK-18)
7	M1383A	Timer, Elec-Mech, 15 Min, 120V (P-18)
8	M1384A	Timer, Elec-Mech, 15 Min, 220V (P-18)
9	D3157K	Control Panel
10	M1330A	Circuit Breaker, 3 Amp
11	M1335X	Audio Alarm (Discontinued)
12	P1127X	Pilot Light, Amber
13	P1089A	Terminal Block, 3 Pole
14	P6004X	Line Cord 125V/15A (US) P & BK
15	P6005X	Line Cord 250V/15A (US & Japan) P & BK
16	P6383X	Line Cord 125V/20A (Canada)
17	P6009X	Line Cord 250V/20A (Canada)
18	P6006X	Line Cord, 230V/16A "C" Type (CE)
19	P6343X	Line Cord, 230V/13A (UK)

Item	P/N	Description
20	U1302X	Control Panel Overlay, EGO (P-18)
21	U1307A	Control Panel Overlay, EGO Hi-Heat (P-18)
22	U1314A	Control Panel Overlay (BK-18)
23	U1297A	18 Minute Timer Overlay (50 cycles)
24	U1296A	72 Minute Timer Overlay (50 cycles)
25	S3019X	Bushing, Door
26	D3106X	Door Assy w/Handle
27	S3001X	Door Rod
28	Q3021X	Door Rod Spacer Kit (1 Kit per Door)
29	D3105K	Outer Back
30	S1316U	Door Handle Assy, 10"
31	Q2041A	Screw, 1/4-20 x 1/2 Rd Hd (Door Handle)
32	U1044X	Bakers Pride Nameplate, 8"
33	S1014X	4" Adjustable Leg (Set/4)
34	S1014Y	4" Adjustable Leg (each)
35	T3150A	Intermediate Wire Rack (Option, BK18)
36	D3162U	Wire Rack Support Assy, Left (Option)
37	D3163U	Wire Rack Support Assy, Right (Option)
N/S	D2069X	Stacking Kit

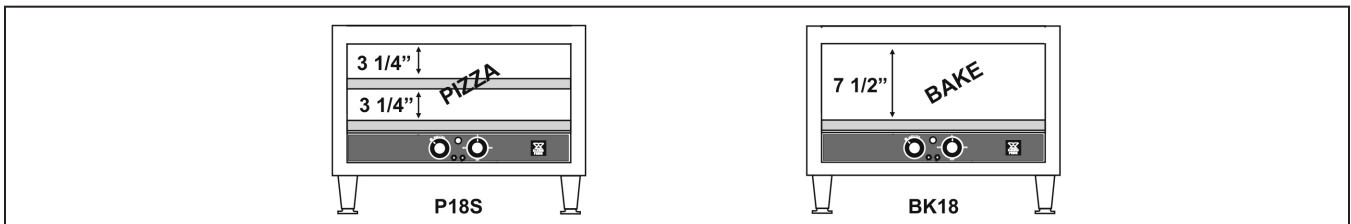

Deck Arrangement by Model

Note: When ordering, always specify Part#, Model#, Serial# and Voltage/Phase.

EXPLODED VIEWS & PARTS LISTS

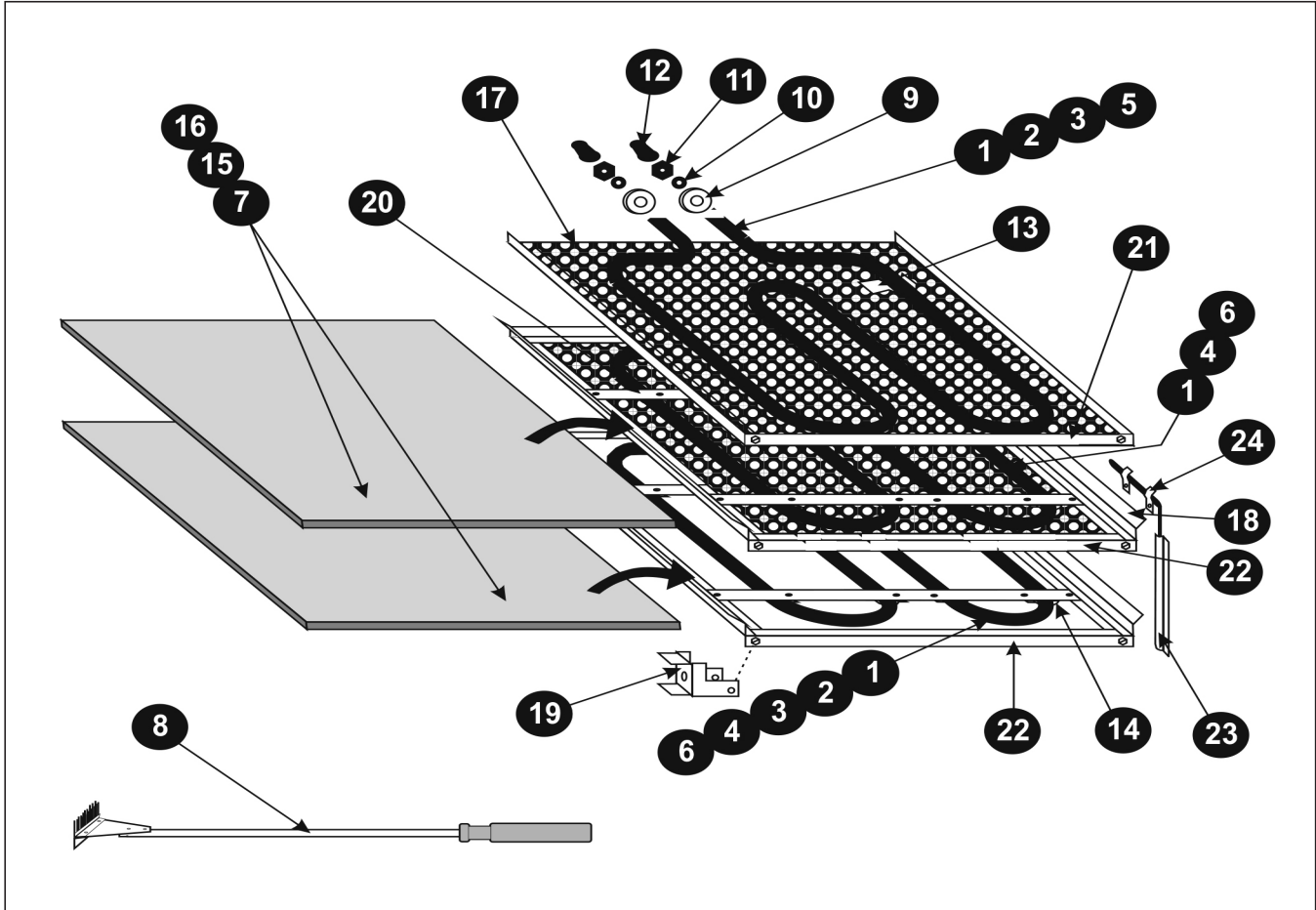

P18, BK18 Interior Components & Accessories

Item	P/N	Description
1	L1024X	Element 115V/600W (US/Can) P-18, T,C & B
2	L1171X	Element 115V/850W (US/Can) BK-18, T & B
3	L1025X	Element 208-240V/850W (US/Can/CE)P Top, BKT&B
4	L1026X	Element 208-240V/1KW (US/Can/CE) P-18 C & B
5	L1112X	Element 200V/850W (Japan) P-18 Top
6	L1113X	Element 200V/1000W (Japan) P-18 C & B
7	T5118X	Steel Bake Deck (BK18 Only)
8	T5107Y	Deck Scraper Brush
9	P1019X	Porcelain Spacer
10	Q3016A	Washer, Star, #6
11	Q1002A	Nut, 6-32
12	S1061X	6-32 Terminal Cap

Item	P/N	Description
13	K1355X	Baffle & Top Elem. Clips (5) BK
14	P1042A	Element Clip, 5/16", Center & Bottom
15	T1120Y	Ceramic Deck, 17 1/2 x 17 3/4 x 1/2 (each)
16	T1120X	Ceramic Deck, 17 1/2 x 17 3/4 x 1/2 (set/2)
17	D3140Z	Fresh Dough Baffle
18	D3152T	Hearth Frame Assy
19	D4039K	Deck Support
20	D3151K	Element Support
21	D3131K	Baffle Trim
22	D3142K	Deck Trim
23	D1134K	Capillary Cover
24	Q4021X	Clip 3/16", Temp Sensor (2)

Note: When ordering, always specify Part#, Model#, Serial# and Voltage/Phase.

EXPLODED VIEWS & PARTS LISTS

This partslist pertains to the following units			
Model	Voltage	StartingSerial#	Date
P-22BL	All	All	N/A
P-22S	208VAC	#7131	11/2/99
P-22S	208VAC	#4160	11/2/99
P-24S	All	#17288	2/29/00

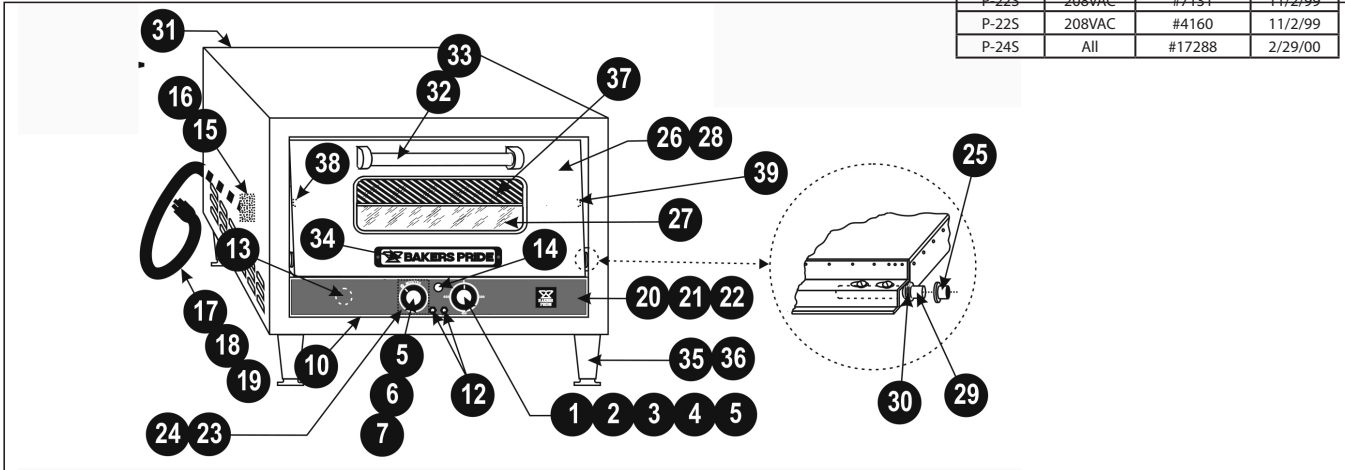

P-22BL, P-22S, P-24S Exterior / Door / Controls (Electro-Mechanical Timers)

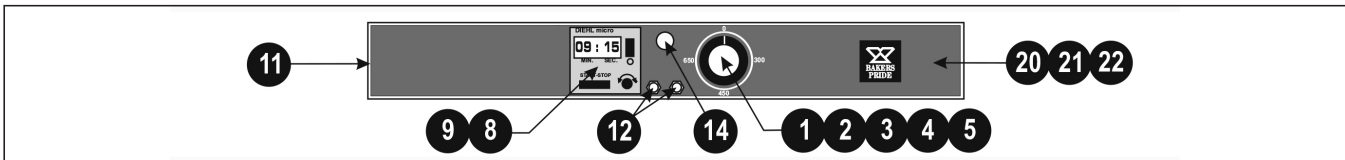

Control Panel with Digital Timer (Optional)

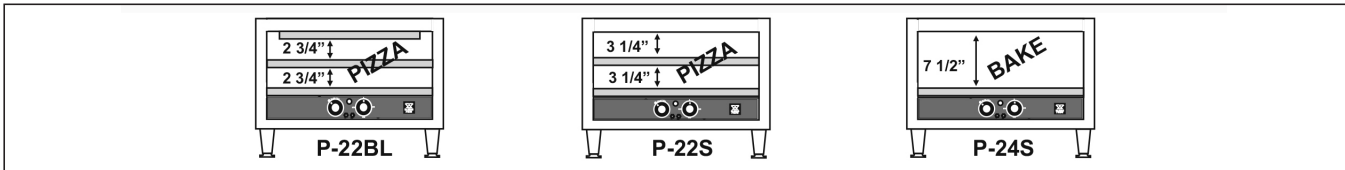

Deck Arrangement by Model

Item	P/N	Description
1	M1098X	Thermostat w/Knob, 650F (EGO)
2	M1192X	Thermostat w/Knob, CE "430C" (High Heat)
3	M1110X	Thermostat w/Knob, 550F, KA-72 (P-24S)
4	M1342X	Thermostat Kit w/Knob, 250F (Special)
5	S1311X	Knob (T-stat "F", 15 Min Timer: Rot-Elec)
6	M1384A	Timer, Electro-Mech, 15 Min, (P-22S & P-22BL)
7	M1382A	Timer, Electro-Mech, 60 Min (P-24S)
8	M1275X	Timer, Electronic (Digital Readout) 60 cycle
9	M1274X	Timer, Electronic (Digital Readout) 50 cycle
10	D1157K	Control Panel (Rot/Elect Timer)
11	D1156K	Control Panel (Electronic Timer)
12	M1330A	Circuit Breaker, 3A
13	M1335X	Audio Alarm (Discontinued)
14	P1127X	Pilot Light, Amber
15	P1003X	Terminal Block, 3 Pole, 1 Phase
16	P1004X	Terminal Block, 4 Pole, 3 Phase
17	P6009X	Line Cord, 250V/20A (USA & Canada)
18	P6385A	Line Cord, 250V/30A (Can. 208V only) P22S/BL
19	P6005X	Line Cord, 250V/15A (P-24S)
20	U1302X	Control Panel Overlay, 22S & 22BL

Item	P/N	Description
21	U1307A	Control Panel Overlay, Hi Heat, 22S & 22BL
22	U1314A	Control Panel Overlay, P-24S
23	U1297A	18 Minute Timer Overlay (50 cycle)
24	U1296A	72 Minute Timer Overlay (50 cycle)
25	S3019X	Door Bushing
26	D1106X	Door Assy (No Window)
27	S1020X	Window Assy (Door)
28	D1143U	Door Assy (w/Window)
29	S3001X	Door Rod
30	Q3021X	Door Rod Spacer Kit (1 Kit per Door)
31	D1105K	Outer Back
32	S1316U	Door Handle
33	Q2041A	Screws, 1/4-20 x 1/2 RH (Door Handle)
34	U1044X	Bakers Pride Nameplate, 8"
35	S1014X	4" Adjustable Leg (Set/4)
36	S1014Y	4" Adjustable Leg (each)
37	T3139X	Intermediate Wire Rack (Option, P-24)
38	D1162U	Wire Rack Support Assy, Left (Option)
39	D1163U	Wire Rack Support Assy, Right (Option)
40	D2069X	Stacking Kit

Note: When ordering, always specify Part#, Model#, Serial# and Voltage/Phase.

EXPLODED VIEWS & PARTS LISTS

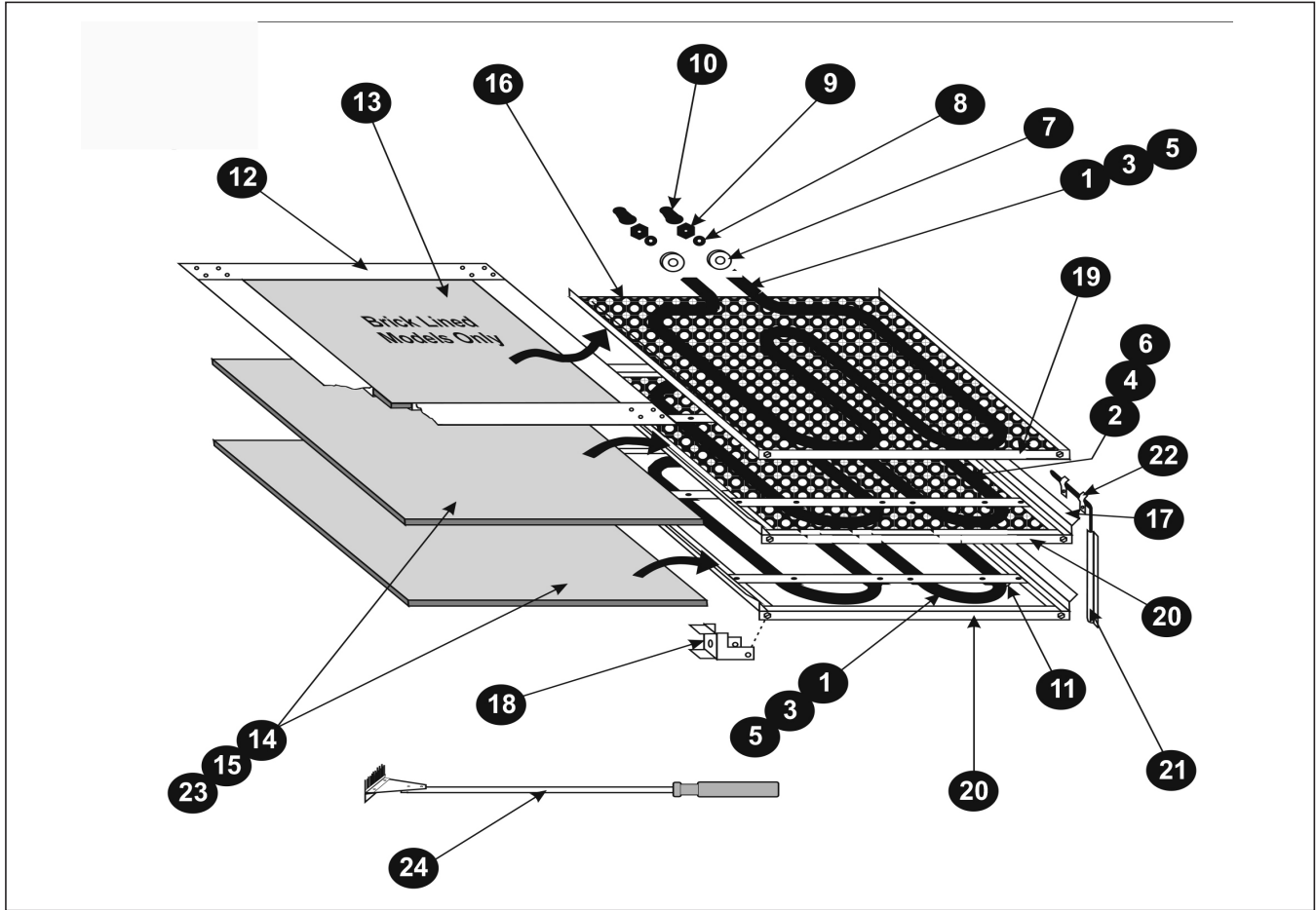

P-22BL, P-22S, P-24S Interior Components & Accessories

Item	P/N	Description
1	L1072X	Element, 208V/1075W, Top & Bottom
2	L1071X	Element, 208V/1450W, Center
3	L1035X	Element, 230V/1075W, Top & Bottom
4	L1034X	Element, 230V/1450W, Center
5	L1116X	Element, 200V/1075W, Top & Bottom (Japan)
6	L1117X	Element, 200V/1450W, Center (Japan)
7	P1019A	Porcelain Spacer
8	Q3016A	Washer, Star, #6
9	Q1002A	Nut, 6-32
10	S1061X	Terminal Cap, 6-32
11	K1355X	Element Clip
12	D1158U	Ceramic Top Frame Assy (B/L Only)

Item	P/N	Description
13	T1120Y	Deck, ea. 17 3/4 x 17 1/2 x 1/2 (P-22BL only)
14	T1121Y	Deck, 20 13/16 x 20 13/16 x 1/2 (each)
15	T1121X	Deck, 20 13/16 x 20 13/16 x 1/2 (set/2)
16	D4040X	Fresh Dough Baffle
17	D1152T	Hearth Frame Assy (No Element)
18	D4039K	Deck Support
19	D4031X	Baffle Trim
20	D1142K	Hearth Trim
21	D1134K	Capillary Cover
22	Q4021X	Clip, 3/16"
23	T1222K	Steel Bake Deck (Optional)
24	T5107Y	Deck Scraper Brush

Note: When ordering, always specify Part#, Model#, Serial# and Voltage/Phase.

EXPLODED VIEWS & PARTS LISTS

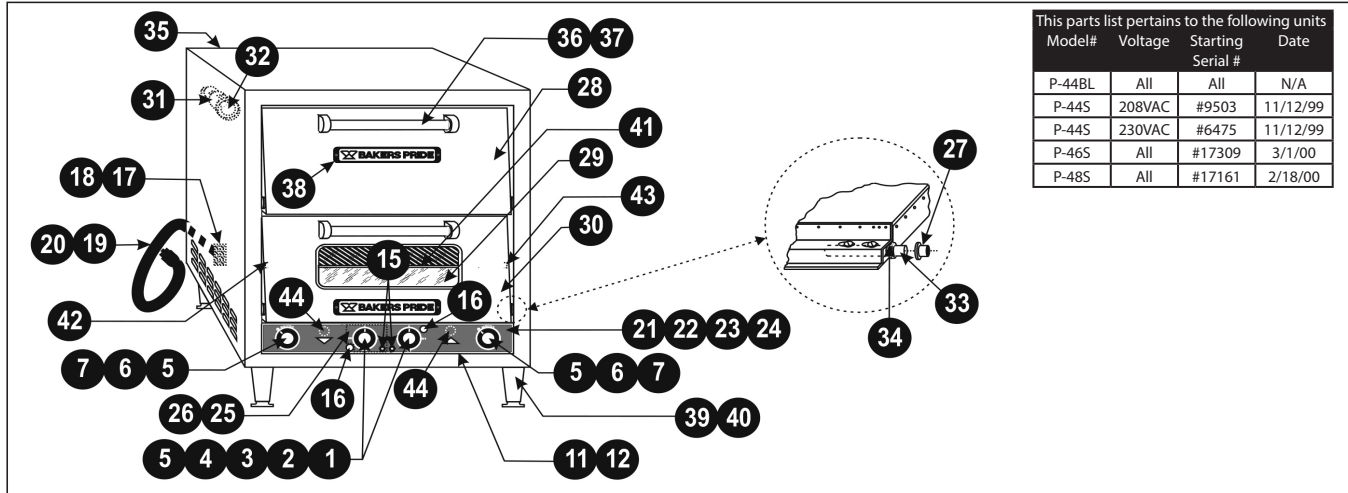

This parts list pertains to the following units

Model#	Voltage	Starting Serial #	Date
P-44BL	All	All	N/A
P-44S	208VAC	#9503	11/12/99
P-44S	230VAC	#6475	11/12/99
P-46S	All	#17309	3/1/00
P-48S	All	#17161	2/18/00

P-44S, P-44BL, P-46S, P-48S Exterior/Door/Controls (No Lights, Electro-Mechanical Timers)

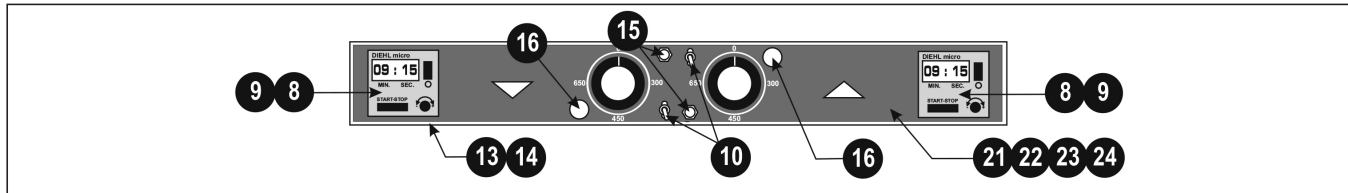

Control Panel with Lights & Digital Timers (Optional)

Item	P/N	Description
1	M1098X	Thermostat w/Knob, 650F EGO, 44(2) 46(1)
2	M1192X	Thermostat w/Knob, CE "430C" High Heat 44
3	M1342X	Thermostat Kit w/Knob, 250F (Special)
4	M1110X	Thermostat w/Knob, 550F KA72, 46 (1), 48 (2)
5	S1311X	Knob (T-stat "F", 15 Min Timer: Rot-Elec)
6	M1384A	Timer, Elec-Mech, 15 Min, 44(2) 46(1)
7	M1382A	Timer, Elec-Mech, 60 Min, 46(1) 48(2)
8	M1275X	Timer, Electronic (Digital Readout) 60 cycle
9	M1274X	Timer, Electronic (Digital Readout) 50 cycle
10	M1259X	Toggle Switch (Lights, On/Off)
11	D2157K	Control Panel (Rot/Elect Timer-No Lights)
12	D2101K	Control Panel (Rot/Elect Timer-w/Lights)
13	D2156K	Control Panel (Electronic Timer-No Lights)
14	D2102K	Control Panel (Electronic Timer-w/Lights)
15	M1330A	Circuit Breaker, 3A
16	P1127X	Pilot Light, Amber
17	P1003X	Terminal Block, 3 Pole, 1 Phase
18	P1004X	Terminal Block, 4 Pole, 3 Phase
19	P6399A	Line Cord, 125/250V, 50A
20	P6385A	Line Cord, 250V, 30A (P-46 & P-48)
21	U1304A	Control Panel Overlay (44 & 44BL)
22	U1310A	Control Panel Overlay, Hi Heat (44 & 44BL)
23	U1316A	Control Panel Overlay (P-46)
24	U1318A	Control Panel Overlay (P-48)

Item	P/N	Description
25	U1297A	18 Minute Timer Overlay (50 cycles)
26	U1296A	72 Minute Timer Overlay (50 cycles)
27	S3019X	Door Bushing
28	D1106U	Door Assy (No Window)
29	S1020X	Window Assy (Door)
30	D1143U	Door Assy (w/Window)
31	P1145X	Light Fixture (w/240V,15W Bulb)
	P1129X	Light Fixture (Old Style, 3" Diameter)
32	P1147X	Light Bulb, 240V/15W
	P1020X	Light Bulb, (Old Style, 115V)
	P1122X	Light Bulb, (Old Style, 250V)
33	S3001X	Door Rod
34	Q3021X	Door Rod Spacer Kit (1 Kit per Door)
35	D2105K	Outer Back
36	S1316U	Door Handle
37	Q2041A	Screws, 1/4-20 x 1/2 RH (Door Handle)
38	U1044X	Bakers Pride Nameplate, 8"
39	S1014X	4" Adjustable Leg (Set/4)
40	S1014Y	4" Adjustable Leg (each)
41	T3139A	Intermediate Wire Rack (Option 46 & 48)
42	D1162U	Wire Rack Support Assy, Left (Option)
43	D1163U	Wire Rack Support Assy, Right (Option)
44	M1335A	Audio Alarm (Discontinued)
45	D2069X	Stacking Kit

Note: When ordering, always specify Part#, Model#, Serial# and Voltage/Phase.

EXPLODED VIEWS & PARTS LISTS

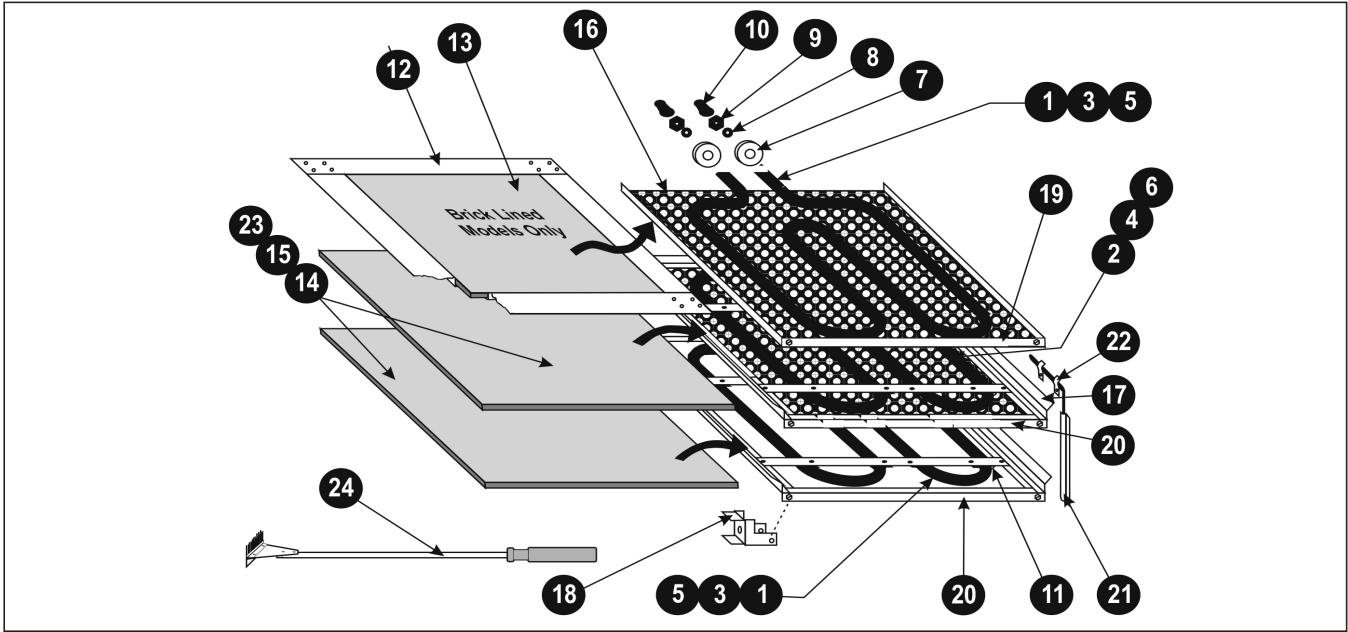

P-44S, P-44BL, P-46S, P-48S Interior Components & Accessories

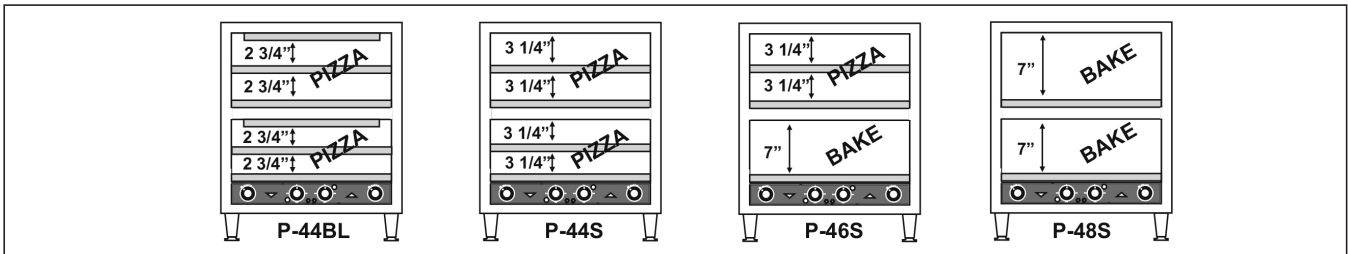

Deck Arrangement by Model

Item	P/N	Description
1	L1072X	Element, 208V/1075W, Top & Bottom
2	L1071X	Element, 208V/1450W, Center
3	L1035X	Element, 230V/1075W, Top & Bottom
4	L1034X	Element, 230V/1450W, Center
5	L1117X	Element, 200V/1075W, Top & Bottom (Japan)
6	L1116X	Element, 200V/1450W, Center (Japan)
7	P1019A	Porcelain Spacer
8	Q3016A	Washer, Star, #6
9	Q1002A	Nut, 6-32
10	S1061X	Terminal Cap, 6-32
11	K1355X	Element Clip
12	D1158U	Ceramic Top Frame Assy (P-44BL Only)

Item	P/N	Description
13	T1120Y	Deck, ea. 17 3/4 x 17 1/2 x 1/2 (P-44BL only)
14	T1121Y	Deck, 20 13/16 x 20 13/16 x 1/2 (each)
15	T1121X	Deck, 20 13/16 x 20 13/16 x 1/2 (set/2)
16	D4040X	Fresh Dough Baffle
17	D1152T	Hearth Frame Assy (No Element)
18	D4039K	Deck Support
19	D4031X	Baffle Trim
20	D1142K	Hearth Trim
21	D1134K	Capillary Cover
22	Q4021X	Clip, 3/16"
23	T1222K	Steel Bake Deck (Optional)
24	T5107Y	Deck Scraper Brush

Note: When ordering, always specify Part#, Model#, Serial# and Voltage/Phase.

EXPLODED VIEWS & PARTS LISTS

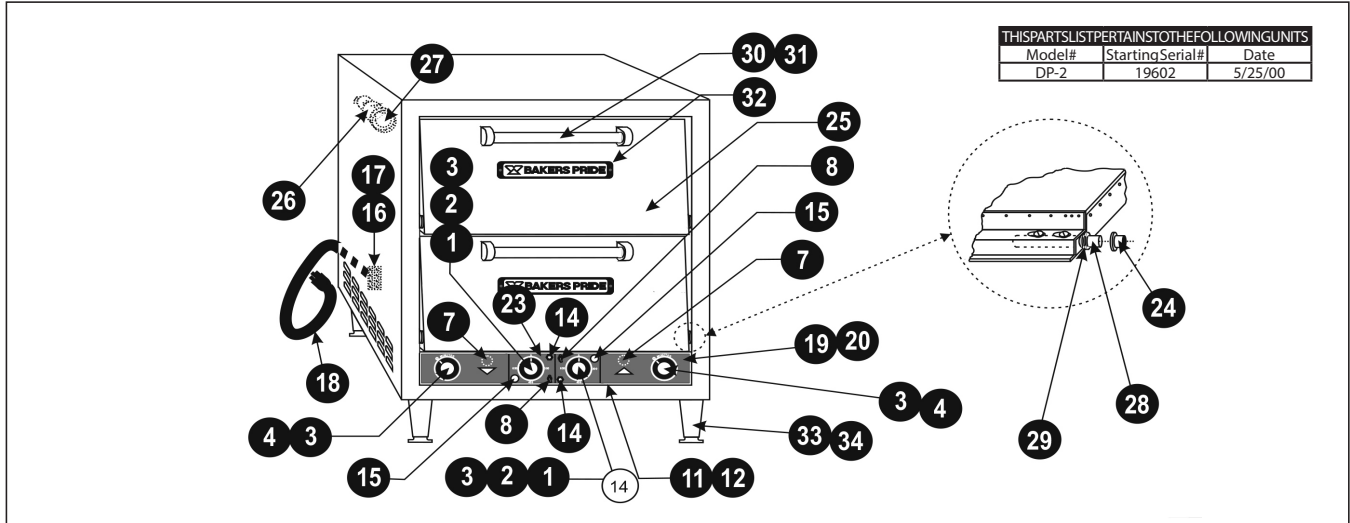

DP-2 Exterior / Door / Controls (Electro-Mechanical Timers)

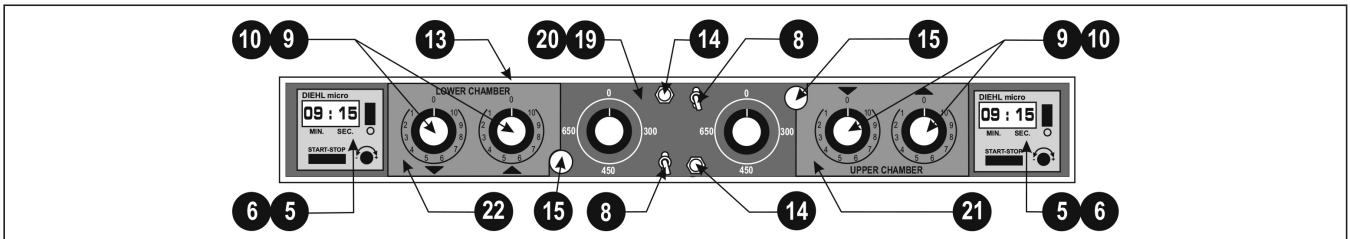

Control Panel with Digital Timers & Infinite Switches (Optional)

Item	P/N	Description
1	M1098X	Thermostat w/Knob, EGO
2	M1192X	T-stat w/Knob, CE "430C" (High Heat)
3	S1311X	Knob (Thermostat & Timer)
4	M1384A	Timer, Elec-Mech, 15 Min (220V)
5	M1275X	Timer, Electronic, 60Hz (Domestic)
6	M1274X	Timer, Electronic, 50Hz (CE)
7	M1335X	Audio Alarm (Discontinued)
8	M1259X	Toggle Switch (Lights, On/Off)
9	M1367A	Infinite Switch, 208V
	M1368A	Infinite Switch, 240V
10	S1205X	Knob, Infinite Switch
11	D2101U	Control Panel (Rot-Elec Timer)
12	D4046U	Control Panel (Rot-Elec Timer/Infinite Sw.)
13	D4045U	Control Panel (Electronic Timer/Infinite Sw.)
14	M1330A	Circuit Breaker, 3A
15	P1127X	Pilot Light, Amber
16	P1003X	Terminal Block, 3 Pole (Domestic)
17	P1004X	Terminal Block, 4 Pole (CE)

Item	P/N	Description
18	P6385A	Line Cord, 250V/30A
19	U1304A	Control Panel Overlay
20	U1310A	Control Panel Overlay (High-Heat)
21	U1289A	Overlay, Top Infinite Controls
22	U1288A	Overlay, Bottom Infinite Controls
23	U1297A	18 Minute Timer Overlay (50 cycles)
24	S3019X	Door Bushing
25	D4006X	Door Assembly
26	P1145X	Light Fixture (w/240V, 15W Bulb)
27	P1147X	Light Bulb, 240V/15W
28	S3001X	Door Rod
29	Q3021X	Door Rod Spacer Kit (1 Kit per Door)
30	S1316U	Door Handle
31	Q2041A	Screws, 1/4-20 x 1/2 RH (Door Handle)
32	U1044X	Bakers Pride Nameplate, 8"
33	S1014Y	4" Adjustable Leg (each)
34	S1014X	4" Adjustable Leg (Set/4)
N/S	D2069X	Stacking Kit

Note: When ordering, always specify Part#, Model#, Serial# and Voltage/Phase.

EXPLODED VIEWS & PARTS LISTS

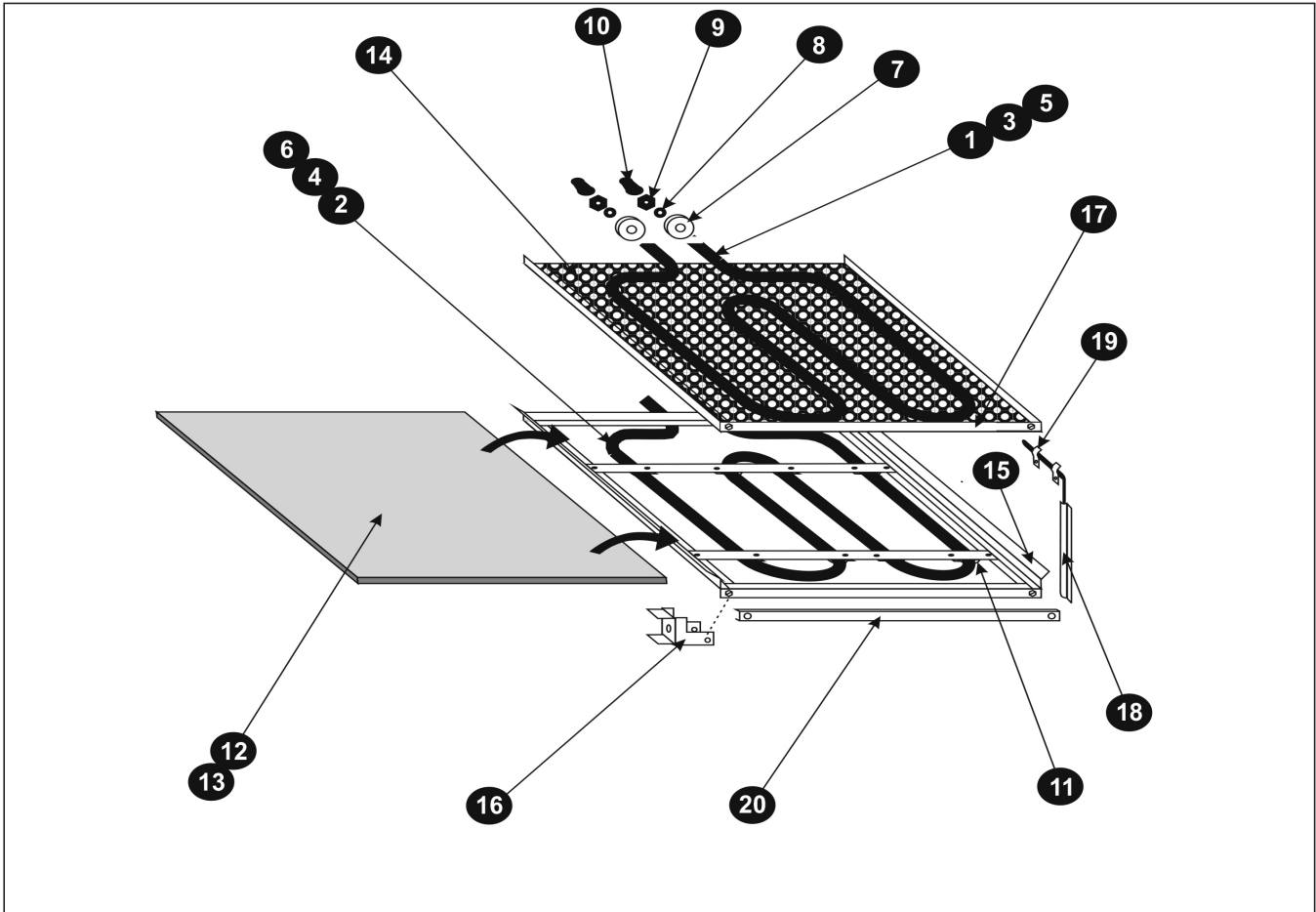

DP-2 Interior Components

Item	P/N	Description
1	L1072X	Element, 208V/1075W, Top
2	L1071X	Element, 208V/1450W, Bottom
3	L1034X	Element, 230V/1075W, Top
4	L1035X	Element, 230V/1450W, Bottom
5	L1117X	Element, 200V/1075W, Top (Japan)
6	L1116X	Element, 200V/1450W, Bottom (Japan)
7	P1019X	Porcelain Spacer
8	Q3016A	Washer, Star, #6
9	Q1002A	Nut, 6-32
10	S1061X	Terminal Cap, 6-32

Item	P/N	Description
11	K1355X	Element Clip
12	T1121Y	Hearth Deck 20 13/16 x 20 13/16 x 1/2 (each)
13	T1121X	Hearth Deck 20 13/16 x 20 13/16 x 1/2 (Set/2)
14	D4040X	Fresh Dough Baffle
15	D1152T	Hearth Frame Assy
16	D4039K	Deck Support
17	D4031K	Baffle Trim
18	D4034K	Capillary Cover
19	Q4021X	Clip, 3/16" (Capillary)
20	D1142K	Deck Trim

Note: When ordering, always specify Part#, Model#, Serial# and Voltage/Phase.

LIMITED EQUIPMENT WARRANTY

Baker's Pride warrants to the original purchaser of new Baker's Pride products to be free from defects in material or workmanship, under normal and proper use and maintenance service as specified by Baker's Pride and upon proper installation and start-up in accordance with the instructions supplied with each Baker's Pride unit. Baker's Pride obligation under this warranty is limited to a period of one [1] year from the date of original installation, or eighteen [18] months from original invoice date, whichever occurs first. Defects that occur as a result of normal use, within the time period and limitations defined in this warranty, will at Baker's Pride discretion have the parts replaced or repaired by Baker's Pride or a Baker's Pride-authorized service agency.

THIS WARRANTY IS SUBJECT TO ALL LISTED CONDITIONS

Repairs performed under this warranty are to be performed by an Baker's Pride authorized service agency. Baker's Pride will not be responsible for charges incurred or service performed by non-authorized repair agencies. In all cases, the nearest Baker's Pride-authorized service agency must be used. Baker's Pride will be responsible for normal labor charges incurred in the repair or replacement of a warranted product within 50 miles (80.5 km) of an authorized service agency. Time and expense charges for anything beyond that distance will be the responsibility of the owner. All labor will need to be performed during regular service hours. Any overtime premium will be charged to the owner. For all shipments outside the U.S.A. and Canada, please see the International Warranty for specific details. It is the responsibility of the owner to inspect and report any shipping damage claims, hidden or otherwise, promptly following delivery. No mileage or travel charges will be honored on any equipment that is deemed portable. In general, equipment with a cord and plug weighing less than 50 lb. (22.7 kg) is considered portable and should be taken or shipped to the closest authorized service agency, transportation prepaid.

CONTACT

Should you require any assistance regarding the operation or maintenance of any Baker's Pride Manufacturing; phone or email our service department. In all correspondence provide the model number and serial number of the unit needing service; include the voltage or gas type.

Normal Business Hours: 8:00 a.m. to 4:30 p.m. Central

Telephone: 800-264-7827 Tech Service Option 2

Email: TechService@partstown.com

www.bakerspride.com

WARRANTY EXCLUSIONS

THE FOLLOWING WILL NOT BE COVERED UNDER WARRANTY.

Baker's Pride sole obligation under this warranty is limited to either repair or replacement parts, subject to the additional limitations detailed below. This warranty neither assumes nor authorizes any person to assume obligations other than those expressly covered by this warranty.

- Any product which has not been used, maintained, or installed in accordance with the directions published in the appropriate installation sheet and/or owner's manual, including incorrect gas or electrical connection. Baker's Pride is not liable for any unit which has been mishandled, abused, misapplied, subjected to harsh chemicals, modified by unauthorized personnel, damaged by flood, fire, or other acts of nature [or God], or which have an altered or missing serial number.
- Installation, labor, and job checkouts, calibration of heat controls, air and gas burner/bypass/pilot adjustments, gas or electrical system checks, voltage and phase conversions, cleaning of equipment, or seasoning of griddle surface.
- Replacement of fuses or resetting of circuit breakers, safety controls, or reset buttons.
- Replacement of broken or damaged glass components, quartz heating elements, and light bulbs.
- Labor charges for all removable and consumable parts in gas charbroilers and hotplates, including but not limited to burners, grates, and radiants.
- Any labor charges incurred by delays, waiting time, or operating restrictions that hinder a service technician's ability to perform service.
- Replacement of parts that fail or are damaged due to normal wear or labor for replacement of parts that can be replaced during a daily cleaning routine, such as but not limited to silicone belts, PTFE non-stick sheets, control labels, knobs, bulbs, fuses, quartz heating elements, baskets, racks, and grease drawers.
- Any economic loss of business or profits.
- Non-OEM parts. Use of non-OEM parts without Baker's Pride approval will void the warranty.
- Units exceeding one [1] year from original installation date, or more than eighteen [18] months from original invoice date, whichever comes first.

ADDITIONAL WARRANTIES

- Specific/chain-specific equipment may have additional and/or extended warranties.

The foregoing warranty is in lieu of any and all other warranties expressed or implied and constitutes the entire warranty.



265 Hobson St. • Smithville, TN 37166
Phone 800.527.2100 | bakerspride.com

Be sure to keep up with new product
announcements and events on social media!

