

**BLODGETT
COMBI**

Electric Boilerless Combi with
Touchscreen Control & Hoodini Ventless Hood

BLCT-102E-H

The BLCT-102E-H offers an ideal meal capacity of 125-300 meals.

Cook the way you want - the Blodgett Combi touchscreen control lets you choose which kind of chef you want to be. You can cook manually and easily fine-tune your settings. Use pre-programmed recipes to ensure consistent results every time. Or use the SmartChef feature which automatically selects the optimum settings for an effortless cooking process.

Hoodini is the ultimate in ventless hood technology. The Hoodini™ hood, designed for the Blodgett Combi, lets you place your oven just about anywhere. The Hoodini removes smoke, odor, and moisture from the oven cavity. Oven fry bacon or roast chickens and breathe easy. Plus you save valuable floor space under the hood.



Shown on optional stand w/ casters

HOODINI^{***}



CAPACITY

- ❑ Standard pan cassette with 3.35" (85mm) spacing holds eight full size sheet pans or sixteen 12" x 20" x 2-1/2" deep North American hotel pans
- ❑ Optional pan cassette with 2.56" (65mm) spacing holds ten full size sheet pans or twenty 12" x 20" x 2" deep Gastronorm pans

STANDARD FEATURES

- Cassette support platform
 - External detachable core temperature probe with multiple measuring points. User friendly location reduces strain on the probe
 - 21-1/2" tall stainless steel stand with runners & adjustable feet
 - Bright halogen lights for superior visibility
 - Built in external hand shower
 - Removeable cleaning chemical bottle shelf
 - 8 wire shelves
 - Left door hinge, field reversible with purchase of kit
 - Start-up inspection service by factory authorized service agent.
 - One year parts and labor oven warranty*
- * For all international markets, contact your local distributor.

www.blodgett-combi.com

42 Allen Martin Drive, Essex Junction, VT 05452 • Phone: (802) 658-6600 • Fax: (802) 864-0183

P/N 62689 Rev F (3/21)

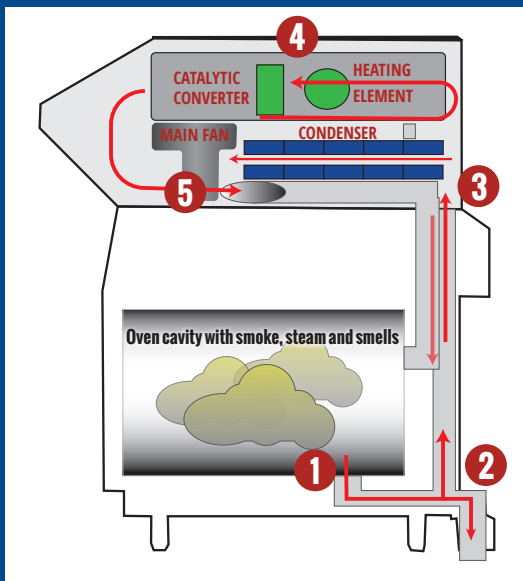

HOODINI VENTILATION SYSTEM

- Hoodini ventless hood combines catalytic system with condensing system. The condenser removes steam exhaust while the catalyst removes smoke and fumes.
- No filters to change
- Integrated hood - no fire suppression required
- Top clearance required = Zero inches!
- Not for use with FlavorSmoke 450 smoker box
- UL (KNLZ) listed for ventless operation
- Using EPA test method 202, emissions of grease laden vapors were measured at 0.35 mg/m³ for raw, bone-in, skin-on, halved roasting chickens, and 0.40 mg/m³ for raw bacon on the BLCT-62E-H model. Based on this data, theoretical values were established by U.L. for models: BLCT-61E-H, BLCT-101E-H, and BLCT-102E-H. All models' results are less than the established 5 mg/m³ standard.

OPTIONS & ACCESSORIES

(AT ADDITIONAL CHARGE)

- **Banqueting Accessories**
 - Pan cassette w/ 2.56" (65mm) spacing
 - Pan cassette w/ 3.35" (85mm) spacing
 - 63 plate cassette w/ 2.56" (65mm) spacing
 - 51 plate cassette w/ 3.35" (85mm) spacing
 - Transport trolley, to move the cassette
 - Insulated thermal blanket w/vent
- **Legs and Stands**
 - 21-1/2" tall stainless steel stand with runners & casters
 - Adjustable feet for table top installation
- Extra wire oven racks
- Right hinge door
- Backflow preventer
- Extra year warranty

(AT NO ADDITIONAL CHARGE)

- Optional pan cassette w/ 2.56" (65mm) spacing & 10 wire shelves in lieu of standard pan cassette & shelves

OVEN OPERATION

- Injection steam system - water is injected onto the heating elements, the resulting steam is distributed in the oven chamber by the fan wheel.
- Easy to use touchscreen control stores up to 500 recipes with up to 15 steps each
- Multiple cooking modes include hot air, CombiSmart, retherm, steaming, low-temperature steaming, forced steaming, proofing, preheating
- CombiOptima automatically measures and controls the humidity level in the oven
- SmartChef automatic cooking provides presets for grilling, steaming, braising, browning and breaded products. Select your desired cooking result from rare to well done, and your surface appearance from light to dark.
- Manual or automatic cooling
- Automatic humidity pulsing
- Timed steam injection or instant steam on demand at any point in the cook cycle
- Rack timing for setting individual timers for each rack
- Advanced rack timing for timing multiple recipes of the same group simultaneously on separate racks
- Reversible 9 speed fan for optimum baking and roasting results
- Programmable vent release allows for automatic venting if desired
- USB port for data and recipe transfer
- HACCP recording and documentation
- Automated CombiWash system features very low water and detergent consumption and no contact with chemicals. No proprietary chemicals required, see owner's manual for detergent guidelines.



CONSTRUCTION

- 304 stainless steel exterior and interior
- Dual pane tempered viewing window with hinged inner glass for easy cleaning
- 2" (50mm) fixed drain in the bottom center of cavity
- Door mounted drip tray reduces the risk of wet floors
- Separate water lines, for cooking and quench
- Automatic door stops in positions 110° and 180°
- Left hinge door is field convertible to the right side (with the purchase of conversion kit)
- Two step safety door latch. The first step stops the fan.

SHORT FORM SPECIFICATIONS: Provide Blodgett Combi model BLCT-102E-H combination-oven/steamer with ventless hood. The BLCT-102E-H has a pan cassette with 3.35" (85mm) spacing that holds eight full size sheet pans or sixteen 12" x 20" x 2-1/2" deep North American hotel pans. The optional pan cassette with 2.5" (65mm) spacing holds ten full size sheet pans or twenty 12" x 20" x 2" deep Gastronorm pans.

Unit has a 304 stainless steel exterior and interior. Oven door has a dual pane tempered viewing window with hinged inner glass for easy cleaning. Includes a built in external hand shower and separate water lines. Unit shall have bright halogen lights for superior visibility and an external detachable core temperature probe. Oven has two separate water lines for cooking and quench. You may choose to cook with pressureless steam, hot air, or combination of steam and hot air.

The Hoodini integrated hood requires no fire suppression or filter.

The touchscreen control stores 500 recipes with 15 stages each, in addition to pre-programmed recipes. Multiple modes include hot air, combi, retherming, steaming, low-temperature steaming, forced steaming, proofing, cooling, and preheating. CombiOptima automatically measures and controls the humidity level in the oven. The control allows for timed steam injection or instant steam on demand at any point in the cook cycle. Rack timing provides individual timers for each rack. Advanced rack timing allows for timing multiple recipes of the same group simultaneously on separate racks of the oven. Use SmartChef automatic cooking presets for grilling, steaming, braising, browning and breaded products. HACCP quality control, USB connectivity and automatic service diagnosis are included. Programmable vent release allows for automatic venting if desired. The reversible 9 speed fan provides optimum baking and roasting results. The automated combi wash system features very low water and detergent consumption and no contact with chemicals.

Includes one-year parts and labor warranty. Provide start-up inspection service by a factory authorized service agent. Provide options and accessories as indicated.

NOTE: The company reserves the right to make substitutions of components without prior notice.

POWER SUPPLY

VOLTAGE	KW	PHASE	AMPERAGE
HOOD - dedicated circuit			
120VAC	-	1 Ph	15 amp max.
OVEN			
208 VAC	27	3 Ph	75 amp
240 VAC	27	3 Ph	65 amp
480 VAC	27	3 Ph	33 amp

Other voltage available, contact factory.

This appliance uses a variable frequency drive, which can be known to product high frequency electrical noise. In some cases units must be hard wired. This avoids false positives on ground fault devices susceptible to errors from electrical noise. All installations must comply with local and national codes.

WATER SUPPLY

Good quality water feed is the responsibility of the owner. Water quality must be within the following general guidelines.

TDS: 40-125 ppm	pH: 7.0-8.5
Hardness: 35-180 ppm	Silica: <13 ppm
Chloramine: <0.2 ppm	Chlorine: <0.2 ppm
Chlorides: <25 ppm	

The best defense against poor water quality is a water treatment system designed to meet your water quality conditions. Blodgett offers optional water treatment systems.

Pressure

- 40 (min)-50 (max) PSI

Connections

- 2" drain connection - max. drain temperature 140°F (60°C)
- 3/4" garden hose cold water

DRAIN





The drain piping must consist of temperature resistant material, greater than 160°F, and be of adequate diameter not to cause flow restriction. Improper materials may deform and cause restrictions, thus affecting performance.

Appliance is to be installed with backflow protection in accordance with federal, state or local codes.



DIMENSIONS ARE IN INCHES (MM)

LEGEND

-  FILTERED WATER
-  UNFILTERED WATER
-  DRAIN
-  ELECTRICAL
-  VENT

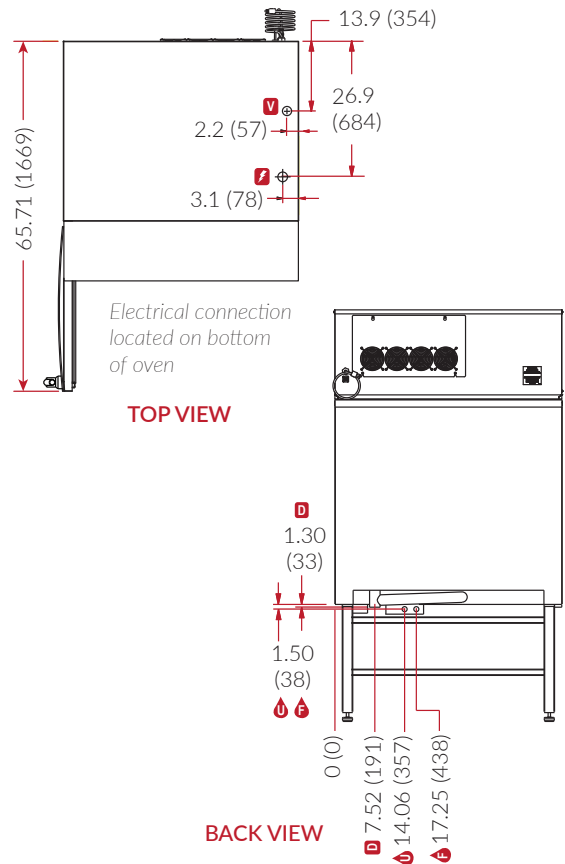
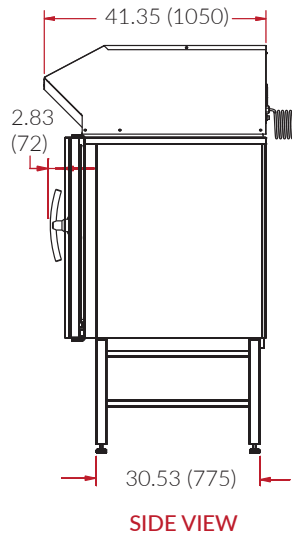
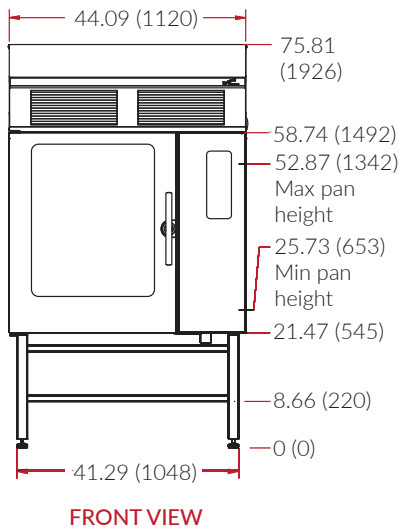

SHIPPING

WEIGHT

675 lbs (306 kg)

CRATE SIZE

Oven w/hood	61" H x 54" W x 49" D (1549 mm x 1371 mm x 1245 mm)
Stand	36" H x 42" W x 35" D (914 mm x 1067 mm x 889 mm)

DIMENSIONS & CLEARANCES

FLOOR SPACE

44.21" x 37.44" (1122 x 951mm)

UNIT HEIGHT

On standard stand	75.81" (1926mm)
Table model	54.34" (1380mm)

MINIMUM ENTRY CLEARANCES (per section)

Uncrated	41.35" (1050mm)
Crated	49" (1245mm)

OVEN INSTALLATION CLEARANCE REQUIREMENTS

Kitchen Environment	Low temp.	High temp.*
Left Side & Back	2" (50mm)	2" (50mm)
Right (control) Side	2.8" (70mm)	16" (400mm)

* includes heat sources (fryers, hot plates, etc) placed on the control side of the combi

For servicing, Blodgett recommends maintaining at least 16" (400 mm) between the control side and walls or non moveable equipment.

