



# SHEET PAN DISPENSERS

## Mobile Dispenser Carts for 18"x26" Pans

### Open and Enclosed Styles

# SPECIFICATIONS

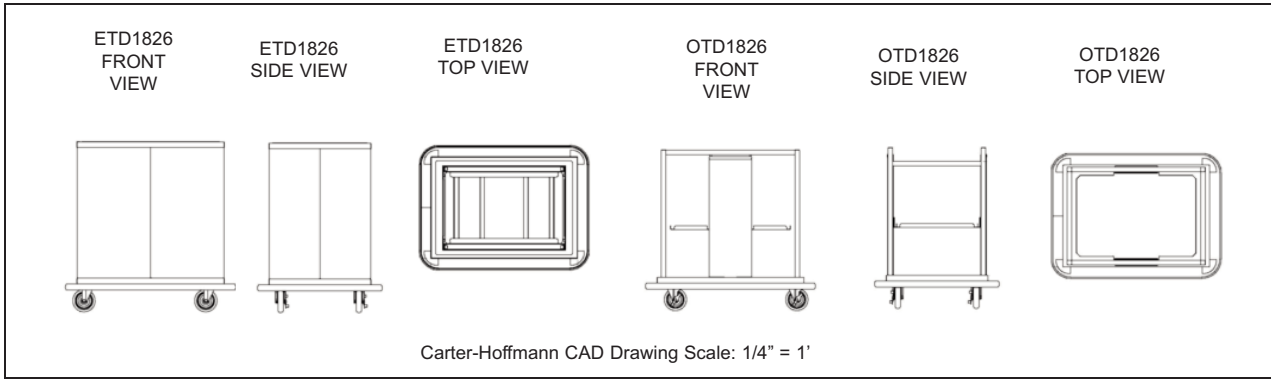

Model Number	Pan Size		Description	Overall Dimensions			Caster Diameter		Shipping Weight	
	in	mm		Height in mm	Depth in mm	Width in mm	in	mm	lbs	kg
<input type="checkbox"/> ETD1826	18 x 26	457 x 660	Enclosed single stack	38 <sup>1</sup> / <sub>8</sub>	968	23 584	33 838	5 127	170	77
<input type="checkbox"/> OTD1826	18 x 26	457 x 660	Open single stack	36 <sup>1</sup> / <sub>4</sub>	921	23 584	33 838	5 127	132	62

**CONSTRUCTION: ENCLOSED DISPENSERS...** Completely welded cabinet construction with outer cabinet formed and welded to base. Built-in stainless tray platform. All stainless steel construction with polished exterior.

**CONSTRUCTION: OPEN DISPENSERS...** High strength stainless steel tubular frame with solid stainless steel bottom and tray platform.

**BASE FRAME...** 12 gauge stainless steel full depth caster bolsters with 1" x 1" 14 gauge stainless steel channels welded to bolsters.

**CASTERS...** 5" diameter, all swivel ball bearing type casters, plate mounted and bolted to frame. Two casters fitted with brakes. Wheel-ahead caster pattern.

**STYLING...** All stainless steel with red custom colored matching casters and bumper vinyl.

**DISPENSER PLATFORM...** Field adjustable springs to accommodate differences in tray weights and heights. Number of connected springs can be increased or decreased to change the platform tension release tension in 2.5 oz/in. Disconnected springs remain in place and out of the way. All stainless steel platform.

**CAPACITY...** ETD1826: approximately 60 18"x26" trays. OTD1826: approximately 50 18"x26" trays.

- OPTIONS AND ACCESSORIES...**
- Wrap-around extruded aluminum bumper with non-marking vinyl insert; specify red or grey
  - Four soft durometer cushioned corner bumpers

Specifications subject to change through product improvement & innovation.



**CARTER-HOFFMANN**  
 1551 McCormick Ave., Mundelein, IL 60060  
 (847) 362-5500 • (800) 323-9793 • Fax (847) 367-8981  
[www.carter-hoffmann.com](http://www.carter-hoffmann.com)

## SHEET PAN DISPENSERS

*Since 1947, foodservice equipment that delivers!*



**ETD1826**

(shown with optional wrap-around bumper)

**ETD: COMPLETELY WELDED TURNED-IN SEAM CONSTRUCTION...** All stainless steel construction. Adds rigidity to entire cabinet for maximum durability and reliable performance, and eliminates raw edges for easy cleaning and safety. Sleek exterior styling is easy to clean.



**OTD1826**

(shown with optional wrap-around bumper)

**OTD: ALL STAINLESS STEEL TUBULAR FRAME...** Heavy-duty stainless steel frame with stainless steel bottom and tray platform.

**RUBBER TREAD CASTERS WITH SEALED ROLLER BEARING...** Long lasting, easy rolling for maximum load and minimum maintenance. All swivel casters fitted with brakes.



**ADJUSTABLE TRAY PLATFORM...**Field adjustable springs to accommodate differences in tray weights and heights. Number of connected springs can be increased or decreased to change the platform tension.