



Job: Item No.:

Notes:

Model Number:  PH1200  PH1215  
 PH1225  PH1250

## Heated Transport Carts

## SPECIFICATIONS



PH1250

### FEATURES

- Bottom mounted, removable convection heating system
- Dial thermometer with remote sensing bulb
- Capable of heating to 200°F (93°C); pre-heat to 160°F (71°C) in approximately 25 minutes
- All welded, turned-in seam, stainless steel construction
- High-density 1" thick insulation
- Stainless steel caster bolsters; perimeter tube supports welded to bolsters
- Two heavy-duty aluminum vertical push handles bolted to sides with reinforced back-up plates
- Double panel door with vinyl gasket
- Concealed, stainless steel pin hinge; 270° door swing (except center door on PH1250)
- Sliding latch with finger grip
- High temperature magnetic door gasket
- 5" diameter polyurethane casters; two fitted with brakes
- Offset wheel-ahead caster pattern
- Non-marking gray vinyl bumper set in heavy-duty extruded aluminum frame
- Removable tray racks with channel slides on 2.75" centers
- Accommodates 12"x20" steam table pans

### OPTIONS AND ACCESSORIES

- Menu card holder
  - Stainless steel tubular handles
  - Polycarbonate thermometer cover
  - Transport latch with padlock hasp
  - Locking paddle latch with key
  - Rack & heater hold down devices
  - Tamper-resistant fasteners
  - Stainless steel push handles
  - Alternate electrical configuration
  - Alternate caster sizes and types
  - Removable canned fuel holder
  - Filler plate (no heating unit)
- Lift-up pull handle (n/a: PH1200)
  - Reinforced cord strain relief grip
  - Correctional package

### DESCRIPTION

PH Series Heated Food Transport Cabinets are designed to hold and transport cooked food warm and ready for serving. They are constructed of sanitary stainless steel and feature a bottom-mounted lift-out heating system with dial controls and blower heat for even air flow throughout the cabinet. Transport features include wrap-around bumper, wheel-ahead caster pattern and insulated turned-in seam construction.

### SHORT FORM SPECIFICATIONS

Heated food transport cart, electric, insulated, welded, turned-in seam stainless steel construction with side-mounted push handles and flush-mounted transport latch with finger grip. Lift-out, convection heater. Stainless steel tray racks with channel slides. Standard 2.75" spacing for 12"x20" steam table pans. Non-marking gray vinyl wrap-around bumper. Polyurethane casters set in wheel-ahead caster pattern. 120V, 60Hz, 1Ph. 10', 3 wire rubber cord with 3-prong grounding plug. NEMA 5-15P. PH1200: 1530 watts, 12.8A. PH1215, PH1225 & PH1250: 1650 watts, 13.7A.

### CERTIFICATIONS



### WARRANTY

One-year warranty for parts and labor.



**CARTER-HOFFMANN**  
1551 McCormick Avenue, Mundelein, IL 60060  
847.362.5500 • 800.323.9793  
www.carter-hoffmann.com

Follow us



Form PH1200Series\_0821





Job: Item No.:  
 Notes:  
 Model Number:  PH1200  PH1215  
 PH1225  PH1250

## Heated Transport Carts

## SPECIFICATIONS

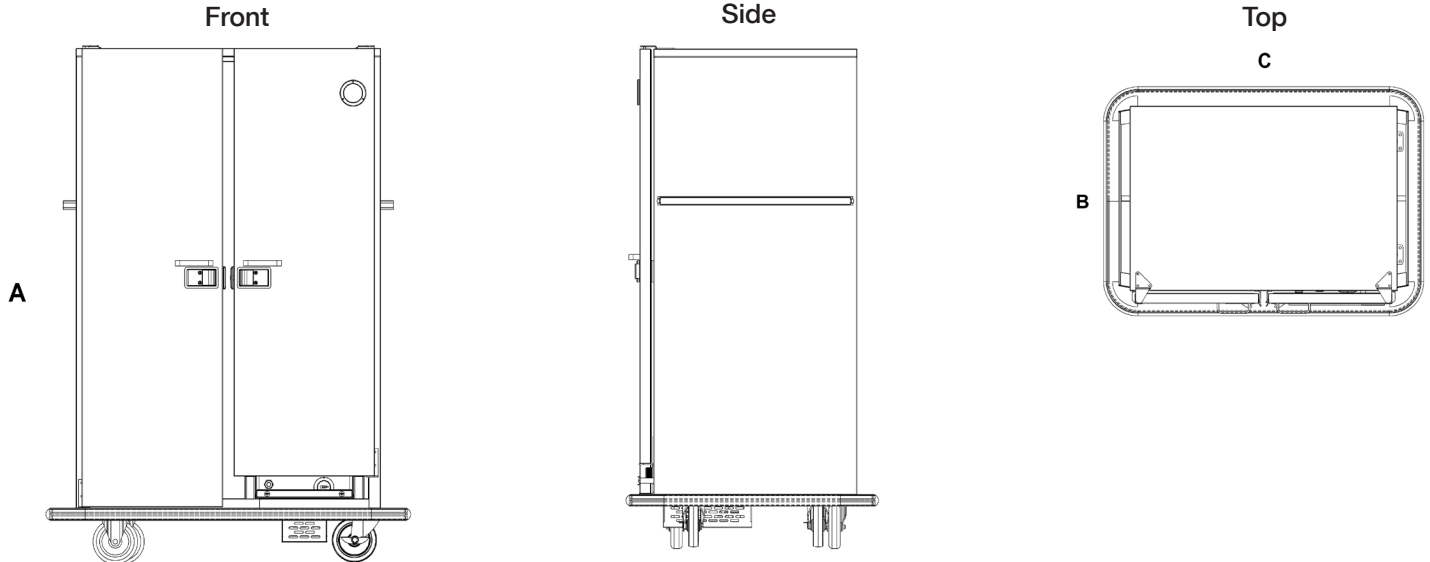

### CLEARANCES

A clearance of at least 2" from any wall or combustible material. A clearance of least 36" at the front of the cabinet is required to open the door. Cabinet must be placed on a solid level floor.

### ELECTRICAL DATA

Single electrical connection.

PH1200: 120 Volts, 1530 Watts, 12.8 Amps, 60Hz, single phase. 10' three wire rubber cord with 3-prong grounding plug. NEMA 5-15P

PH1215, PH1225, PH1250: 120 Volts, 1650 Watts, 13.7 Amps, 60Hz, single phase. 10' three wire rubber cord with 3-prong grounding plug. NEMA 5-15P



Model Number	Pan Capacity*	Inside Working Height		Height [A]		Depth [B]		Width [C]		Caster Diameter		Shipping weight	
	12"x20"	in	mm	in	mm	in	mm	in	mm	in	mm	lbs	kg
PH1200 (single door)	16	46	1168	58	1473	28	711	24	610	5	127	280	127
PH1215 (two doors)	21	30	762	42	1067	28	711	46 <sup>3/4</sup>	1187	5	127	325	147
PH1225 (two doors)	33	46	1168	58	1473	28	711	46 <sup>3/4</sup>	1187	5	127	350	159
PH1250 (three doors)	50	46	1168	58	1473	28	711	65 <sup>1/4</sup>	730	5	127	450	204

\*Pan spacing at 2.75" (89mm). Standard pan depth of 2.5". Cart will accommodate deeper pans, but at reduced capacity. Will also accommodate 12"x10" pans.

Due to periodic changes in designs, methods, procedures, policies and regulations, the specifications contained in this sheet are subject to change without notice. While Carter-Hoffmann exercises good faith efforts to provide information that is accurate, we are not responsible for errors or omissions in information provided or conclusions reached as a result of using these specifications. By using the information provided, the user assumes all risks in connection with such use.