



TILT-ASPIRAL MIXER



Spiral Mixer, 350 Lb. Dough Capacity, 2 Speeds, Programmable Digital Control, Stationary Stainless Steel Bowl, Safety Guard & Dough Hook, Cast Iron Frame with Enamel Coated Steel Finish, 2 HP Hydraulic Lift, Protective Rail Dropping at 55 3/4", 2 HP Bowl & 10 HP Hook, 208-240V/60/3P/32A, NEMA 15-50P



PROJECT _____
 ITEM NO. _____
 NOTES _____
 MODEL NUMBER: **AB100XA , AB100XE , AB100XB**



FEATURES

- Unique Easy to Use Digital Control
 - 2 Speeds (no need to stop mixer to change speed)
 - 99 Minute Mixing Timer
 - 9 Programmable Speed & Time Settings
- Emergency Stop
- Hydraulic Lifting System to Empty Bowl
- Stainless Steel 264 Quart Bowl with Rounded Center Post
- Stainless Steel Dough Hook
- Integrated Standard Bowl Drain
- Wire Guard for Bowl Featuring Automatic Motor Cut-Off Switch
- Thermal Overload Protection for Motor
- Non-Slipping Belt Driven Motor
- Jog & Reverse

CONSTRUCTION

- Heavy Duty Frame with Lead-Free Enamel Coating

OPTIONS & ACCESSORIES

- Stainless Steel Construction [Suffix I]
- Paddle w/Scrapper (Installed by Factory)
- Left Lifting Model (Replace X with C)
- Right Lifting Model (Replace X with D)
- #12 Attachment Hub
- International Voltages Available (Contact Factory)
- Touchscreen Controls
- Integrated Water Meter

CLEARANCES

- 6" (152mm) On Left & Right Side
- 25" (635mm) Back
- Top & Bottom Must Remain Unobstructed

WARRANTY

- One Year Labor & Two Year Parts



NEMA 15-50P



Model	Weight	Overall Dimensions					Bowl	Hook	Hydraulics
		W	D	Height Min.	Height Max.	Dropping Height			
AB100XA	2976 (1350)	64.56" (1640)	77.75" (1975)	61.41" (1560)	98.03" (2490)	56.69" (1440)	3 HP	12 HP	2 HP
AB100XB	3291 (1493)	64.56" (1640)	77.75" (1975)	61.41" (1560)	112.20" (2850)	74.01" (1880)	3 HP	12 HP	2 HP





PROJECT _____
 ITEM NO. _____
 NOTES _____
 MODEL NUMBER: **AB100XA , AB100XE , AB100XB**

DRAWINGS

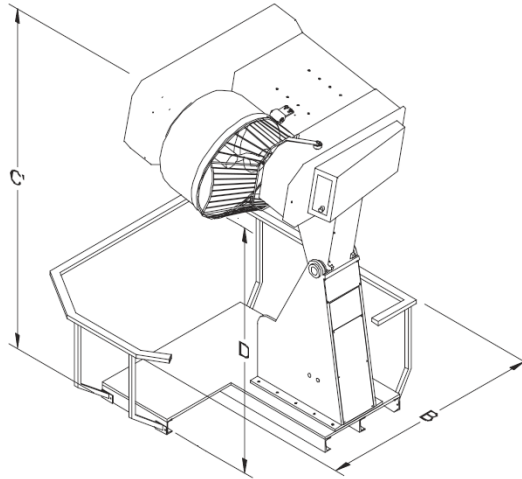
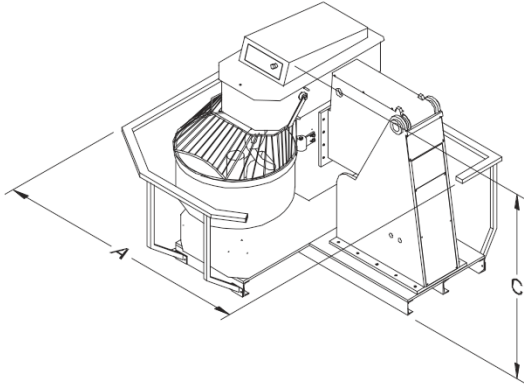

- A - 79 5/8"
- B - 72 7/8"
- C - 60 1/2"
- C - 101 5/8"
- D - 63 5/8"

Model	Electrical System				
	Volts	Amps	Phase	Hz	NEMA
AB100XA	208	32	3	50-60	15-50P
	240				
AB100XE	208	32	3	50-60	15-50P
	240				
AB100XB	208	32	3	50-60	15-50P
	240				

Capacity Chart

Recipe/Product	Pounds	Kilograms
Flour Capacity Minimum	11	5
Flour Capacity Maximum	220	100
50% AR Dough Minimum	17.64	8
50% AR Dough Maximum	253	115
55% AR Dough Minimum	17.64	8
55% AR Dough Maximum	308	140
60% AR Dough Minimum	17.64	8
60% AR Dough Maximum	352.74	160
65% AR Dough Minimum	17.64	8
65% AR Dough Maximum	352.74	160

Calculating AR%

To know the absorption ratio of your recipe use the following formula:

$$\%AR = \text{Water Weight (lbs)} / \text{Flour Weight (lbs)}$$

1 Canadian Gallon of Water = 10lbs (4.54 kg)

1 US Gallon of Water = 8.33lbs (3.77kg)

Use of ice requires a 10% reduction in batch size.
 Drop 10% from the above chart for high gluten flour.

Make sure to take into consideration all water content. This should include any extracts, butter/shortening, eggs, etc. into factoring AR%.

For Example: Your using 1 US Gallon of water and 15lbs of flour = 0.55 or 55% AR

That means you will have a finished product of 23.3lbs of dough at 55% AR. Refer to this chart to find the model you will need.

Doyon/NU-VU recommends the following capacity ratings on based AR%. If dough has a lower AR% we recommend decreasing the recipe to adjust for denser dough. Failure to follow said guidelines or recommendations could result in non-warranted service issues with mixer.

Please contact factory to verify if mixer is suitable for your application.

Note - Different Types of flour have different gluten content and are not universal between products.

Note - Eggs, Milk, Extracts, must be added to liquid when calculating AR%

Due to periodic changes in designs, methods, procedures, policies and regulations, the specifications contained in this sheet are subject to change without notice. While Doyon exercises good faith efforts to provide information that is accurate, we are not responsible for errors or omissions in information provided or conclusions reached as a result of using these specifications. By using the information provided, the user assumes all risks in connection with such use.

