



DOUGH MOULDER



Automatic Dough Moulder, 3 Roller Infeed, Stainless Steel Construction, Hopper Safety System, Synthetic Belt, Retractable Outfeed Table, 1 1/2 HP, Production Up to 2500 Pieces/Hour



PROJECT _____
 ITEM NO. _____
 NOTES _____

MODEL NUMBER: **DM800**



FEATURES

- Automatically Molds Dough Pieces into Elongated Shapes with Tapered Ends
- 3 Roller Infeed
- Delicate, Accurate and Progressive Molding Action
- Hopper Safety System
- Retractable Outfeed Table
- Equipment Stand
- Able to Mold up to 1,200 Pieces per Hour (dependent on operator and workflow)
- Ideal for Doughs with Hydration Between 45-70%
- Adjustable Lengths and Thickness

CONSTRUCTION

- Stainless Steel Construction
- Synthetic Belts
-

WARRANTY

- One Year Labor & Two Year Parts

Model	Weight	Overall Dimensions			Maximum Capacity	Portion Weight	
		W	D	H		Min.	Max.
DM800	550 (250)	37 13/16" (960)	30 1/8" (765)	25 9/16" (649)	30" loaf (762)	1.75 (50)	42.4 (1200)

Model	Electrical System				
	Volts	Amps	Phases	NEMA	Motor
D20	208-240	3	3	L15-20	1 1/2 HP

NEMA L15-20

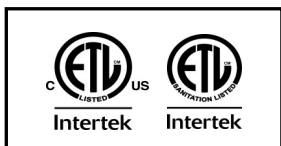
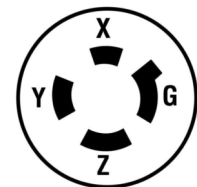

SPECIFICATIONS SUBJECT TO CHANGE WITHOUT NOTICE

KCL & REVIT DRAWINGS UPON REQUEST

REVISION B | 5/27/2021

Follow Us



Doyon

5600 13th Street, Menominee, MI 49858

906.863.4401 | 800.338.9886 | www.doyon.qc.ca





PROJECT _____
 ITEM NO. _____
 NOTES _____

MODEL NUMBER: **DM800**

DRAWINGS

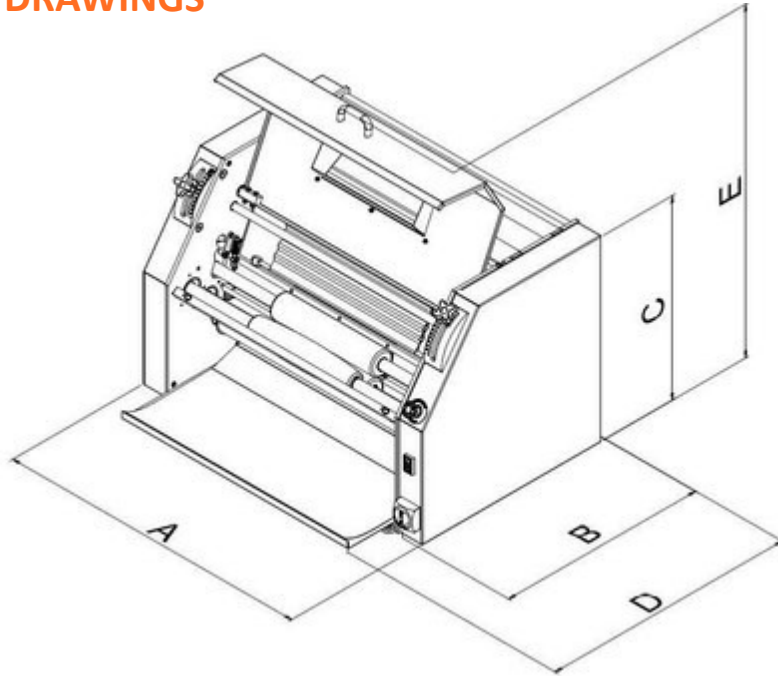

- A - 37 13/16" (960 mm)
- B - 26" (660 mm)
- C - 25 9/16" (650 mm)
- D - 32 7/8" (835 mm)
- E - 37 5/8" (956 mm)

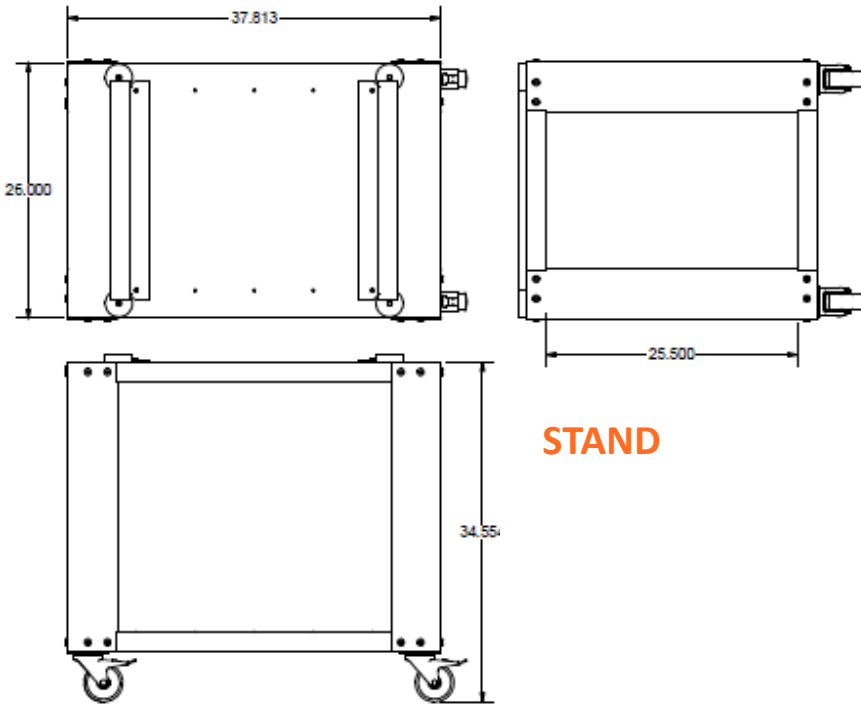

Due to periodic changes in designs, methods, procedures, policies and regulations, the specifications contained in this sheet are subject to change without notice. While Doyon exercises good faith efforts to provide information that is accurate, we are not responsible for errors or omissions in information provided or conclusions reached as a result of using these specifications. By using the information provided, the user assumes all risks in connection with such use.

