

## SINGLE BASIN - MULTICOOKER

### 242 LITERS - 31KW

□ UCPMDE164

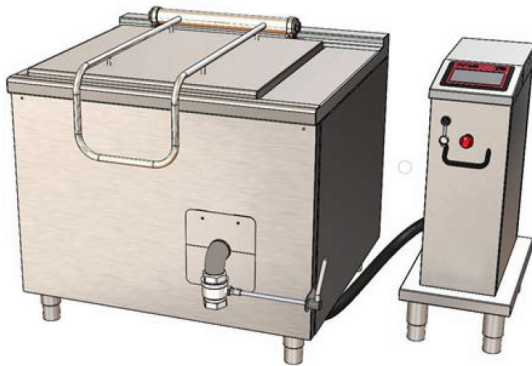

#### General Functional Features

- Heating by means of aluminum casted elements directly in contact with the vessel bottom, controlled by electronic board with automatic activation of minimum 2 °C before the SETPOINT and interruption of heating in case of minimum water level. Baskets lifting and tilting automatically (even with closed lid) stopping in dripping position and removable for cleaning operations. Automatic filling and refilling of water in the vat. Overflow device and system to make starch skimming easier. Front drain cock in stainless-steel, 2 inc., with insulating handle. Optional: Removable shower head (cold water) to make cleaning operations easier. Electronic control by means of multifunctional keyboard with Touch Screen 7" and easy and clear messages
- USB connection to download HACCP data, update the software and load cooking programs
- Ability to interrogate the machine using communication protocol MODBUS over RS485 serial interface
- Connection for power economizer

#### Panel Board Functions

- ON/OFF switch
- Resistive 7" touch screen
- Keys for moving basket
- Selection of 2 different cooking modes, with working temperature setting or min./max. heating
- Cooking type and time setting
- Cooking in "Manual" mode
- Cooking in "Program" mode
- Creating and editing cooking programs, setting: type of cooking; cooking parameters (temperature and time), and possibility to insert text messages
- Automatic vat filling with level maintenance
- Function starch skimming
- Delayed cooking setting with date, time, and programming cycle
- Language settings Touch Screen
- Input of different units of measurement (° C/° F; Liters/gallons; etc)

#### Display/Signal

- Display type of cooking, temperature probes used and set temperature
- Heating operating visual alarm
- Time to end of cycle display
- Water level insufficient (heating does not activate)
- Automatic basket lifting (end of cooking) visual alarm with 10 seconds flashing notice on the Touch Screen
- Thermostat intervention safety signaling
- Self-diagnostics

#### Safety System

- Emergency button
- Heating interruption due to insufficient amount of water in vat
- Blocking of heating for overtemperature of the heating elements

### STANDARD CONSTRUCTION SPECIFICATIONS

Cooking vessel in stainless steel AISI 316 (thickness 30/10). Perforated basket in stainless steel AISI 316 (thickness 15/10) with electric tilting  
Balanced lid in stainless steel AISI 304 (thickness 10/10)  
Supporting structure in stainless steel AISI 304 (thickness 20-30/10)

Heat insulation guaranteed by panels in thick glass fibre  
Outer cover in stainless steel AISI 304, fine satin finish (thickness 10/10)  
Adjustable feet in stainless steel AISI 304 to ensure levelling  
Protection level IPX5



Approval Notes: \_\_\_\_\_

\_\_\_\_\_

\* REG. 0,4 ; + 2 "

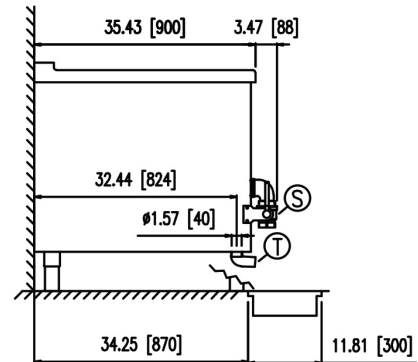
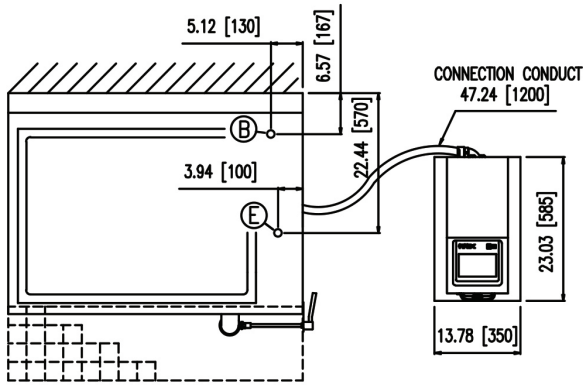
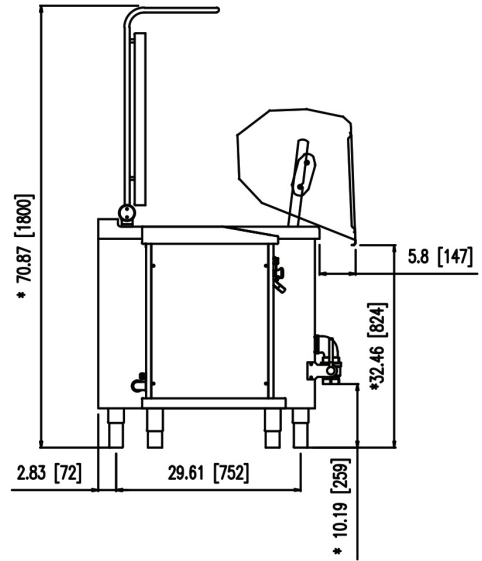
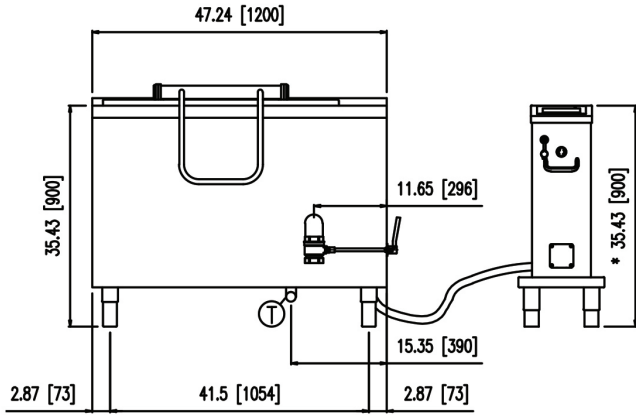

**TECHNICAL SPECIFICATIONS**

DIMENSIONS						Weight	Capacity	Number of Baskets
Width	Depth	Height	Vessel Width	Vessel Depth	Vessel Height			
47.24"	35.43"	35.43"	35.43"	25.20"	16.54"	540 lb	64 gal	1

UTILITIES				
Cold water inlet (B)	Water pressure	STD Voltage (E)	Electric power	Current
1/2"	25-50 PSI	3 PHASE 208V~ 60Hz	23.30 kW	70.0 A
		3 PHASE 220-240 V~ 60Hz	23.30 kW	61.0 A

**INTENDED FOR COMMERCIAL USE ONLY.  
NOT FOR HOUSEHOLD USE.**

