

ELECTRIC TILT BRAISING PAN

38 GALLON

20kW WITH LIFT



UDBRE038CV1

General Functional Features

- Heating by means of armoured elements INCOLOY-800 directly in contact with the steel thermodiffuser plate fixed on the vessel bottom
- Temperature control by system with two probes (product/bottom)
- Automatic baskets lifting system by electric engines controlled by electronic card
- Electronic control by means of multifunctional keyboard with Touch Screen 7" and easy and clear messages
- USB connection to download HACCP data, update the software and load cooking programs
- Ability to interrogate the machine using communication protocol MODBUS over RS485 serial interface
- Connection for power economizer

Panel Board Functions

- ON/OFF switch
- Resistive 7" touch screen
- Keys for moving basin
- Selection of 2 different cooking modes (4 with optional core probe), with working temperature setting
- Core probe (optional)
- Cooking type and time setting
- Set the cooking time using the basket lifters, with possibility to select automatic lowering when the temperature is reached
- Cooking in "Manual" mode
- Cooking in "Program" mode
- Creating and editing multiphase cooking programs, setting for each phase: type of cooking; cooking parameters (temperature and time), and possibility to insert text messages
- Tank water load setting (hot up to 140° F/cold) with automatic liter measurements
- Control for tilting and return of cooking tank from Touch Screen or keyboard
- Delayed cooking setting with date, time, and programming cycle
- Language settings Touch Screen
- Input of different units of measurement (° C/° F; Liters/gallons; etc)

Display/Signal

- Display type of cooking, temperature probes used and set temperature
- Heating operating visual alarm
- Time to end of cycle display
- Audible/visible warning of automatic basket movements
- Display tank out of position for cooking
- Signaling tap position, managing water in the tank
- Signal of lid and cock position during vat tilting
- Thermostat intervention safety signaling
- Self-diagnostics

Safety System

- Emergency button
- Blocking of heating for excess of temperature with manual resettable safety thermostat
- Heating interruption during vat tilting

OPTIONS & ACCESSORIES AT ADDITIONAL COST

- | | | |
|---|---|--|
| <input type="checkbox"/> DAPF0010 - SET FEET | <input type="checkbox"/> D150 - KIT WHEELS | <input type="checkbox"/> DAP01000 - SPATULA FOR OMELETTE |
| <input type="checkbox"/> DSAC0000. - COREPROBE | <input type="checkbox"/> DAF0145 - STRAINER | <input type="checkbox"/> DABF0000 - CONTANIER WITH HOLES |
| <input type="checkbox"/> DADE0010 - CLEANING SHOWER | | |

STANDARD CONSTRUCTION SPECIFICATIONS

Cooking vessel in stainless steel AISI 304 (bottom thickness 15 mm and wall thickness 2,5 mm) with rounded corner angles and anti-overflowing lip. Vessel with electric tilting on front part

Insulated lid with double cover in stainless steel AISI 304 (thickness 12/10), with ergonomic handle, balanced by means of gas springs

Self-supporting frame in stainless steel AISI 304 (thickness 30-40/10)

Outer cover in stainless steel AISI 304, fine satin finish (thickness 12-15/10)
Adjustable feet in stainless steel AISI 304 to ensure levelling, with removable cover for cleaning operations

Fast accessibility to the main functional parts (electronic card, fuses, thermostats...) only removing the frontal panels

Protection level IpX5



Approval Notes: _____

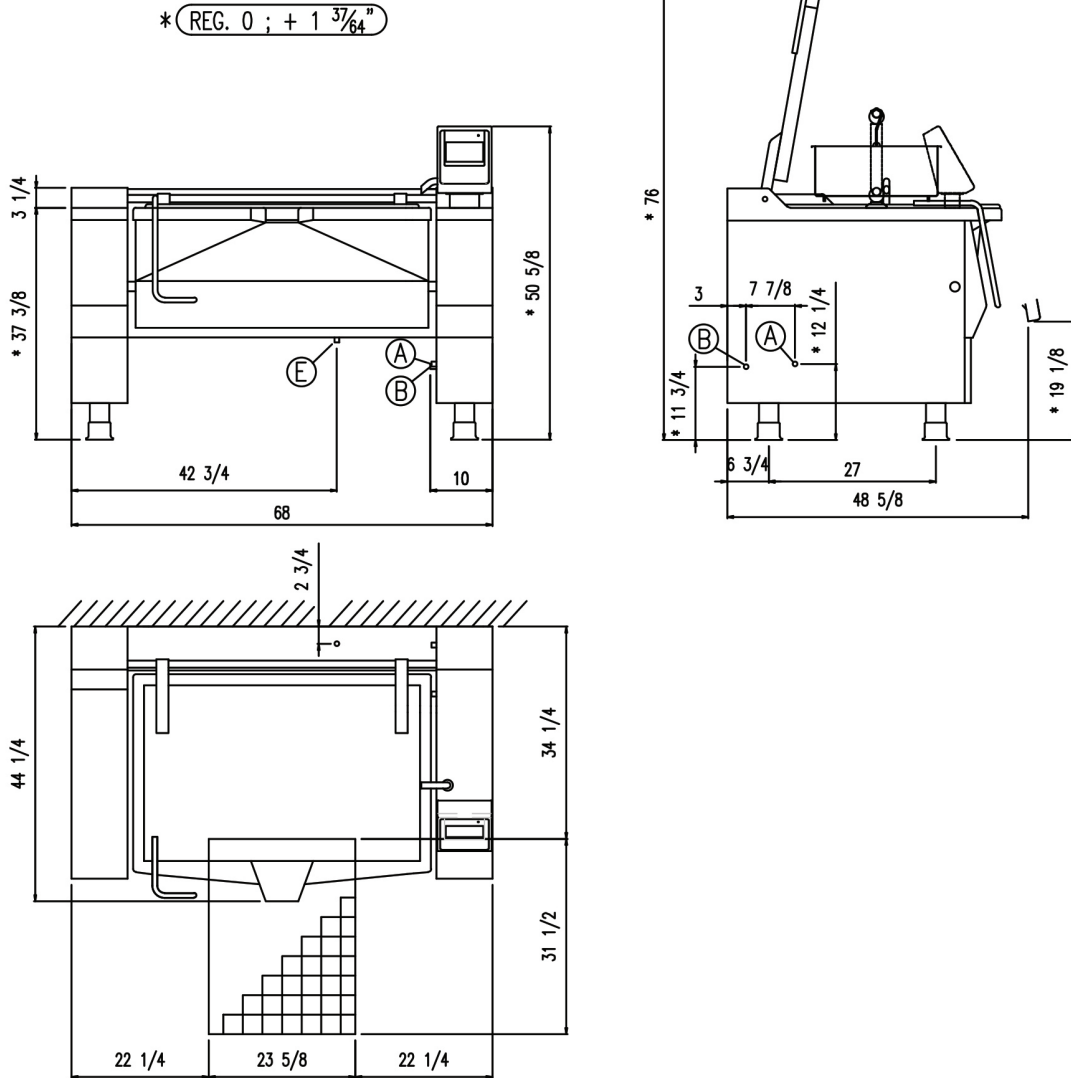

TECHNICAL SPECIFICATIONS

DIMENSIONS						Weight	Capacity	Cooking Vessel Surface
Width	Depth	Height	Vessel Width	Vessel Depth	Vessel Height			
68"	44 1/4"	50 5/8"	41 3/4"	25 5/8"	16 1/2"	1146 lb	38 gal	1069 in ²

UTILITIES					
HOT WATER INLET (A)	COLD WATER INLET (B)	WATER PRESSURE	STD VOLTAGE (E)	ELECTRIC POWER	CURRENT
3/4"	3/4"	25-50 PSI	3 PHASE 208V~ 60Hz	19.80 kW	55.0 A
			3 PHASE 220-240 V~ 60Hz	19.80 kW	47.7 A

**INTENDED FOR COMMERCIAL USE ONLY.
NOT FOR HOUSEHOLD USE.**

