

## ELECTRIC TILT BRAISING PAN

### 48 GALLON

### 143,300 BTU WITH LIFT



UDBRG048CV1

#### General Functional Features

- Heating by means of high efficiency stainless steel tube burners
- Automatic ignition and flame control system without pilot burner
- Temperature control by system with two probes (product/bottom)
- Automatic baskets lifting system by electric engines controlled by electronic card
- Electronic control by means of multifunctional keyboard with Touch Screen 7" and easy and clear messages
- USB connection to download HACCP data, update the software and load cooking programs
- Ability to interrogate the machine using communication protocol MODBUS over RS485 serial interface

#### Panel Board Functions

- ON/OFF switch
- Resistive 7" touch screen
- Keys for moving basin
- Selection of 3 different cooking modes (5 with optional core probe), with working temperature setting
- Core probe (optional)
- Cooking type and time setting
- Set the cooking time using the basket lifters, with possibility to select automatic lowering when the temperature is reached
- Cooking in "Manual" mode
- Cooking in "Program" mode
- Creating and editing multiphase cooking programs, setting for each phase: type of cooking; cooking parameters (temperature and time), and possibility to insert text messages
- Tank water load setting (hot up to 140° F/cold) with automatic liter measurements
- Control for tilting and return of cooking tank from Touch Screen or keyboard
- Delayed cooking setting with date, time, and programming cycle
- Language settings Touch Screen
- Input of different units of measurement (° C/° F; Liters/gallons; etc)

#### Display/Signal

- Display type of cooking, temperature probes used and set temperature
- Heating operating visual alarm
- Time to end of cycle display
- Audible/visible warning of automatic basket movements
- Display tank out of position for cooking
- Signaling tap position, managing water in the tank
- Signal of lid and cock position during vat tilting
- Signaling and blocking heat in case there is no gas
- Gas control unit "RESET" message
- Thermostat intervention safety signaling
- Self-diagnostics

#### Safety System

- Emergency button
- Blocking of heating for excess of temperature with manual resettable safety thermostat
- Heating interruption during vat tilting

#### OPTIONS & ACCESSORIES AT ADDITIONAL COST

- |   |  |  |
|---|--|--|
| <input type="checkbox"/> DAPF0010 - SET FEET        | <input type="checkbox"/> D150 - KIT WHEELS               | <input type="checkbox"/> DABF0000 - CONTAINER WITH HOLES |
| <input type="checkbox"/> DSAC0000 - COREPROBE       | <input type="checkbox"/> DAF0180 - STRAINER              | <input type="checkbox"/> DACF0000 - FRY-BASKET           |
| <input type="checkbox"/> DADE0010 - CLEANING SHOWER | <input type="checkbox"/> DAP01000 - SPATULA FOR OMELETTE |  |

#### STANDARD CONSTRUCTION SPECIFICATIONS

Cooking vessel in stainless steel AISI 304 (bottom thickness 15 mm and wall thickness 2,5 mm) with rounded corner angles and anti-overflowing lip. Vessel with electric tilting on front part

Insulated lid with double cover in stainless steel AISI 304 (thickness 12/10), with ergonomic handle, balanced by means of gas springs

Self-supporting frame in stainless steel AISI 304 (thickness 30-40/10)

Outer cover in stainless steel AISI 304, fine satin finish (thickness 12-15/10)

Adjustable feet in stainless steel AISI 304 to ensure levelling, with removable cover for cleaning operations

Fast accessibility to the main functional parts (electronic card, fuses, thermostats...) only removing the frontal panels

Protection level IPX4



Approval Notes: \_\_\_\_\_

\_\_\_\_\_

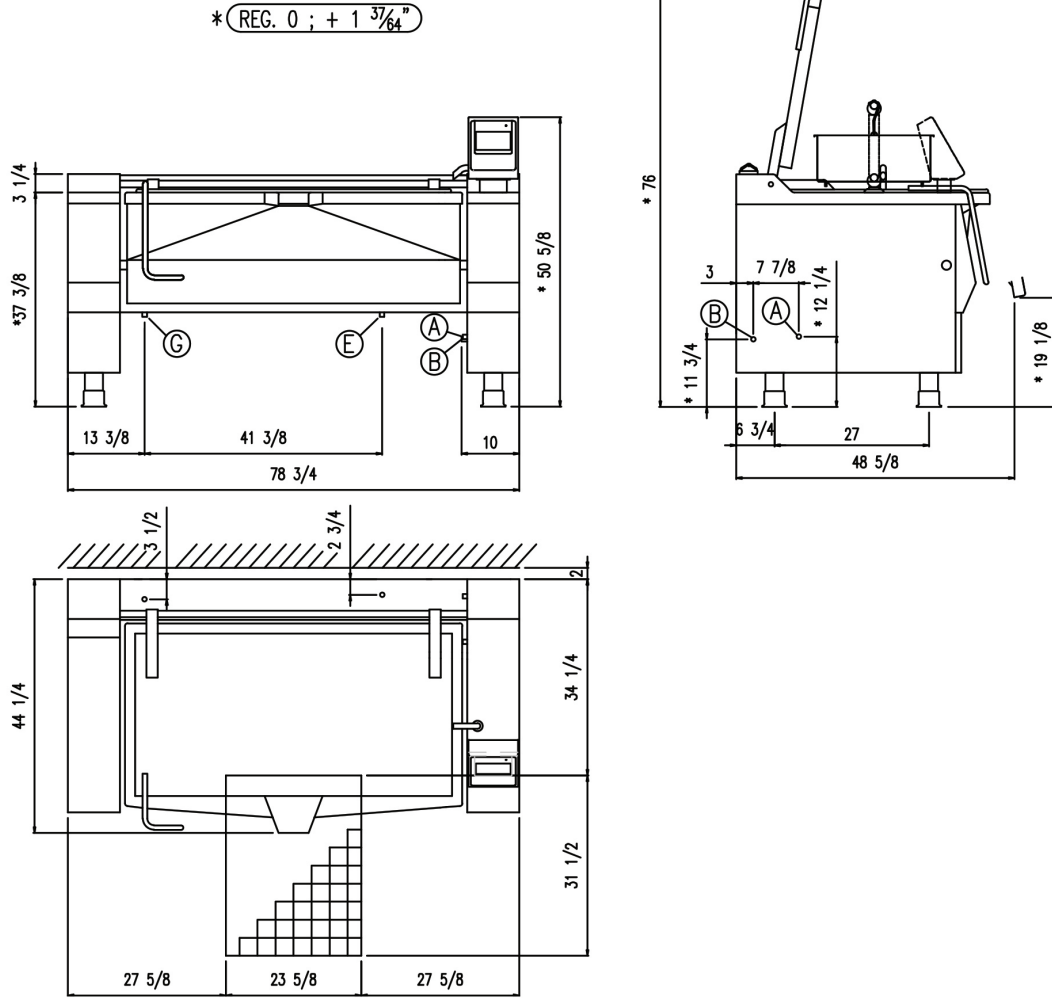

**TECHNICAL SPECIFICATIONS**

DIMENSIONS						Weight	Capacity	Cooking Vessel Surface
Width	Depth	Height	Vessel Width	Vessel Depth	Vessel Height			
78 3/4"	44 1/4"	50 5/8"	52 1/2"	25 5/8"	16 1/2"	1268 lb	48 gal	1348 in <sup>2</sup>

UTILITIES								
HOT WATER INLET (A)	COLD WATER INLET (B)	WATER PRESSURE	GAS CONNECTION (G)	GAS POWER BTU/H	STD VOLTAGE (E)	ELECTRIC POWER	CURRENT	
3/4"	3/4"	25-50 PSI	3/4"	143,500	3 PHASE 208V~ 60Hz	0.50 kW	2.4 A	
					3 PHASE 220-240 V~ 60Hz	0.50 kW	2.1 A	

**INTENDED FOR COMMERCIAL USE ONLY.  
NOT FOR HOUSEHOLD USE.**

