



ELECTRIC CHEESEMELTER

IMPERIAL

IMPERIAL



ICMA-36-E

ELECTRIC ELEMENT

- Two 3 KW incoloy heating elements.
- Independent left and right heating zones maximize function and performance.
- 208 and 240 volts, 3 phase operation

BROILER RACK

- Chrome plated heavy duty rack.
- Loads and unloads easily.
- Full width, large capacity for high production in peak hours.
- Rack easily lifts out for cleaning.

EXTERIOR FEATURES

- Constructed using aluminized steel for maximum heat retention and heat distribution.
- Stainless steel front, sides and top.
- Welded and polished stainless steel seams.
- Mounts over IR and IHR Imperial ranges with mounting accessory.
- Can be wall or counter mounted.
- One year parts and labor warranty.



MADE IN USA

IMPERIAL

1128 Sherborn Street | Corona, CA 92879 | 800.343.7790 | imperialrange.com | imperialsales@imperialrange.com

©2024 Imperial Commercial Cooking Equipment Imperial reserves the right to change specifications at any time without prior notice and without any obligation for past or future equipment purchases. Visit www.imperialrange.com for specification updates



ELECTRIC CHEESEMELTER

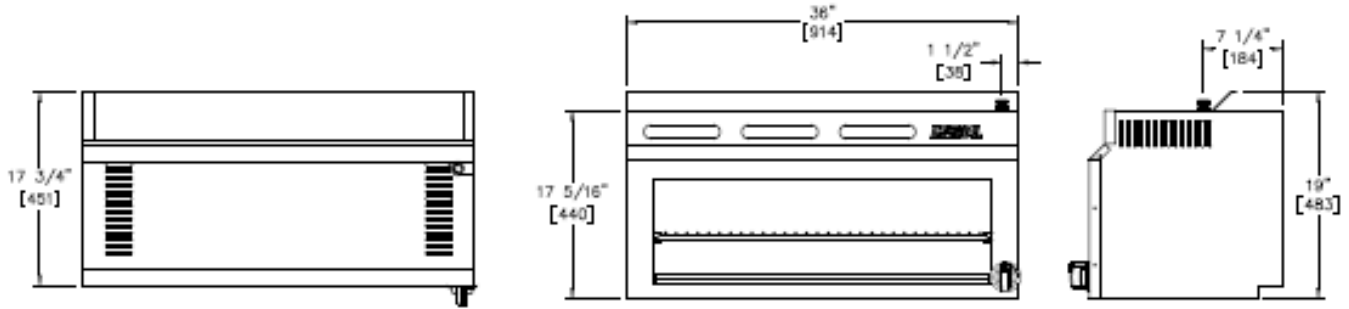

CHEESEMELTER

MODEL	DESCRIPTION	DIMENSIONS	CRATED DIMENSIONS	ELEMENTS KW	ELEMENTS NUMBER	SHIP WEIGHT KG	SHIP WEIGHT LBS
ICMA-36-E	CHEESEMELTER	36" W X 17 3/4" D X 17 1/4" H (914 X 451 X 438 MM)	38" W X 20" D X 21" H (965 X 508 X 533 MM)	3 KW ea.	2	75	162

ELECTRICAL REQUIREMENTS

MODEL	TOTAL KM	VOLTS	PH	AMPS
ICMA-36-E	6	208	3	17
	6	240	3	14
	6	480	3	7

CLEARANCE REQUIREMENTS

For use only on non-combustible surfaces. Legs are required for counter top installation. Provide 0" clearance from non-combustible surfaces and 8" (203 mm) from combustible surfaces.



MADE IN USA

OPTIONS AND ACCESSORIES

- Wall mounting kit
- 4" (102 mm) leg kit for counter mounting
- Reinforcement channels to mount on range



1128 Sherborn Street | Corona, CA 92879 | 800.343.7790 | imperialrange.com | imperialsales@imperialrange.com

© 2024 Imperial Commercial Cooking Equipment Imperial reserves the right to change specifications at any time without prior notice and without any obligation for past or future equipment purchases. Visit www.imperialrange.com for specification updates