



GAS

TUBE FIRED FRYER 75 LBS.

IMPERIAL



IFS-75



Robotic welding is precise, virtually eliminating leaks.

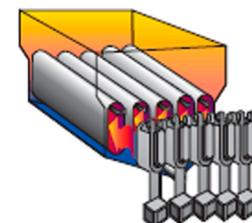

Tube fired burners have a large heat transfer area.

TUBE FIRED BURNERS

- High efficiency cast iron burners have a large heat transfer area.
- Tubes are constructed of heavy gauge metal with a built-in deflector system.
- 175,000 BTU (51 KW) total output.
- Millivolt temperature control circuit
- Snap acting electronic thermostat has a 200°F - 400°F, (93°C - 204°C) temperature range that extends oil life and produces a uniformly cooked product.
- Fast recovery to desired temperature.
- Heats oil quickly producing a better tasting product with less oil absorption.
- 100% safety shut-off
- Millivolt temperature control circuit

EXTERIOR FEATURES

- Stainless steel front, door, sides, basket hanger and frypot.
- Welded and polished stainless steel seams.
- Full heat shield protects control panel.
- Full bottom chassis provides structural support.
- Plate mounted 6" (152 mm) heavy duty stainless steel legs or optional casters assure secure support.
- One year parts and labor warranty. Limited warranty on frypot, stainless steel frypot is five years pro-rated.

STAINLESS STEEL FRYPOTS

- Large 18" x 18" (457 x 457 mm) frying area.
- Frypot tubes and sides are robotically welded stainless steel to virtually eliminate leaks.
- Fine mesh wire crumb is included.
- Deep drawn bottom facilitates draining, slants toward the drain.
- 1-1/4" (32 mm) full port drain valve empties frypot quickly and safely.
- Two large, nickel-plated fry baskets with vinyl coated, heat protection, handles are included.
- Basket hangers are stainless steel.

LARGE COOL ZONE

- Captures and holds particles out of the fry zone
- Reduces taste transfer



GAS

TUBED FIRED FRYER - 75 LB

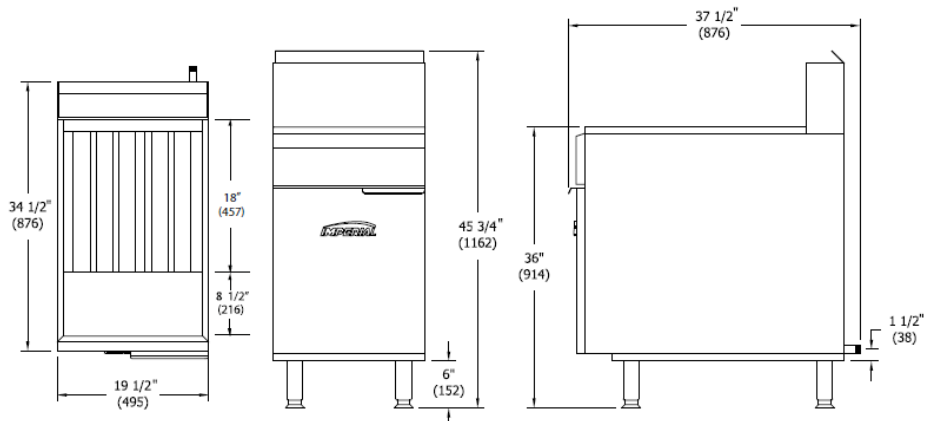

MODEL	OIL CAPACITY	GAS OUTPUT		#OF BURNERS	SHIP WEIGHT (KG) LBS
		BTU	(KW)		
IFS-75	75 lbs. (41 L)	175,000	(51)	5	(122) 270
IFS-DS	N/A	N/A	N/A	N/A	(60) 130

MANIFOLD PRESSURE		MANIFOLD SIZE
NAT GAS	PROPANE	
4.0" W.C.	11.0" W.C.	3/4"

Specify elevation, if over 2,000 ft.

MODEL	FRYER AREA	DIMENSIONS			CRATED DIMENSIONS		
		W	D	H	W	D	H
IFS-75	18" X 18" (457 X 457 mm)	19 1/2" W (495)	34 1/2" D (876)	45 3/4" H (1162)	22" W (559)	37" (940)	35" (889)
IFS-DS	N/A	19 1/2" W (495)	34 1/2" D (876)	44 1/4" H (1124)	22" W (559)	37" (940)	35" (889)

OPTIONS AND ACCESSORIES

- Fryer drain station with storage cabinet
- Manual timer
- Catering package for easy transporting
- Extra fry baskets with vinyl coated handles
- Gas shut off valve, 3/4" N.P.T.
- Quick disconnect and flexible gas hose, 3/4" N.P.T.
- 6" (152 mm) casters

CLEARANCE REQUIREMENTS

For use only on non-combustible floors. Legs or casters are required for non-combustible floors. Provide 0" clearance from non-combustible surfaces and 6" (152 mm) from combustible surfaces.

Measurements in () are metric equivalents



MADE IN USA



1128 Sherborn Street | Corona, CA 92879 | 800.343.7790 | imperialrange.com | imperialsales@imperialrange.com

©2024 Imperial Commercial Cooking Equipment. Imperial reserves the right to change specifications at any time without prior notice and without any obligation for past or future equipment purchases. Visit www.imperialrange.com for specification updates