



GAS

TUBE FIRED FRYERS/FILTERS SIDE CAR FILTER SYSTEMS



IFSCB250

Filter System with drain station

MODEL NUMBERS

- IFSCB150 IFSCB450
- IFSCB175 IFSCB475
- IFSCB250 IFSCB550
- IFSCB275 IFSCB575
- IFSCB350 IFSCB650
- IFSCB375 IFSCB675

FILTER PACKAGE CHOICES

- Up to six fryers can be battered into one fryer / filter system.
- Available for 50 and 75 lb. (27 and 41 Liters) oil capacity fryers.
- Available in Snap Action Thermostats, Electronic Thermostats or Computer Controls.

LOCATED UNDER FRYERS

- Filter location under fryers saves valuable space.
- Internally plumbed oil drain and return line.

UNIQUE FILTER PAN DESIGN

- Filter pan is designed for maximum oil return.
- Stainless steel construction is easy to clean and has a professional look.
- Positive-latching filter paper holder holds paper in place for optimal filtration.
- Quick disconnect connection offers quick and safe connection of the filtered oil back into the frypots.
- All oil drain and return lines are internally plumbed for convenience and safety.

ROLLER-PUMP

- 5.5 GPM pump with a 1/3 HP motor speeds up filtering process.
- Can pump oil into a disposal vat up to 20 feet away.
- Reclamation system

DRAIN STATION

- Includes a matching stainless steel cabinet with a food warmer and dump pan.
- Cabinet may be located anywhere within the fryer battery.
- Cabinet is a convenient storage area when located at the end of the battery.

EXTERIOR FEATURES

- Continuous cabinet provides a professional look.
- 5" (127 mm) deep continuous stainless steel front landing ledge.
- Stainless steel precision welded frypot.
- Includes casters, joiner strips and filter starter kit.
- Rear gas manifold with one point gas connection.



GAS

TUBE FIRED FRYERS/FILTERS SIDE CAR FILTER SYSTEMS

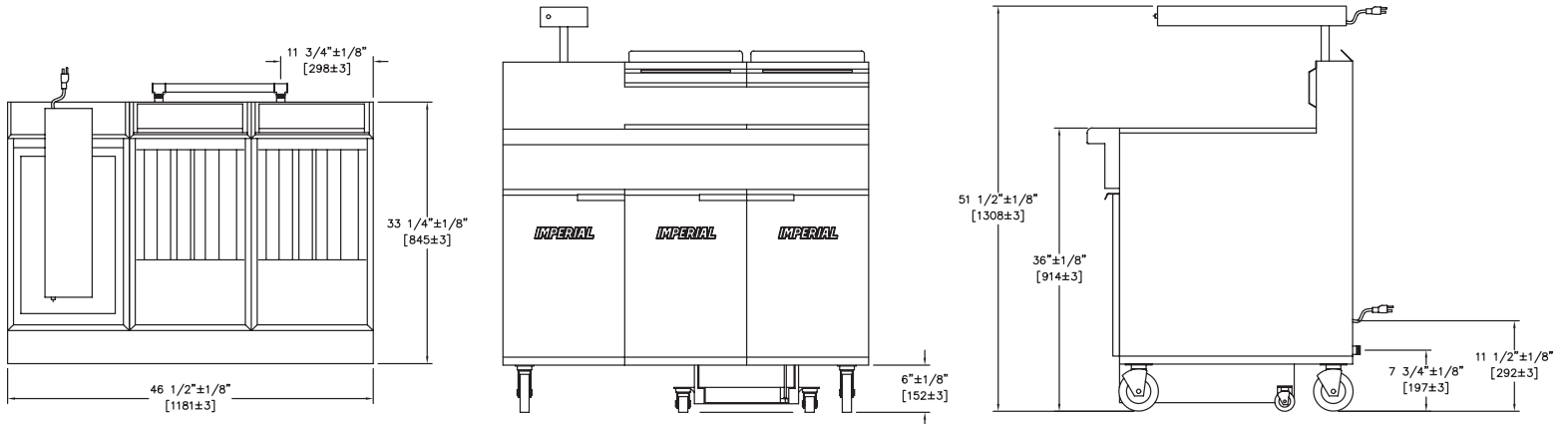

MODEL	OIL CAPACITY	WIDTH	FRYERS	SHIP WEIGHT KG	SHIP WEIGHT LBS
IFSCB150	50 LBS. (41 L)	31" (787 MM)	1	196	433
IFSCB250	50 LBS. (41 L)	46-1/2" (1181 MM)	2	311	686
IFSCB350	50 LBS. (41 L)	62" (1575 MM)	3	426	939
IFSCB450	50 LBS. (41 L)	77-1/2" (1969 MM)	4	541	1192
IFSCB550	50 LBS. (41 L)	93" (2362 MM)	5	655	1445
IFSCB650	50 LBS. (41 L)	108-1/2" (2756 MM)	6	770	1698
IFSCB175	75 LBS. (51 L)	39" (911 MM)	1	204	450
IFSCB275	75 LBS. (51 L)	58-1/2" (1486 MM)	2	327	720
IFSCB375	75 LBS. (51 L)	78" (1981 MM)	3	449	990
IFSCB475	75 LBS. (51 L)	97-1/2" (2477 MM)	4	572	1260
IFSCB575	75 LBS. (51 L)	117" (2972 MM)	5	694	1530
IFSCB675	75 LBS. (51 L)	136-1/2" (3467 MM)	6	816	1800

FILTER ELECTRICAL REQUIREMENT			
VOLTS	PHAZE	HERTZ	AMPS
115 V	1	60	6.8 AMPS

6ft. (1829 mm) power cord with 3 prong plug provided

CLEARANCE

For use only on non-combustible floors with legs or casters. Provide 0" clearance from non-combustible surfaces and 6" (152 mm) from combustible surfaces.

OPTIONS AND ACCESSORIES

- Automatic basket lifts with computerized controls
- Manual controlled basket lifts
- Gas shut off valve, 3/4" N.P.T.
- Stainless steel tank cover
- Stainless steel side drain shelf
- Stainless steel side splash, 6"
- Filter paper 40# thickness, 20 microns, 100 sheets per box



MODEL	DIMENSIONS	CRATED DIMENSIONS
IFSCB150	31" W X 33-1/4" D X 51-1/2" H (787 X 845 X 1308 MM)	32-1/2" W X 38" D X 40" H (826 X 965 X 1016 MM)
IFSCB250	46-1/2" W X 33-1/4" D X 51-1/2" H (1181 X 845 X 1308 MM)	48" W X 38" D X 40" H (1219 X 965 X 1016 MM)
IFSCB350	62" W X 33-1/4" D X 51-1/2" H (1575 X 845 X 1308 MM)	63-1/2" W X 38" D X 40" H (1613 X 965 X 1016 MM)
IFSCB450	77-1/2" W X 33-1/4" D X 51-1/2" H (1969 X 845 X 1308 MM)	79" W X 38" D X 40" H (2007 X 965 X 1016 MM)
IFSCB550	93" W X 33-1/4" D X 51-1/2" H (2362 X 845 X 1308 MM)	94-1/2" W X 38" D X 40" H (2400 X 965 X 1016 MM)
IFSCB650	108-1/2" W X 33-1/4" D X 51-1/2" H (2756 X 845 X 1308 MM)	110" W X 38" D X 40" H (2794 X 965 X 1016 MM)

MODEL	DIMENSIONS	CRATED DIMENSIONS
IFSCB175	39" W X 40-1/2" D X 45-3/4" H (911 X 1029 X 1162 MM)	40-1/2" W X 43" D X 49-1/2" H (1029 X 1092 X 1257 MM)
IFSCB275	58-1/2" W X 40-1/2" D X 45-3/4" H (1486 X 1029 X 1162 MM)	60" W X 43" D X 49-1/2" H (1524 X 1092 X 1257 MM)Z
IFSCB375	78" W X 40-1/2" D X 45-3/4" H (1981 X 1029 X 1162 MM)	79-1/2" W X 43" D X 49-1/2" H (2019 X 1092 X 1257 MM)
IFSCB475	97-1/2" W X 40-1/2" D X 45-3/4" H (2477 X 1029 X 1162 MM)	99" W X 43" D X 49-1/2" H (2515 X 1092 X 1257 MM)
IFSCB575	117" W X 40-1/2" D X 45-3/4" H (2972 X 1029 X 1162 MM)	118-1/2" W X 43" D X 49-1/2" H (3010 X 1092 X 1257 MM)
IFSCB675	136-1/2" W X 40-1/2" D X 45-3/4" H (3467 X 1029 X 1162 MM)	138" W X 43" D X 49-1/2" H (3505 X 1092 X 1257 MM)