

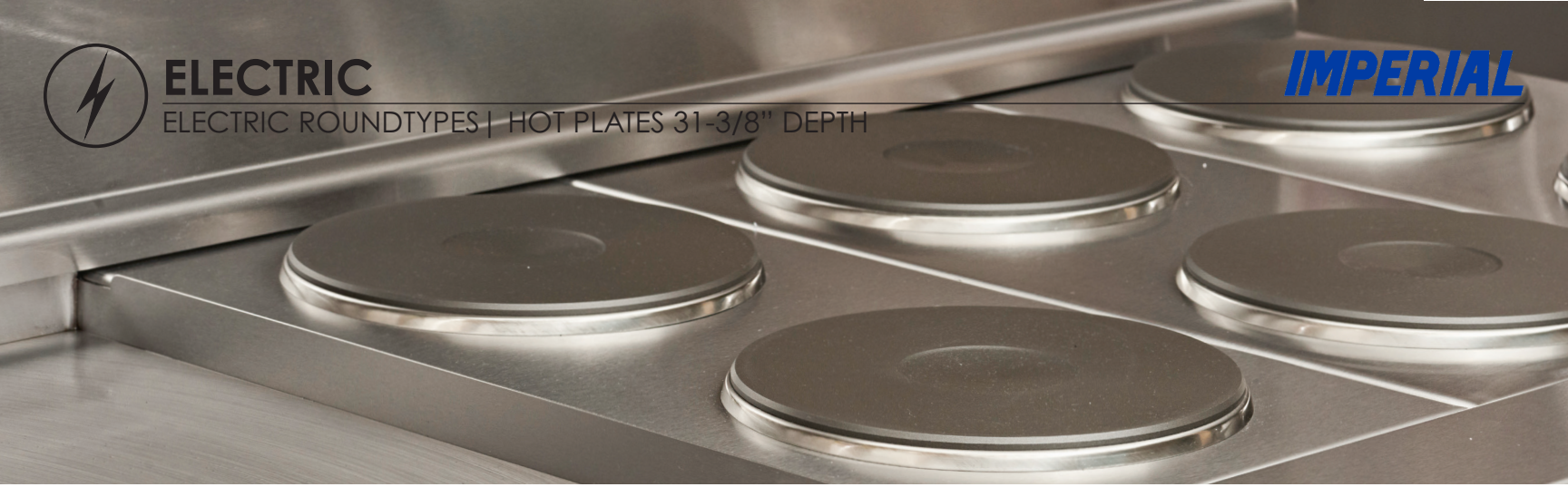

ELECTRIC

ELECTRIC ROUNDTYPES | HOT PLATES 31-3/8" DEPTH

IMPERIAL



IHPA-6-36-E

Model Numbers

IHPA-2-12-E
IHPA-4-24-E
IHPA-6-36-E
IHPA-8-48-E
IHPA-10-60-E



9" (229 MM) SEALED ROUND
PLATE ELEMENTS WITH EASY TO
CLEAN FLAT SURFACE.



LARGE 5" (127 MM) STAIN-
LESS STEEL LANDING LEDGE
FOR CONVENIENT PLATING.

ROUND PLATE ELEMENTS

- 2 KW round plate elements with easy-to-clean flat surface.
- Provides a solid flat surface for fast, even heating.
- Plates are 9" (229) diameter for maximum pan contact.
- Solid top prevents spills from entering unit making clean-up easy.
- Infinite heat controls for maximum cooking flexibility.

EXTERIOR FEATURES

- Stainless steel front, top and sides for cleanability and professional look.
- Welded and polished stainless steel seams.
- Range match profile when placed on a refrigerated base or equipment stand.
- Large 5" (127 mm) stainless steel landing ledge is ideal for plating.
- 4" (102 mm) heavy duty legs with adjustable feet.
- One year parts and labor warranty.



ELECTRIC

ELECTRIC ROUNDTYPES | HOT PLATES 31-3/8" DEPTH

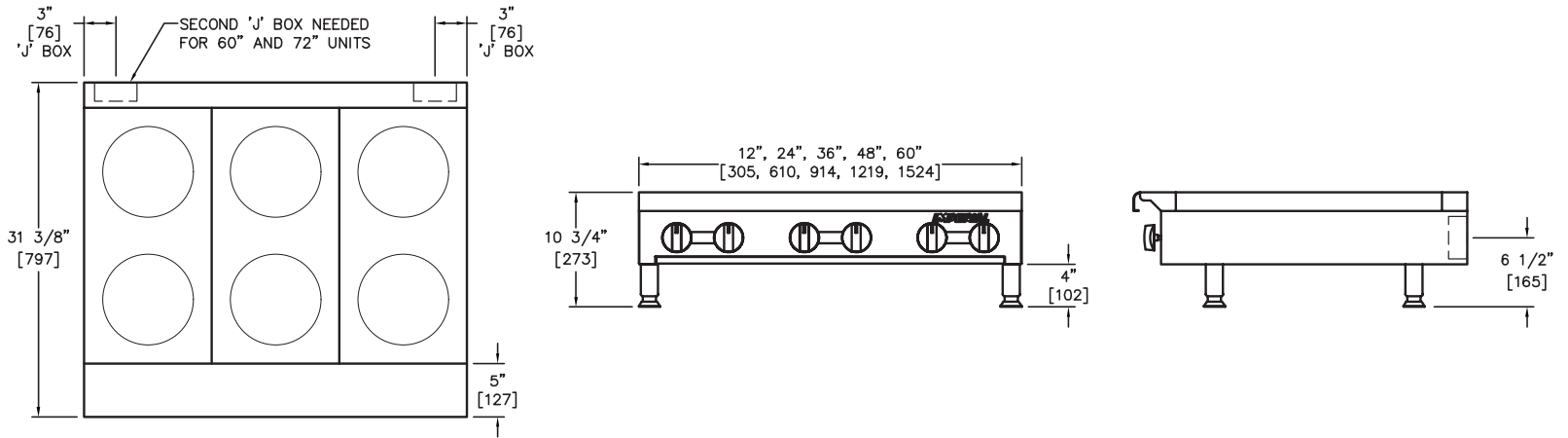

ELECTRIC HOT PLATES - 31-3/8" (797 MM) DEPTH

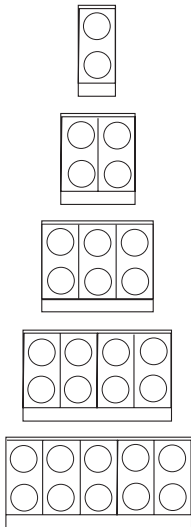

MODEL	WIDTH INCHES (MM)	ROUND ELEMENTS	OUTPUT KW	SHIP WEIGHT	
				KG	LBS
IHPA-2-12-E	12" (305)	2	4	37	80
IHPA-4-24-E	24" (610)	4	8	64	140
IHPA-6-36-E	36" (914)	6	12	95	210
IHPA-8-48-E	48" (1219)	8	16	123	270
IHPA-10-60-E	60" (1524)	10	20	147	325

MODEL	DIMENSIONS	CRATED DIMENSIONS	
		INCHES	MM
IHPA-2-12-E	12" W X 31-3/8" D X 10-3/4" H (305 X 797 X 273 MM)	14-1/2" W X 35" D X 12" H (368 X 889 X 324 MM)	
IHPA-4-24-E	24" W X 31-3/8" D X 10-3/4" H (610 X 797 X 273 MM)	26-1/2" W X 35" D X 12" H (673 X 889 X 324 MM)	
IHPA-6-36-E	36" W X 31-3/8" D X 10-3/4" H (914 X 797 X 273 MM)	38-1/2" W X 35" D X 12" H (978 X 889 X 324 MM)	
IHPA-8-48-E	48" W X 31-3/8" D X 10-3/4" H (1219 X 797 X 273 MM)	50-1/2" W X 35" D X 12" H (1283 X 889 X 324 MM)	
IHPA-10-60-E	60" W X 31-3/8" D X 10-3/4" H (1524 X 797 X 273 MM)	62-1/2" W X 35" D X 12" H (1588 X 889 X 324 MM)	

AMPERAGE REQUIREMENTS				
MODEL	TOTAL KW	VOLTS	PH	AMPS
IHPA-2-12-E	4	208	1	19
	4	208	3	14
	4	240	1	17
	4	240	3	13
IHPA-4-24-E	4	480*	3	6
	8	208	1	39
	8	208	3	29
	8	240	1	33
IHPA-6-36-E	8	240	3	25
	8	480*	3	13
	12	208	1	58
	12	208	3	38
IHPA-8-48-E	12	240	1	50
	12	240	3	33
	12	480*	3	17
	16	208	1	77
	16	208	3	58
	16	240	1	67
	16	240	3	50
	16	480*	3	25

CLEARANCE REQUIREMENTS

For use only on non-combustible surfaces. Provide 0" clearance from non-combustible surfaces and 8" (203 mm) from combustible surfaces

OPTIONS AND ACCESSORIES

- Stainless steel equipment stands
- 6" (152 mm) casters for equipment stands
- 480 volts (additional charge)



AMPERAGE REQUIREMENTS					
MODEL	TOTAL KW	VOLTS	PH	AMPS J-BOX	
				A	B
IHPA-10-60-E	20	208	1	48	48
	20	208	3	43	43
	20	240	1	42	42
	20	240	3	37	37
	20	480*	3	19	19