

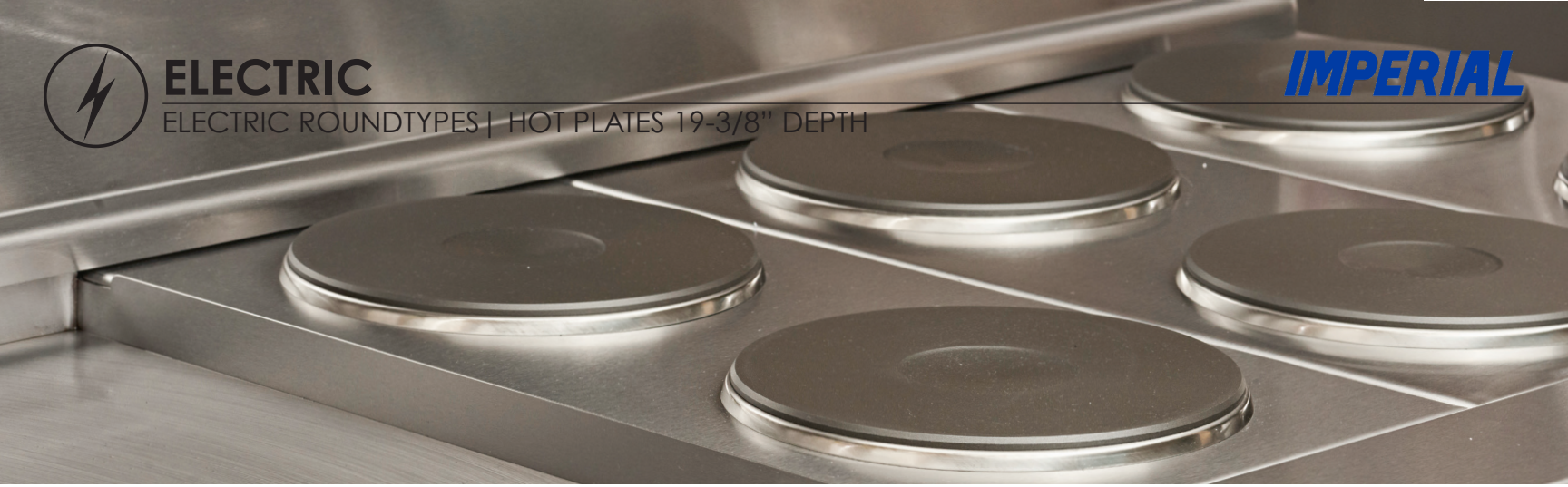

**ELECTRIC**

ELECTRIC ROUNDTYPES | HOT PLATES 19-3/8" DEPTH

**IMPERIAL**



## IHPA-3-36-E

Model Numbers

IHPA-1-12-E

IHPA-2-24-E

IHPA-3-36-E

IHPA-4-48-E



9" (229 MM) SEALED ROUND PLATE ELEMENTS WITH EASY TO CLEAN FLAT SURFACE.



LARGE 5" (127 MM) STAINLESS STEEL LANDING LEDGE FOR CONVENIENT PLATING.

## ROUND PLATE ELEMENTS

- 2 KW round plate elements with easy-to-clean flat surface.
- Provides a solid flat surface for fast, even heating.
- Plates are 9" (229) diameter for maximum pan contact.
- Solid top prevents spills from entering unit making clean-up easy.
- Infinite heat controls for maximum cooking flexibility.

## EXTERIOR FEATURES

- Stainless steel front, top and sides for cleanability and professional look.
- Welded and polished stainless steel seams.
- Range match profile when placed on a refrigerated base or equipment stand.
- Large 5" (127 mm) stainless steel landing ledge is ideal for plating.
- Control knobs are durable cast aluminum with a Valox™ "cool to the touch" grip.
- 4" (102 mm) heavy duty legs with adjustable feet.
- One year parts and labor warranty.



# ELECTRIC

ELECTRIC ROUNDTYPES | HOT PLATES 19-3/8" DEPTH

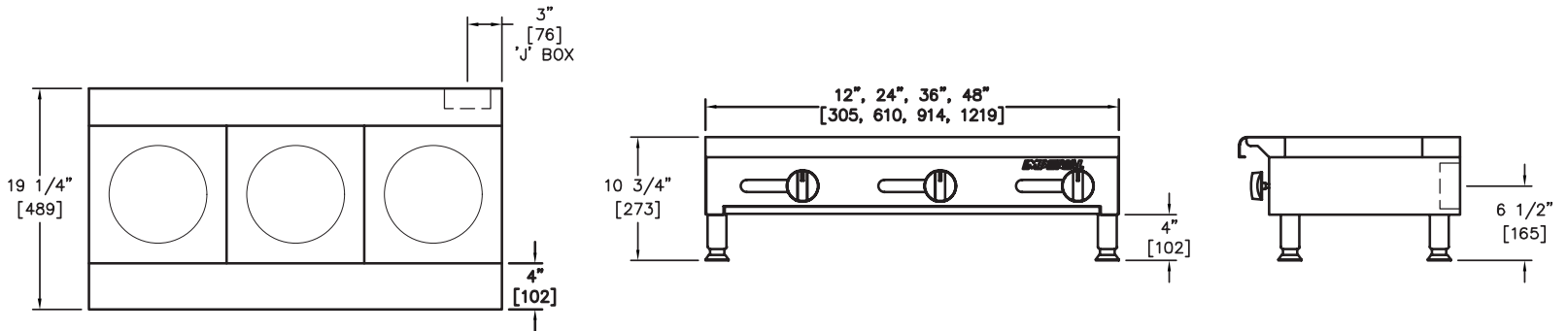

## ELECTRIC HOT PLATES - 19-3/8" (492 MM) DEPTH

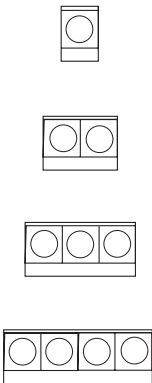

MODEL	WIDTH INCHES (MM)	ROUND ELEMENTS	OUTPUT KW	SHIP WEIGHT	
				KG	LBS
IHPA-1-12-E	12" (305)	1	2	21	45
IHPA-2-24-E	24" (610)	2	4	37	80
IHPA-3-36-E	36" (914)	3	6	53	115
IHPA-4-48-E	48" (1219)	4	8	64	140

MODEL	DIMENSIONS	CRATED DIMENSIONS
IHPA-1-12-E	12" W X 19-3/8" D X 10-3/4" H (305 X 492 X 273 MM)	14-1/2" W X 23" D X 12" H (368 X 584 X 324 MM)
IHPA-2-24-E	24" W X 19-3/8" D X 10-3/4" H (610 X 492 X 273 MM)	26-1/2" W X 23" D X 12" H (673 X 584 X 324 MM)
IHPA-3-36-E	36" W X 19-3/8" D X 10-3/4" H (914 X 492 X 273 MM)	38-1/2" W X 23" D X 12" H (965 X 584 X 324 MM)
IHPA-4-48-E	48" W X 19-3/8" D X 10-3/4" H (1219 X 492 X 273 MM)	50-1/2" W X 23" D X 12" H (1283 X 584 X 324 MM)

MODEL	AMPERAGE REQUIREMENTS			
	TOTAL KW	VOLTS	PH	AMPS
IHPA-1-12-E	2	208	1	10
	2	240	1	8
IHPA-2-24-E	4	208	1	19
	4	208	3	14
	4	240	1	17
	4	240	3	13
IHPA-3-36-E	4	480*	3	6
	6	208	1	29
	6	208	3	17
	6	240	1	25
IHPA-4-48-E	6	240	3	15
	6	480*	3	17
	8	208	1	39
	8	208	3	29
	8	240	1	33
	8	240	3	25
	8	480*	3	13

### CLEARANCE REQUIREMENTS

For use only on non-combustible surfaces. Provide 0" clearance from non-combustible surfaces and 8" (203 mm) from combustible surfaces

### OPTIONS AND ACCESSORIES

- Stainless steel equipment stands
- 6" (152 mm) casters for equipment stands
- 480 volts (additional charge)

