



GAS

SPEC SERIES | OPEN BURNERS

IMPERIAL



IHR-6

Shown with optional casters.

Model Numbers

IHR-6	IHR-4
IHR-6-C	IHR-4-C
IHR-6-XB	IHR-4-XB
IHR-6-M	IHR-4-M

OPEN BURNERS

- Anti-clogging burner
- 35,000 BTU/hr (10 KW) output with 7,000 BTU/hr low simmer feature.
- One piece Venturi base has no gaskets. Venturi slopes down to the burner creating more efficient heating
- Cast-Iron burners remove and separate for cleaning
- All stainless-steel tubing and solid brass components for a long service life

STANDARD OVEN

- 40,000 BTU/hr (12KW) oven with 100% safety pilot and manual shut off valve
- Unique burner baffle distributes heat flow to provide even temperatures throughout the oven cavity
- Exclusive heat deflector reflects heat into the oven, not the floor
- Chef Depth interior is 26 ½" W x 26" D x 14" H (673 x 660 x 356 mm) and accommodates 18" x 26" (457 x 660) sheet pans left-to-right and front-to-back
- Porcelainized sides, rear, deck and door lining for easy cleaning.
- Superior heavy-duty door hinge
- Side oven controls are protected in the cool zone
- One chrome oven rack is included.
- Optional stainless steel oven interior
- Optional high mass oven with cast iron oven interior and 650 degree thermostat

CONVECTION OVEN

- 35,000 BTU/hr (1KW) Convection oven with ½ HP blower motor cooks products quickly and evenly with less shrinkage
- Electronic ignition system with Radiant solenoid valves
- Convection oven interior dimensions 26 ½" W x 22 ½" D x 14" H (673 x 572 x 356 mm)
- Three positions switch for cooking or cool down. Fan shuts off automatically when the door is open
- Porcelainized sides, rear, deck and inner door liner for easy cleaning. Stainless steel door gasket
- Burner "ON" indicator light and one hour electronic timer
- Three chrome oven racks are included.

GRATES

- S Grates are standard on all units, optional spider grates are available
- IHR-6 series grates measure 12" x 14" (305 x 356 mm).
- IHR-4 Series measures 18" x 14" (457 x 356 mm)
- Anti-Clogging shield design into the grate protects the pilot from grease and debris



GAS

SPEC SERIES | OPEN BURNERS

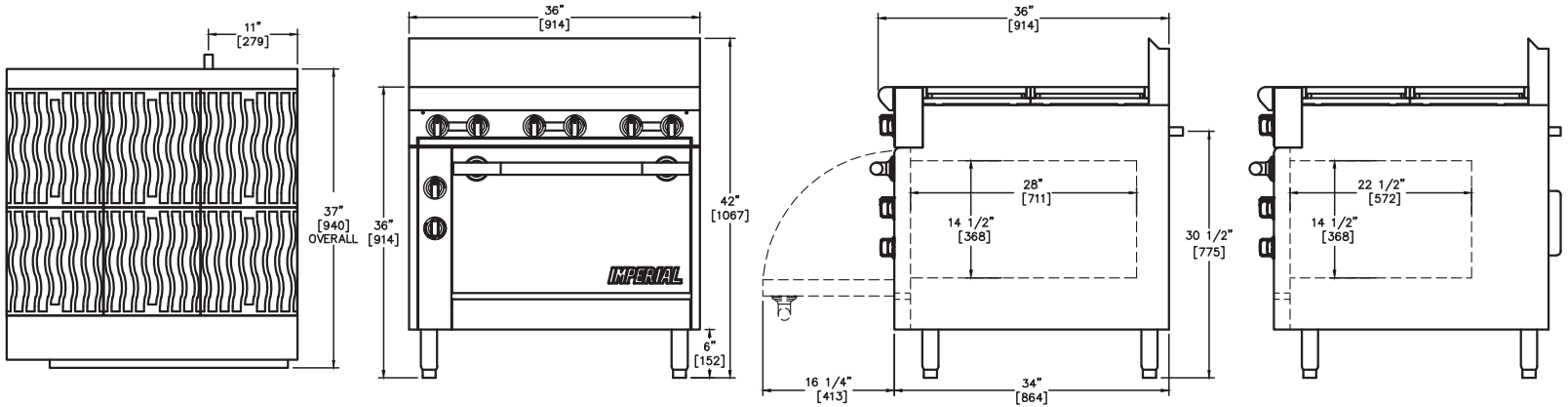

SIX 40,000 BTU OPEN BURNERS

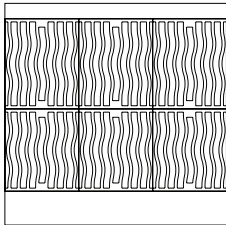

MODEL	GAS OUTPUT		OPEN BURNERS	SHIP WEIGHT	
	BTU	KW		KG	LBS
IHR-6	280,000	82	6	338	745
IHR-6-C	275,000	81	6	366	805
IHR-6-XB	240,000	70	6	261	575
IHR-6-M	240,000	70	6	182	400

MANIFOLD PRESSURE		
NATURAL GAS	PROPANE GAS	MANIFOLD SIZE
5.0" W.C.	10.0" W.C.	3/4" (19 MM)

CLEARANCE REQUIREMENTS

For use only on non-combustible floors. Legs or casters are required for non-combustible floors; or 2" (51 mm) overhang is required when curb mounted. Provide 0" clearance from non-combustible surfaces and 8" (203 mm) from combustible surfaces.

Notes:

"C" specifies (1) 26-1/2" (673 mm) Convection Oven
 "M" specifies Modular, Counter Top Model
 "XB" specifies (1) Cabinet Base

Dimensions:

36" w x 38" d x 36" h* (914 x 965 x 914 mm)

* to cooktop

Crated Dimensions:

39-1/2" w x 41" d x 35" h (1003 x 1041 x 889 mm)

Measurements in () are metric equivalents.



FOUR 40,000 BTU OPEN BURNERS 18"

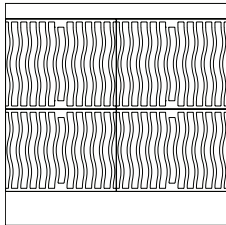

MODEL	GAS OUTPUT		OPEN BURNERS	SHIP WEIGHT	
	BTU	KW		KG	LBS
IHR-4	200,000	59	4	336	740
IHR-4-C	195,000	57	4	363	800
IHR-4-XB	160,000	47	4	259	570
IHR-4-M	160,000	47	4	180	396

OPTIONS AND ACCESSORIES

- Heavy duty stainless steel backguards
- Salamander or Cheesemelter Infra-red Broilers
- Reinforcement channels for mounting cheesemelter/salamander
- Stainless steel common front landing ledge 54", 72", 90", 108" (1372, 1829, 2286, 2743 mm)
- Stainless steel 10" (245 mm) wok ring, fits over open burner top grate
- Stainless steel interior and double doors on open cabinet base
- Stainless steel center shelf in open cabinet base
- Extra chrome racks
- 3/4" rear gas connection for single unit connection
- 1-1/4" rear gas connection batteries up to 600,000 BTU (176 KW)
- Gas shut off valve, 3/4" or 1-1/4", N.P.T.
- Gas pressure regulator, 3/4" or 1-1/4", N.P.T.
- Quick disconnect and flexible gas hose, 3/4" or 1-1/4", N.P.T.
- 6" (152 mm) casters

EXTERIOR

- Sleek European styling with wide radius ledge and optional high shelf
- Stainless steel front, sides, backguard, shelf, landing ledge and kick plate
- Welded and polished stainless steel seams
- Enclosed front 1-1/4" (32 mm) manifold
- Common ledges, backguards and shelves are available as options for a seamless, professional look
- Large 5" (178 mm) stainless steel landing ledge
- Unique cast aluminum control knobs feature a heat protection grip
- 6" (152 mm) high 2-1/2" (64 mm) diameter heavy duty legs with adjustable feet
- One year parts and labor warranty

