



GAS

SPEC SERIES | RANGE MATCH FRYERS

IMPERIAL



IHR-F50

Model Numbers

IHR-F2525 IHR-F50 IHR-F-DS-75
IHR-F75 IHR-F-DS

TUBE FIRED BURNERS

- High efficiency cast iron burners have a large heat transfer area.
- Tubes are constructed of heavy gauge metal with a built-in deflector system
- 140,000 BTU (41 KW) total output for 25/25 and 50 lb models and 175,000 BTU (51 KW) for the 75 lbs model
- Millivolt temperature control circuit
- Snap acting thermostat has 200F- 400F (93C-204C) temperature range
- Fast recovery to desire temperature
- Heats Oil quick producing a better tasting product with less oil absorption – 100% safety shut off valve

LARGE COOL ZONE

- Captures and holds particles below the tubes, out of the fry zone.
- Reduces taste transfer

STAINLESS STEEL FRYPOT

- Frying area for the two 25 lbs models is 6 3/4" x 14" (171 x 356 mm) 14" x 14" (356 x 356 mm) for the 50 lbs model and 18" x 18" (457 x 457 mm) for the 75 lb model
- Frypot tubes and sides are robotically welding stainless steel to virtually eliminates leaks
- Fine mesh wire crumb is included
- Recessed bottom facilitates draining, slants towards the drain
- 1 1/4" (32 mm) full port drain valve empties frypot quickly and safely
- Two large, nickel-plated fry baskets with vinyl coated, heat protection, handles are included
- Basket hangers are stainless steel

EXTERIOR FEATURES

- Welded and polished stainless-steel seams
- Full heat shield protects control panel
- Full bottom chassis provide structural support
- Plate mounted 6" high (152 mm) heavy duty stainless steel legs or optional casters assures support
- One year parts and labor warranty. Limited warranty of frypot, stainless steel frypot is five year pro-rated

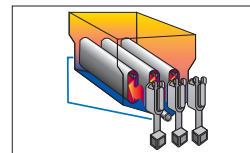

TUBE FIRED BURNERS HAVE A LARGE HEAT TRANSFER AREA.

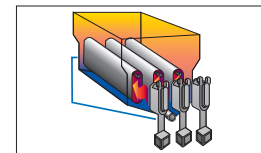

LARGE COOL ZONE CAPTURES AND HOLD PARTICLES OUT OF THE FRY ZONE.

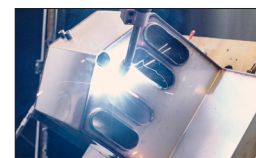

ROBOTIC WELDING IS PRECISE, VIRTUALLY ELIMINATING LEAKS.



GAS

SPEC SERIES | RANGE MATCH FRYERS

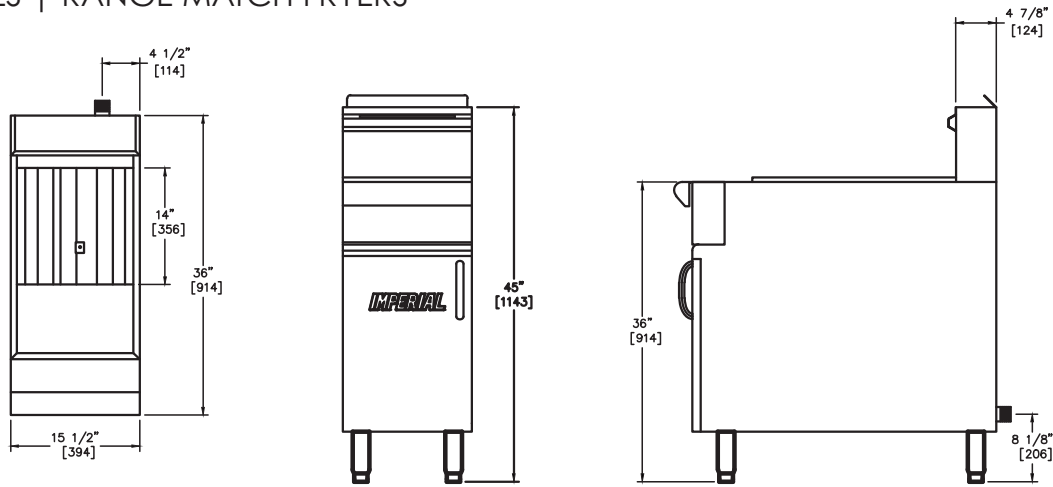

RANGE MATCH FRYERS

MODEL	OIL CAPACITY		GAS OUTPUT		BURNERS	SHIP WEIGHT	
	LB	LTR	BTU	KW		KG	LBS
IHR-F2525	25/25	14/14	140,000	41	4	135	299
IHR-F50	50	27	140,000	41	4	129	286
IHR-F75	75	41	175,000	51	5	135	298
IHR-F-DS	N/A	N/A	N/A	N/A	N/A	86	190
IHR-F-DS-75	N/A	N/A	N/A	N/A	N/A	91	200

MODEL	FRYING AREA	DIMENSIONS	CRATED DIMENSIONS
IHR-F2525	2 EA. 6-3/4" X 14" (171 X 356 MM)	15-1/2" W X 40-3/4" D X 46-1/2" H (394 X 1035 X 1181 MM)	18" W X 43" D X 35" H (457 X 1092 X 889 MM)
IHR-F50	14" X 14" (356 X 356 MM)	15-1/2" W X 40-3/4" D X 46-1/2" H (394 X 1035 X 1181 MM)	18" W X 43" D X 35" H (457 X 1092 X 889 MM)
IHR-F75	18" X 18" 457 X 457 MM)	19-1/2" W X 40-3/4" D X 46-1/2" H (495 X 1035 X 1181 MM)	23" W X 43" D X 35" H (584 X 1092 X 889 MM)
IHR-F-DS	N/A	15-1/2" W X 40-3/4" D X 46-1/2" H (394 X 1035 X 1181 MM)	18" W X 43" D X 35" H (457 X 1092 X 889 MM)
IHR-F-DS-75	N/A	19-1/2" W X 40-3/4" D X 46-1/2" H (495 X 1035 X 1181 MM)	23" W X 43" D X 35" H (584 X 1092 X 889 MM)

Notes:

DS* specifies 4" (102 mm) deep top draining station with storage cabinet, no filter.
Includes a 4" (102 mm) deep stainless steel drain pan
Measurements in () are metric equivalents.

OPTIONS AND ACCESSORIES

- Heavy duty stainless steel backguards
- Stainless steel common front landing ledge 54", 72", 90", 108" (1372, 1829, 2286, 2743 mm)
- Fryer drain station with storage cabinet
- Automatic basket lifts
- Computer controls
- Manual timer
- Extra fry baskets with vinyl coated handles
- Gas pressure regulator, 3/4" or 1-1/4", N.P.T.
- Quick disconnect and flexible gas hose, 3/4" or 1-1/4", N.P.T.
- 3/4" rear gas connection for single unit connection
- 1-1/4" rear gas connection for single unit connection
- Gas pressure regulator, 3/4" or 1-1/4", N.P.T. connection
- Quick disconnect and flexible gas hose, 3/4" or 1-1/4", N.P.T.N.P.T.nection
- 6" (152 mm) casters or 1-1/4"

MANIFOLD PRESSURE		
NATURAL GAS	PROPANE GAS	MANIFOLD SIZE
4.0" W.C.	11.0" W.C.	1-1/4"

CLEARANCE REQUIREMENTS

For use only on non-combustible floors. Legs or casters are required for non-combustible floors; or 2" (51 mm) overhang is required when curb mounted. Provide 0" clearance from non-combustible surfaces and 8" (203 mm) from combustible surfaces.

