



GAS

SPEC SERIES | GRIDDLE TOPS

IMPERIAL



IHR-GT36-C

Shown with optional casters

Model Numbers

IHR-G36	IHR-G36-XB
IHR-GT36	IHR-GT36-XB
IHR-G36-C	IHR-G36-M
IHR-GT36-C	IHR-GT36-M

GRIDDLE TOPS

- Highly polished griddle plate provide even heat across entire surface
- "U" shaped burners have 30,000 (9 kw) BTU output, located every 12" (305mm) with one control per burner
- Aeration baffles between burners for quick recovery
- Manual or Thermostatic (GT36) controls are available
- 4" (102mm) wide grease gutter and large grease can with 1-gallon (3.8 L) capacity

STANDARD OVEN

- 40,000 BTU/hr (12KW) oven with 100% safety pilot and manual shut off valve
- Unique burner baffle distributes heat flow to provide even temperatures throughout the oven cavity
- Exclusive heat deflector reflects heat into the oven, not the floor
- Chef Depth interior is 26 ½" W x 26" D x 14" H (673 x 660 x 356 mm) and accommodates 18" x 26" (457 x 660) sheet pans left-to-right and front-to-back
- Porcelainized sides, rear, deck and door lining for easy cleaning.
- Superior heavy-duty door hinge
- Side oven controls are protected in the cool zone
- One chrome oven rack is included.
- Optional stainless steel oven interior
- Optional high mass oven with cast iron oven interior and 650 degree thermostat

CONVECTION OVEN

- 35,000 BTU/hr (1KW) Convection oven with ½ HP blower motor cooks products quickly and evenly with less shrinkage
- Electronic ignition system with Radiant solenoid valves
- Convection oven interior dimensions 26 ½" W x 22 ½" D x 14" H (673 x 572 x 356 mm)
- Three positions switch for cooking or cool down. Fan shuts off automatically when the door is open
- Porcelainized sides, rear, deck and inner door liner for easy cleaning. Stainless steel door gasket
- Burner "ON" indicator light and one hour electronic timer
- Three chrome oven racks are included.



1" (25) THICK STEEL POLISHED PLATE



GAS

SPEC SERIES | GRIDDLE TOPS

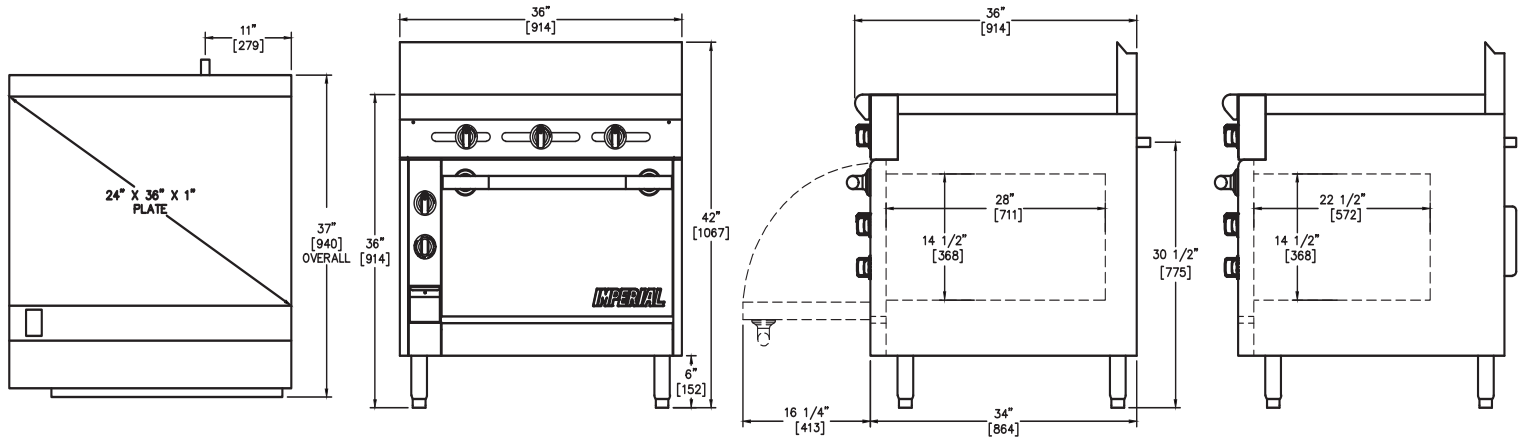

36" GRIDDLE TOP WITH MANUAL CONTROLS

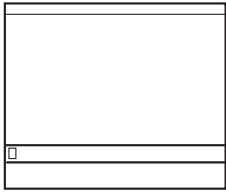

MODEL	GAS OUTPUT		GRIDDLE TOP DIMENSIONS	SHIP WEIGHT	
	BTU	KW		KG	LBS
IHR-G36	130,000	38	36"W X 24"D 914W X 610D MM	345	760
IHR-G36-C	125,000	37	36"W X 24"D 914W X 610D MM	372	820
IHR-G36-XB	90,000	26	36"W X 24"D 914W X 610D MM	268	590
IHR-G36-M	90,000	26	36"W X 24"D 914W X 610D MM	189	415

36" GRIDDLE TOP WITH THERMOSTATS

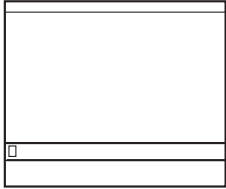

MODEL	GAS OUTPUT		GRIDDLE TOP DIMENSIONS	SHIP WEIGHT	
	BTU	KW		KG	LBS
IHR-GT36	130,000	38	36"W X 24"D 914W X 610D MM	345	760
IHR-GT36-C	125,000	37	36"W X 24"D 914W X 610D MM	372	820
IHR-GT36-XB	90,000	26	36"W X 24"D 914W X 610D MM	268	590
IHR-GT36-M	90,000	26	36"W X 24"D 914W X 610D MM	189	415

EXTERIOR

- Sleek European styling with wide radius ledge and optional high shelf
- Stainless steel front, sides, backguard, shelf, landing ledge and kick plate
- Welded and polished stainless steel seams
- Enclosed front 1-1/4" (32 mm) manifold
- Common ledges, backguards and shelves are available as options for a seamless, professional look
- Large 5" (127 mm) stainless steel landing ledge
- Unique cast aluminum control knobs feature a heat protection grip
- 6" (152 mm) high 2-1/2" (64 mm) diameter heavy duty legs with adjustable feet
- One year parts and labor warranty

OPTIONS AND ACCESSORIES

- Heavy duty stainless steel backguards
- Salamander or Cheesemelter Infra-red Broilers
- Reinforcement channels for mounting cheesemelter/salamander
- Stainless steel common front landing ledge 54", 72", 90", 108" (1372, 1829, 2286, 2743 mm)
- Chrome and Grooved griddle tops
- Stainless steel interior and double doors on open cabinet base
- Stainless steel center shelf in open cabinet base
- Extra chrome racks
- 3/4" rear gas connection for single unit connection
- 1-1/4" rear gas connection batteries up to 600,000 BTU (176 KW)
- Gas shut off valve, 3/4" or 1-1/4", N.P.T.
- Gas pressure regulator, 3/4" or 1-1/4", N.P.T.
- Quick disconnect and flexible gas hose, 3/4" or 1-1/4", N.P.T.
- 6" (152 mm) casters

MANIFOLD PRESSURE		
NATURAL GAS	PROPANE GAS	MANIFOLD SIZE
5.0" W.C.	10.0" W.C.	3/4" (19 MM)

CONVECTION OVEN ELECTRICAL REQUIREMENT		
VOLTAGE	PHASE	AMPS
120	1	6

CLEARANCE REQUIREMENTS

For use only on non-combustible floors. Legs or casters are required for non-combustible floors; or 2" (51 mm) overhang is required when curb mounted. Provide 0" clearance from non-combustible surfaces and 8" (203 mm) from combustible surfaces.

Dimensions:

36" w x 38" d x 36" h* (914 x 965 x 914 mm)

* to cooktop

Crated Dimensions:

39-1/2" w x 41" d x 35" h (1003 x 1041 x 889 mm)

Measurements in () are metric equivalents.

Notes:

- "C" specifies (1) 26-1/2" (673 mm) Convection Oven
- "M" specifies Modular, Counter Top Model
- "G" specifies Griddle Top with Manual Controls
- "GT" specifies Griddle Top with Thermostatic Controls
- "XB" specifies (1) Cabinet Base

