



GAS

SPEC SERIES | ADD-A-UNIT MODULAR MODELS

IMPERIAL



IHR-4-M

Model Numbers

IHR-2-12-M	IHR-2-18-M
IHR-4-M	IHR-1HT-12-M
HR-1HT-18-M	IHR-2HT-24-M
IHR-G12-M	IHR-G18-M
IHR-G24-M	IHR-GT12-M
IHR-GT18-M	IHR-GT24-M

ADD-A-UNITS

- Both floor model (-XB) and modular/countertop (-M) styles are available
- 12", 18", 24" (305, 457, 610 mm) wide models are available
- Common front landing ledges are available as an option with both styles to create a seamless line-up
- Floor model has an open cabinet base. Modular units are features on separate specification sheet

OPEN BURNERS

- Anti-clogging burner
- 35,000 BTU/hr (10 KW) output with 7,000 BTU/hr low simmer feature.
- One piece Venturi base has no gaskets. Venturi slopes down to the burner creating more efficient heating
- Cast-Iron burners remove and separate for cleaning
- All stainless-steel tubing and solid brass components for a long service life

GRATES

- Wavy grates create more heat transfer. Heat convects in waves for continual heat-to-pan contact
- Grates measure 12" x 14" (305 x 356 mm) or 18" x 14" (457 x 356 mm) depending on model.
- Cast iron design features flame shaping center bowl for more efficient heat transfer
- Anti-Clogging shield design into the grate protects the pilot from grease and debris

GRIDDLE TOPS

- Highly polished griddle plate provide even heat across entire surface
- "U" shaped burners have 30,000 (9 kw) BTU output, located every 12" (305mm) with one control per burner
- Aeration baffles between burners for quick recovery
- Manual or Thermostatic (GT36) controls are available
- 4" (102mm) wide grease gutter and large grease can with 1-gallon (3.8 L) capacity

HOT TOPS

- Heavy duty, highly polished plates provide an even heat across entire hot top surface
- 12" (305mm) unit has one 12" W x 28" D (305 x 711 mm) plate, 18" has one 18" W X 28" D (457 X 711 mm) plate and 24" (610 mm) unit has two 12"W X 14" D (305 X 356 mm) is also available.
- "U" Shaped burners have 40,00(12kw) BTU output. Aeration baffles between burners speed recovery time



GAS

SPEC SERIES | ADD-A-UNIT MODULAR MODELS

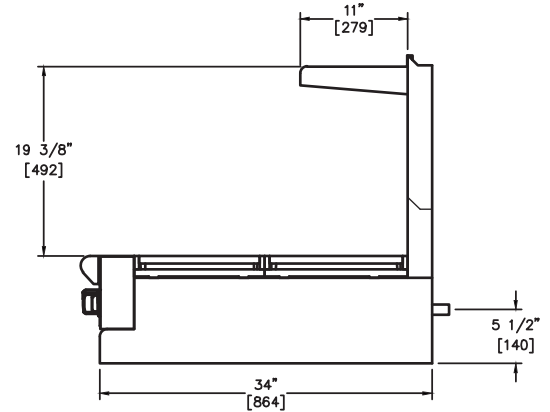
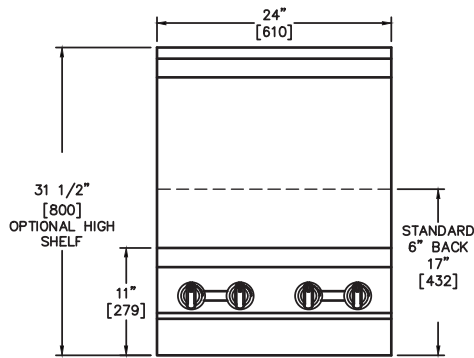
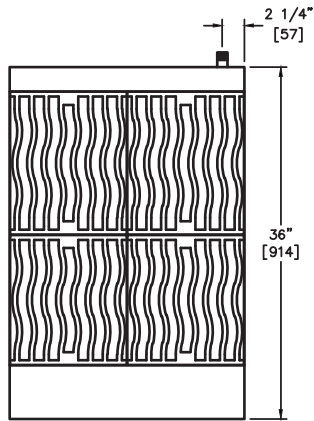

35,000 BTU (10 KW) OPEN BURNERS

MODEL	WIDTH	GAS OUTPUT		BURNERS	SHIP WEIGHT	
		BTU	KW		KG	LBS
IHR-2-12-M	12" (305 MM)	70,000	20	2	84	185
IHR-2-18-M	18" (457 MM)	70,000	20	2	71	156
IHR-4-24-M	24" (610 MM)	140,000	41	4	136	300

30,000 BTU (10 KW) AND 40,000 BTU (12 KW) HOT TOPS

MODEL	WIDTH	GAS OUTPUT		BURNERS	SHIP WEIGHT	
		BTU	KW		KG	LBS
IHR-1HT-12-M	12" (305 MM)	30,000	9	1	70	155
IHR-1HT-18-M	18" (457 MM)	40,000	12	1	94	206
IHR-2HT-24-M	24" (610 MM)	60,000	18	2	140	310

30,000 BTU (9 KW) GRIDDLE TOPS

MODEL	WIDTH	GAS OUTPUT		BURNERS	SHIP WEIGHT	
		BTU	KW		KG	LBS
IHR-G12-M	12" (305 MM)	30,000	9	1	84	185
IHR-G18-M	18" (457 MM)	40,000	12	1	110	242
IHR-G24-M	24" (610 MM)	60,000	18	2	138	305

30,000 BTU (9 KW) GRIDDLE TOPS with THERMOSTAT

MODEL	WIDTH	GAS OUTPUT		BURNERS	SHIP WEIGHT	
		BTU	KW		KG	LBS
IHR-GT12-M	12" (305 MM)	30,000	9	1	72	160
IHR-GT18-M	18" (457 MM)	40,000	12	1	110	242
IHR-GT24-M	24" (610 MM)	60,000	18	2	138	305

WIDTH	DIMENSIONS	CRATED DIMENSIONS
12" (305 MM)	12" W X 38" D X 11" H* (305 X 965 X 279 MM)	14-1/2" W X 41" D X 17" H (356 X 1041 X 432 MM)
18" (457 MM)	18" W X 38" D X 11" H* (457 X 965 X 279 MM)	20-1/2" W X 41" D X 17" H (521 X 1041 X 432 MM)
24" (610 MM)	24" W X 38" D X 11" H* (610 X 965 X 279 MM)	26-1/2" W X 41" D X 17" H (673 X 1041 X 432 MM)

MANIFOLD PRESSURE		
NATURAL GAS	PROPANE GAS	MANIFOLD SIZE
5.0" W.C.	10.0" W.C.	3/4" (19 MM)

EXTERIOR

- Sleek European styling with wide radius ledge and optional high shelf
- Stainless steel front, sides, backguard, shelf, landing ledge and kick plate
- Enclosed front 1-1/4" (32 mm) manifold
- Large 7" (178 mm) stainless steel landing ledge
- Unique cast aluminum control knobs feature a heat protection grip
- Full width, removable crumb tray for easy cleaning
- One year parts and labor warranty

OPTIONS AND ACCESSORIES

- Heavy duty stainless steel backguards
- Stainless steel common front landing ledge 54", 72", 90", 108" (1372, 1829, 2286, 2743 mm)
- Stainless steel 10" (245 mm) wok ring, fits over open burner top grate
- 3/4" rear gas connection for single unit connection
- 1-1/4" rear gas connection batteries up to 600,000 BTU (176 KW)
- Gas shut off valve, 3/4" or 1-1/4", N.P.T.
- Gas pressure regulator, 3/4" or 1-1/4", N.P.T.
- Quick disconnect and flexible gas hose, 3/4" or 1-1/4", N.P.T.
- Stainless steel equipment stands
- 6" (152 mm) casters for stainless steel stand
- Refrigerated bases 36" and 72" wide (914 and 1829 mm)

CLEARANCE REQUIREMENTS

For use only on non-combustible surfaces. Provide 0" clearance from non-combustible surfaces and 6" (152 mm) from combustible surfaces.

