



**GAS**

SPEC SERIES | PLANCHA TOP

**IMPERIAL**



## IHR-36PL-C

Shown with optional casters

Model Numbers

IHR-PL36 IHR-PL36-XB

IHR-PL36-C IHR-PL36-M

## PLANCHA TOP

- ½" (8mm) thick polished steel griddle plate
- Griddle plate is 28" (711mm) wide and 22 ½" (57 mm) deep
- Quick heat-up time

## STANDARD OVEN

- 40,000 BTU/hr (12KW) oven with 100% safety pilot and manual shut off valve
- Unique burner baffle distributes heat flow to provide even temperatures throughout the oven cavity
- Exclusive heat deflector reflects heat into the oven, not the floor
- Chef Depth interior is 26 ½" W x 26" D x 14" H (673 x 660 x 356 mm) and accommodates 18" x 26" (457 x 660) sheet pans left-to-right and front-to-back
- Porcelainized sides, rear, deck and door lining for easy cleaning.
- Superior heavy-duty door hinge
- Side oven controls are protected in the cool zone
- One chrome oven rack is included.
- Optional stainless steel oven interior
- Optional high mass oven with cast iron oven interior and 650 degree thermostat

## CONVECTION OVEN

- 35,000 BTU/hr (1KW) Convection oven with ½ HP blower motor cooks products quickly and evenly with less shrinkage
- Electronic ignition system with Radiant solenoid valves
- Convection oven interior dimensions 26 ½" W x 22 ½" D x 14" H (673 x 572 x 356 mm)
- Three positions switch for cooking or cool down. Fan shuts off automatically when the door is open
- Porcelainized sides, rear, deck and inner door liner for easy cleaning. Stainless steel door gasket
- Burner "ON" indicator light and one hour electronic timer
- Three chrome oven racks are included.



"M" SHAPED BURNER FOR EVEN HEATING THROUGH-OUT THE OVEN CAVITY.



PLANCHA TOP SHOWN WITH OPTIONAL CUT-OUTS FOR FOOD PANS.



ACCOMMODATE SHEET PANS FRONT-TO-BACK AND SIDE-TO-SIDE.



# GAS

## SPEC SERIES | PLANCHA TOP

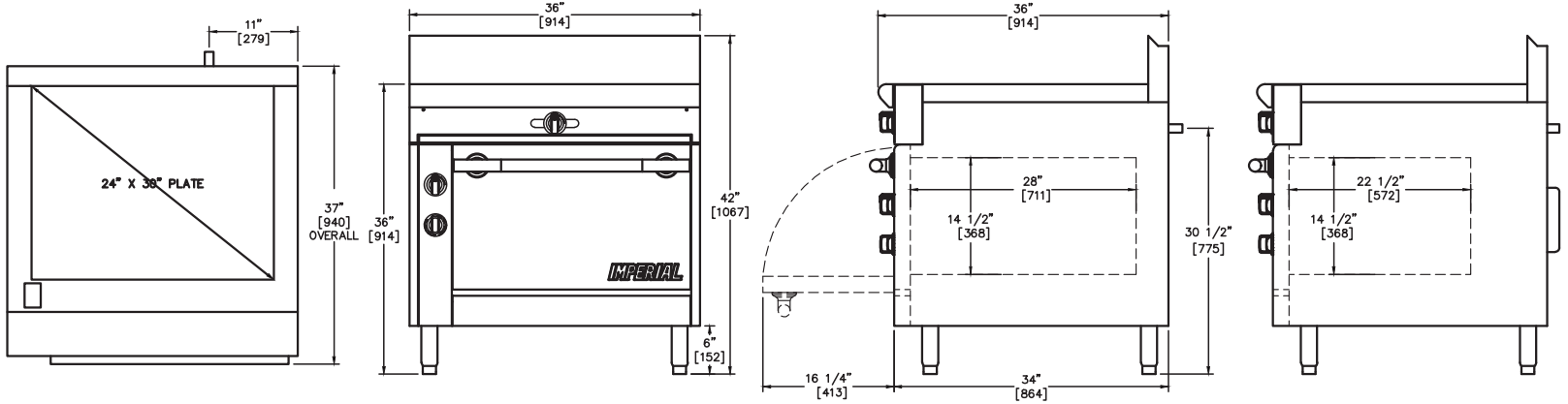

### 36" PLANCHA GRIDDLE TOP WITH MANUAL CONTROLS

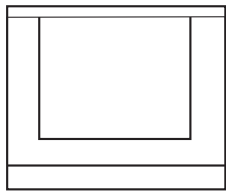

MODEL	GAS OUTPUT		PLANCHA WIDTH	PLANCHA DEPTH	SHIP WEIGHT	
	BTU	KW			KG	LBS
IHR-PL36	70,000	21	28" (711 MM)	22-1/2" (571 MM)	275	605
IHR-PL36-C	65,000	19	28" (711 MM)	22-1/2" (571 MM)	303	668
IHR-PL36-XB	30,000	9	28" (711 MM)	22-1/2" (571 MM)	217	478
IHR-PL36-M	30,000	9	28" (711 MM)	22-1/2" (571 MM)	160	352

MANIFOLD PRESSURE		
NATURAL GAS	PROPANE GAS	MANIFOLD SIZE
5.0" W.C.	10.0" W.C.	3/4" (19 MM)

### CLEARANCE REQUIREMENTS

For use only on non-combustible floors. Legs or casters are required for non-combustible floors; or 2" (51 mm) overhang is required when curb mounted. Provide 0" clearance from non-combustible surfaces and 8" (203 mm) from combustible surfaces.

### EXTERIOR

- Sleek European styling with wide radius ledge and optional high shelf
- Stainless steel front, sides, backguard, shelf, landing ledge and kick plate
- Welded and polished stainless steel seams
- Enclosed front 1-1/4" (32 mm) manifold
- Common ledges, backguards and shelves are available as options for a seamless, professional look
- Large 5" (127 mm) stainless steel landing ledge  
Unique cast aluminum control knobs feature a heat protection grip
- 6" (152 mm) high 2-1/2" (64 mm) diameter heavy duty legs with adjustable feet
- One year parts and labor warranty

### Notes:

"C" specifies (1) 26-1/2" (673 mm) Convection Oven  
 "XB" specifies (1) Cabinet Base  
 "M" specifies Modular, Counter Top Model  
 "PL" specifies Plancha Top

### Dimensions:

36" w x 38" d x 36" h\* (914 x 965 x 914 mm)

\* to cooktop

### Crated Dimensions:

39-1/2" w x 41" d x 35" h (1003 x 1041 x 889 mm)



### OPTIONS AND ACCESSORIES

- Heavy duty stainless steel backguards
- Salamander or Cheesemelter Infra-red Broilers
- Reinforcement channels for mounting cheesemelter/salamander
- Landing ledge cut-outs for inserting food pans
- Extra chrome racks
- Refrigerated bases 36" and 72" wide (914 and 1829 mm)
- Stainless steel common front landing ledge 54", 72", 90", 108" (1372, 1829, 2286, 2743 mm)
- Stainless steel interior and double doors on open cabinet base
- Stainless steel center shelf in open cabinet base
- 3/4" rear gas connection for single unit connection
- 1-1/4" rear gas connection batteries up to 600,000 BTU (176 KW)
- Gas shut off valve, 3/4" or 1-1/4", N.P.T.
- Gas pressure regulator, 3/4" or 1-1/4", N.P.T.
- Quick disconnect and flexible gas hose, 3/4" or 1-1/4", N.P.T.
- Stainless steel equipment stand for modular unit
- 6" (152 mm) casters for stainless steel stand
- 6" (152 mm) casters