

## SINGLE ELECTRIC BOILERLESS CONVECTION STEAMER



Altair II - 4



Altair II - 6

- Altair II - 4 - four pan electric countertop boilerless steamer
- Altair II - 6 - six pan electric countertop boilerless steamer

### STANDARD FEATURES:

#### Controls:

- 4-Position cooking mode selector: OFF and 3 mode steaming - soft poach, traditional steam, high heat steam: or can be set to custom specifications up to 230°F (110°C)
- Pulls out for easy service access
- Clean Probe Indicator Light
- Heating Indicator Light
- 60-Minute Timer

#### Construction:

- 304 Stainless, #4 Finish (Cabinet)
- 356 Aluminum Cast Cooking Compartment with Hard-Anodized Finish

#### Other:

- Energy Star Compliant
- Manual Front Drain Valve
- Internally Preheated Incoming Water for Quick Recovery
- Clean Water Reservoir System Keeps Food Out of the Water
- Condensate Trough Plumbed to Drain at Rear
- Redundant Safety Systems
- One-Year Parts and Service

#### Doors:

- The door is insulated.
- Safety shut-offs are provided by a hidden magnetic door switch, low water/high limit heat switch, temperature probe, water sensing probe and water-fill timer.

### OPTIONS & ACCESSORIES AT ADDITIONAL COST

#### Pans & Covers

- 12" x 20" pan cover
- 12" x 20" x 1" solid pan
- 12" x 20" x 1" perforated pan
- 12" x 20" x 2-1/2" solid pan
- 12" x 20" x 2-1/2" perforated pan
- 12" x 20" x 4" solid pan
- 12" x 20" x 4" perforated pan

- 12" x 20" x 6" solid pan
- 12" x 20" x 6" perforated pan

#### Stands, Racks & Casters

- MSS - 34.5" tall mobile stand w/slide out shelf and under shelf
- SSS - 29.75" tall stationary stand w/slide out shelf and under shelf
- STSS - 12" tall stationary stand (Altair II-6 only)
- STSM - 16-5/8" tall mobile stand (Altair II-6 only)

- Pan rack assembly for MSS and SSS
- Set of 4 casters, 2 with brakes
- Prison package, includes lockable stainless steel hinged control cover, tamper proof screws, (2) 4" adjustable front flanged feet
- Heat and water side shield
- Vega condenser hood with hose
- Water hose kit - 60" line with quick disconnect

### STANDARD CONSTRUCTION SPECIFICATIONS

Altair II is a Market Forge convection/circulating boilerless steam oven with automatic water-fill, featuring internally preheated water for fast recovery, clean water reservoir system, and rear drain.

Altair II models are efficiently heated by electrical elements external to the water reservoir.

Four-pan steamers have 8 kW; six-pan steamers have 9.8 kW per compartment.

Operation occurs from steam generated in the cooking compartment.

The steamer cavity has a convection fan that increases steam velocity and provides efficient steam distribution throughout the cavity.

Cooking compartment is constructed of cast aluminum with a food-grade non-stick hard anodized finish.

The cooking compartment acts as a heat sink, allowing for heat retention, quick recovery, and reduced energy consumption.



Approval Notes: \_\_\_\_\_

\_\_\_\_\_

ALTAIR II SINGLE

DIMENSIONS ARE IN INCHES [MM]

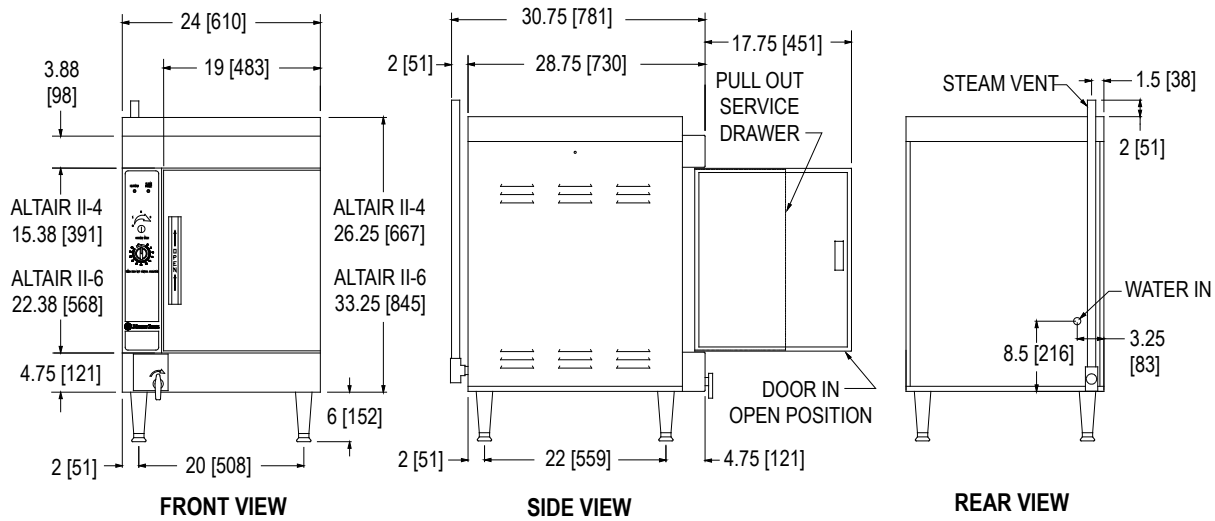

The manufacturer reserves the right to modify materials and specifications without notice.

**ELECTRICAL CHARACTERISTICS**

ELECTRICAL (ALTAIR II - 4) 60 Hz			
Voltage	pH	kW	Amps
208	1	8	38.5
240	1	8	33.3
208	3	8	22.2
240	3	8	19.3
480	3	8	9.6

ELECTRICAL (ALTAIR II - 6) 60 Hz			
Voltage	pH	kW	Amps
208	1	9.8	47.1
240	1	9.8	40.8
208	3	9.8	27.2
240	3	9.8	23.6
480	3	9.8	11.8

**COMPARTMENT PAN CAPACITY AND WEIGHT INFORMATION**

Pans	Altair II-4	Altair II-6
12" x 20" x 1"	8	12
12" x 20" x 2-1/2"	4	6
12" x 20" x 4"	2	4
12" x 20" x 6"	1	2

MODEL	SHIPPING WEIGHT
Altair II - 4	225 lbs (102 kg)
Altair II - 6	250 lbs (113 kg)

**WATER SUPPLY AND DRAIN SPECIFICATIONS**

Good quality water feed is the responsibility of the owner. Water quality must be within the following general guidelines.

TDS: 40-125 ppm    Hardness: 35-100 ppm    pH: 7.0 - 8.5    Silica: <13 ppm    Chlorides: <25 ppm    Chlorine: <0.2 ppm    Chloramine: <0.2 ppm

The best defense against poor water quality is a water treatment system designed to meet your water quality conditions.

Pressure: 25(min)-50(max) PSI    Connections: Trough drain: 1/2 MNTP    Drain out: 1" FNPT    Water: 3/4" male garden hose

Appliance to be installed with backflow protection according to federal, state or local codes.

The drain piping must consist of temperature resistant material, greater than 160°F, and be of adequate diameter not to cause flow restriction. Improper materials may deform and cause restrictions, thus affecting performance.

**NOTES**

- Each single compartment has one rear drain connection
- 4" clearance left mandatory, right and rear is recommended.
- Location near a floor drain is recommended.
- Refer to electrical characteristics chart for voltage requirements of each steamer.
- Each compartment requires separate electrical & water connection.

**DISCLAIMER**

**Terry System Cartridge Changes / Installation** – "2-3 gallons of water MUST be purged at each cartridge change or new installation prior to water supply being fed to the steamer. Failure to do so can result in component damage within the steamer which is not covered under warranty. For additional guidance on proper installation, refer to install documentation provided with each Terry System and Replacement Cartridge Set."

**INTENDED FOR COMMERCIAL USE ONLY.  
NOT FOR HOUSEHOLD USE.**

