



Job _____ Item No. _____

Star® Radiant Compact Conveyor Toasters

☐RCS2-600BN ☐RCS2-600N



RCS2-600BN

FEATURES

- High volume compact toaster with 5" wide stainless steel belt requires only 9.5" width of counter space
- Forced convection system keeps the toaster cool-to-the-touch and increases productivity by circulating pre-heated air into toasting chamber
- Incoloy metal sheath elements provide fast, consistent heating. Top-side toasting for bagel toaster, and dual-sided toasting for bread
- Long lasting, heavy-duty metal knobs, 1" non-skid heavy-duty rubber feet, and extended conveyor belt with full-width burn guard
- Simple analog belt speed control and heated holding area to keep toast at the perfect temperature
- Hi-limit switch prevents toaster from overheating protecting critical component parts
- 120V - plugs in anywhere

DESCRIPTION

The RCS2 Series is the name in compact bagel productivity. At only 9.5" overall width it can fit ANYWHERE, and the 5" wide belt can process 600 bagel slices/hr or 400 bread slices/hr. The 120V utility and compact size mean this unit is perfect for satellite locations - next to the drive-thru, near the register - whatever your needs.

SPECIFICATIONS

High performance conveyor toaster is constructed of corrosion resistant stainless steel. Supplied with heavy-duty motor, drive chain and metal sheath elements. A conveyor belt tension system is supplied for a smooth, quiet operation. Extended conveyor belt, crumb tray, heated holding area and full width burn guard is standard. Unit has a one-piece cover for easy access with 1" adjustable legs and a 5ft minimum cord length.

WARRANTY

These units come with a one [1] year warranty for parts and labor.

TOASTING CAPACITY

MODEL	DESCRIPTION	SLICES PER HOUR
RCS2-600BN	1.75" Opening COMPACT BAGEL TOASTER	600
RCS2-600N	1.75" Opening COMPACT TOASTER	400

CERTIFICATIONS



STAR MANUFACTURING INTERNATIONAL INC.

265 Hobson St. • Smithville, TN 37166
 Telephone 800 264 7827 • Fax 314 781 5445
 www.star-mfg.com

Printed in the U.S.A. • 2M-Z22826 • Rev A • 10.2018
 Specifications are subject to change without notice and are not intended for installation purposes.



Star® Radiant Compact Conveyor Toasters

□RCS2-600BN □RCS2-600N

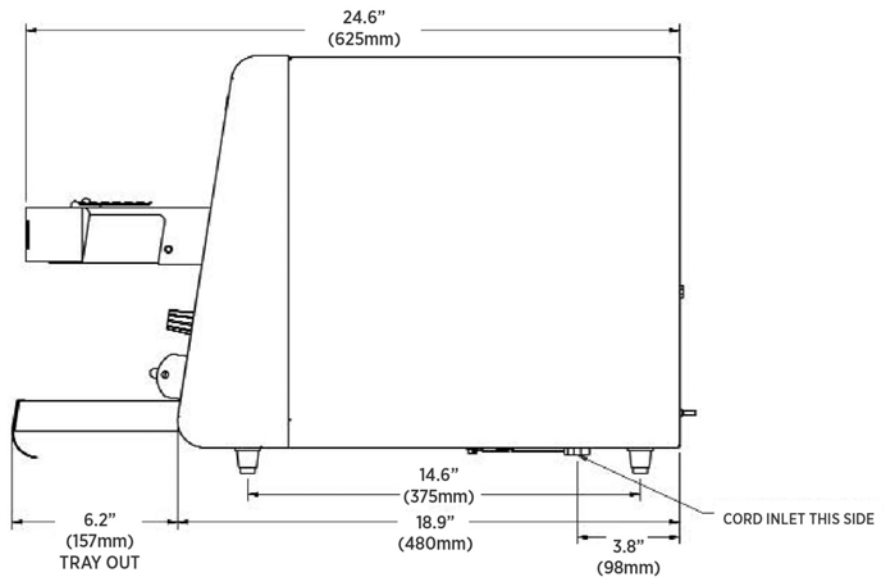
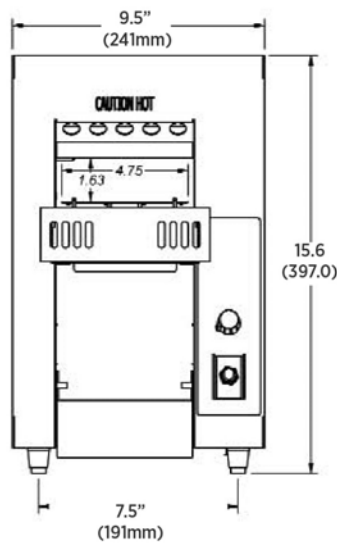
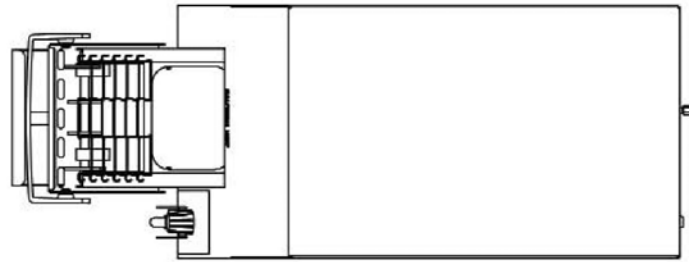

MODEL	DESCRIPTION	SLICES PER HOUR	HEIGHT in. (mm)	WIDTH in. (mm)	DEPTH in. (mm)	VOLTS1	AMPS	WATTS	NEMA PLUG	APPROX. SHIP WEIGHT
RCS2-600BN	1.75" Opening COMPACT BAGEL TOASTER	600	15.6 (397)	9.5 (241)	24.6 (625)	120V	12	1,440	5-15P	58 lb. (26 kg)
RCS2-600N	1.75" Opening COMPACT TOASTER	400	15.6 (397)	9.5 (241)	24.6 (625)	120V	12	1,440	5-15P	58 lb. (26 kg)



5-15P

Due to periodic changes in designs, methods, procedures, policies and regulations, the specifications contained in this sheet are subject to change without notice. While Star Manufacturing exercises good faith efforts to provide information that is accurate, we are not responsible for errors or omissions in information provided or conclusions reached as a result of using the specifications. By using the information provided, the user assumes all risks in connection with such use.



STAR MANUFACTURING INTERNATIONAL INC.

265 Hobson St. • Smithville, TN 37166
 Telephone 800 264 7827 • Fax 314 781 5445
www.star-mfg.com

Printed in the U.S.A. • 2M-Z22826 • Rev A • 10.2018
 Specifications are subject to change without notice and are not intended for installation purposes.