

V-Series 100 Qt. Mixer

The kitchen workhorse, for a wide range of heavy-duty mixing applications.



MODELS

- V100PL** 100 qt. Power Lift Mixer

STANDARD FEATURES

- Stainless steel top cover, planetary cover, bayonet shaft, bowl guard and legs
- IP32 rated
- Powerful 4 HP motor with variable speed drive and agitator speed range from 47 RPMs to 257 RPMs
- No bowl adapters required for down-sizing bowls
- Front-mounted controls with 90-minute digital timer, power bowl lift and emergency stop
- Durable powder coated finish on legs and outer surfaces not constructed of stainless steel
- High torque transmission
- Permanently lubricated planetary head & attachment hub case
- Bowl scraper bracket affixes to planetary head
- Grease lubricated, anti-friction ball bearings
- Patent-pending interlock prevents operation if guard is opened or bowl is lowered
- Overload protection and no volt release
- Non-skid rubber feet
- 6 foot cord
- ETL and NSF listed
- Made in Denmark

STANDARD ACCESSORIES

- **VBOWL-100** – Stainless steel bowl
- **VBEAT-100A** – Aluminum flat beater
- **VWHIP-100** – Stainless steel wire whip
- **VHOOK-100** – Stainless steel dough hook
- **VCHUTE** – Stainless steel ingredient chute

WARRANTY

- **NEW!** Four-year parts & labor limited warranty

OPTIONAL ACCESSORIES/ATTACHMENTS

- 40 qt. bowl and attachments
- 60 qt. bowl and attachments
- Bowl scraper - 40 qt., 60 qt. or 100 qt. options
- Bowl Truck
- Stainless Steel and Correctional models

To select options see back



ETL listed
Conforms to UL Std 763
Certified to CSA Std C22.2 No. 195

Approved by: _____

Date: _____

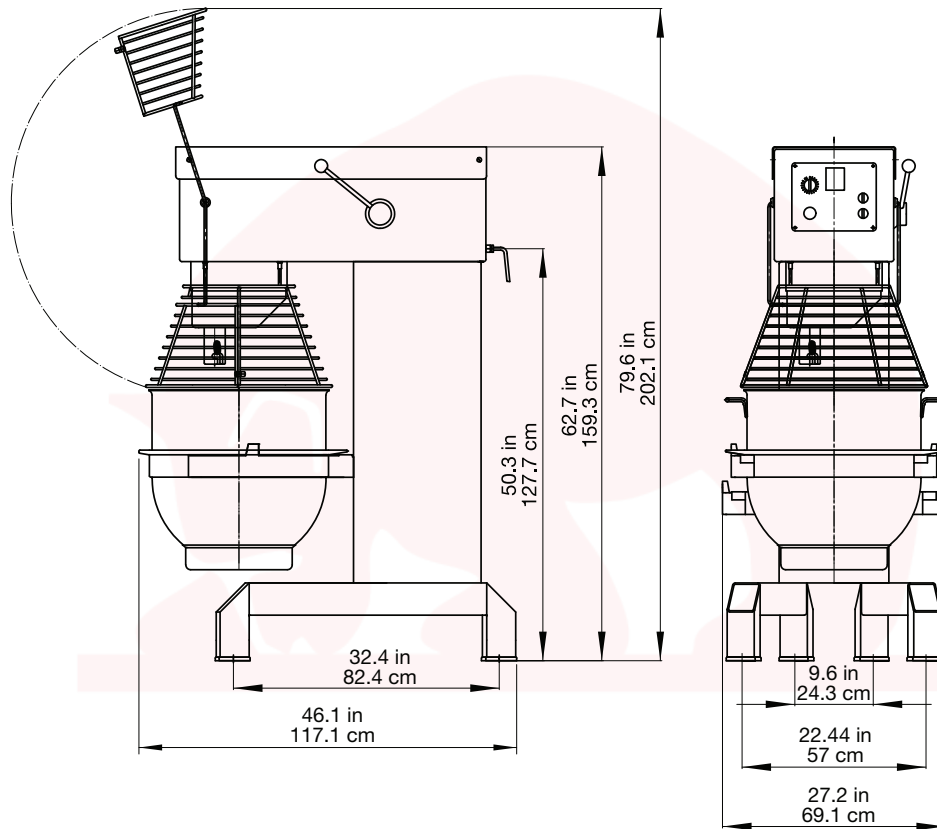

SPECIFICATIONS

Model	Motor	Volts	Amp	Plug Type	Mixing Speeds	Hub Speeds	IP Rating
V100PL	4 HP	208/60/3	13	--	47 - 257 RPMs	N/A	IP32

Delivered without plug. Specify voltage when ordering.

DIMENSIONS | SHIPPING INFORMATION

Reinforced carton for shipping. This product ships on a pallet. See dimensions below.

Model	Overall Dimensions	Net Wt.	Shipping Dimensions	Ship Wt.	Freight Class
V100PL	29" W x 44.5" D x 63" H (73.66 cm x 113.03 cm x 160 cm)	870 lbs. (395 kg)	33" W x 49" D x 78" H (83.82 cm x 124.4 cm x 198.12 cm)	981 lbs. (444.97 kg)	85 73 CU ft.

OPTIONAL/ADDITIONAL ACCESSORIES

- VBTRUCK-100 100 qt. bowl truck
- VBTRUCK60-100 60 qt. bowl truck
- VBTRUCK40-100 40 qt. bowl truck
- VBOWL40-100 40 qt. bowl
- VBOWL60-100 60 qt. bowl
- VBEAT-100SS 100 qt. SST beater
- VACC60-100 60 qt. adapter kit
- VACC40-100 40 qt. adapter kit
- VSCRCP40-100 40 qt. scraper
- VSCRCP60-100 60 qt. scraper
- VSCRCP-100 100 qt. scraper
- VHOOK40-100 40 qt. hook
- VHOOK60-100 60 qt. hook
- VBEAT40-100 40 qt. beater
- VBEAT60-100 60 qt. beater
- VWHIP40-100 40 qt. standard wire whip
- VWHIP60-100 60 qt. standard wire whip
- VWINGWHIP100 100 qt. wire wing whip
- VHDWHIP-100 100 qt. heavy-duty wire whip

Product	Attachment	V100PL
Bread Dough (65% AR)	Hook	155 lbs.
Pizza Dough (50% AR)	Hook	135 lbs.
Mashed Potatoes	Whip / Beater	76 lbs.
Whipped Cream	Whip	20 qts.
Pancake Batter	Whip / Beater	44 qts.
Cookie Dough	Beater / Hook	105 lbs.

Heavy-duty 100 qt. mixer with 4 HP motor and variable speed drive with agitator speed range from 47 to 257 RPMs. Stainless steel top cover, bayonet shaft and bowl guard. Non-stainless steel surfaces powder coated finish. Front-mounted controls with power bowl lift and 90-minute digital timer. Permanently lubricated planetary head and attachment hub case. 6 ft. cord. Mixer is IP32 rated with ETL and NSF certification. Four-year parts and labor limited warranty.