



Job _____ Item No. _____

Electric Countertop Hot Plate

- Single Spiral Element H33
- Dual Spiral Element H115 H63
- Dual French Top Element H70



H63

DESCRIPTION

Wells electric countertop hot plates are designed to be dependable and easy to use. These units are a versatile solution for all sorts of operations, big or small, and take up minimal counter space. These units are a simple way to add reliable cooking power to your kitchen.

SPECIFICATIONS

Wells electric countertop hot plates are constructed with a steel body. H33, H63, and H70 units will come with 4-inch (102 mm) tall plastic legs and H115 units will come with 1-inch (25 mm) tall plastic legs. H33 and H115 units will be 120 V and will come with a factory wired cordset with a 5-15P plug. H63 and H70 models will be 208 V/240 V and will come single phase with no cordset included on standard models, and can be field converted to three phase. The H70 model will also be available as a 220 V/240 V export version. H33, H63, and H115 models will have spiral top[s]. The H70 model will have french tops.

WARRANTY

These units come with a one [1] year warranty for parts and labor.

FEATURES

H33/H115

- Spiral elements are 6 in. (152 mm) in diameter, self-cleaning, and utilize a flat element design for more surface contact.
- Removable chrome-plated drip tray for easy cleaning

H63

- Spiral elements are 8 in. (203 mm) in diameter, self-cleaning, and utilize a flat element design for more surface contact.
- Removable stainless steel drip tray for easy cleaning

H70

- French top elements are 9 in. (229 mm) in diameter to provide very even heat distribution over a large area.

All Models

- Controls have a protective guard ring to prevent accidental temperature changes
- Infinite control switch for precise adjustment of temperature

OPTIONS & ACCESSORIES

- 6-30P cordset for 208 V/240 V models [part number 20141]
- 4-inch (102 mm) tall metal legs [part number 20563]
- 1-inch (25 mm) tall plastic legs [part number 21109]

CERTIFICATIONS



¹ H70 220 V/240 V model only



WELLS MANUFACTURING • www.wells-mfg.com

265 Hobson Street • Smithville, Tennessee 37166

Telephone 888 356 5362 • Fax 314 781 5445

Printed in the U.S.A. • 2M-Z21960 • Rev A • 04.2018
Specifications are subject to change without notice and are not intended for installation purposes.



Electric Countertop Hot Plate

- Single Spiral Element □H33
- Dual Spiral Element □H115 □H63
- Dual French Top Element □H70

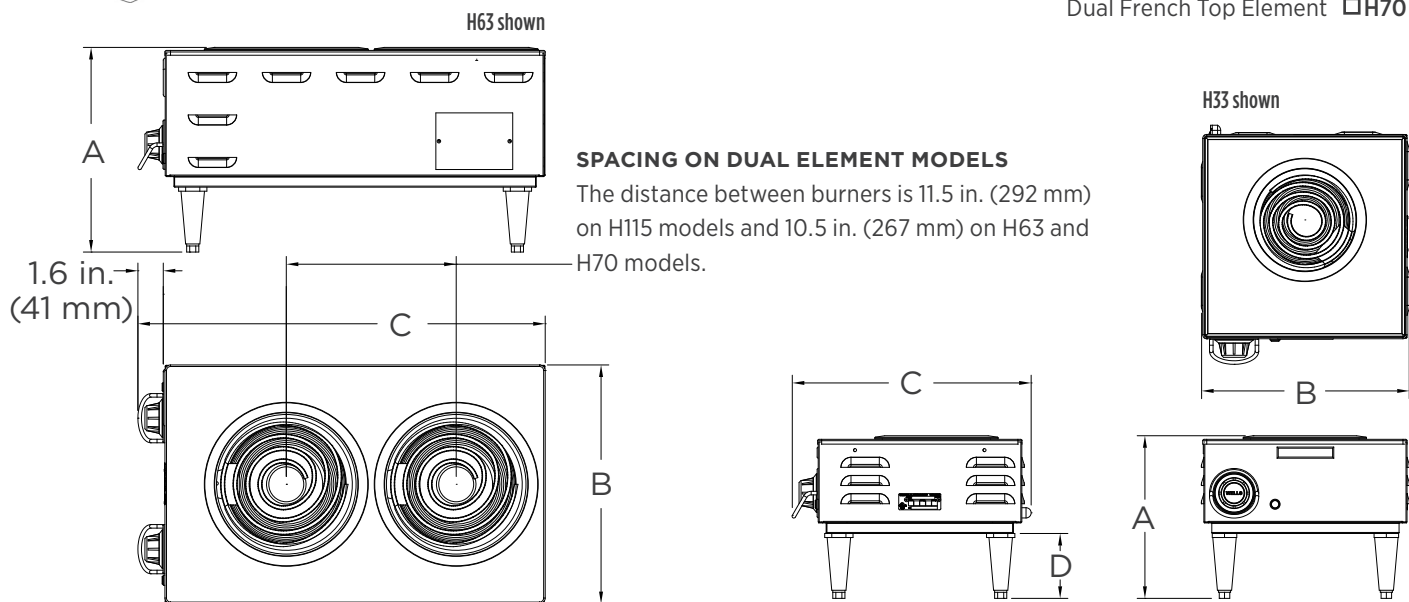

MODEL	HEIGHT [A]	WIDTH [B]	DEPTH [C]	LEG HEIGHT [D]	APPROX. SHIP WEIGHT	APPROX. WEIGHT INSTALLED
H33	10.1 in. (257 mm)	12.8 in. (325 mm)	14.8 (376 mm)	4 in. (102 mm)	14 lb. (6.4 kg)	11 lb. (5 kg)
H115	7.1 in. (180 mm)	14.75 in. (375 mm)	25.7 (653 mm)	1 in. (25 mm)	21 lb. (9.5 kg)	18 lb. (8.2 kg)
H63	12.6 (320 mm)	14.75 in. (375 mm)	25.2 (640 mm)	4 in. (102 mm)	30 lb. (13.6 kg)	26 lb. (11.8 kg)
H70	12.6 (320 mm)	14.75 in. (375 mm)	25.2 (640 mm)	4 in. (102 mm)	35 lb. (15.9 kg)	32 lb. (14.5 kg)

CLEARANCES

Allow 1 inch (25 mm) of space between both sides and back of the unit from any combustible surface and 4 inches (102 mm) of space between the bottom of the body of the unit from any combustible surface.

ELECTRICAL CONNECTION LOCATION

[from operator's perspective]

- H33**—rear of the unit, 0.75 in. (19 mm) from the left and 5.25 in. (133 mm) high
- H115**—rear of the unit, 1 in. (25 mm) from the left and 5.5 in. (140 mm) high
- H63 and H70**—knockout on rear of the unit, 1.25 in. (32 mm) from the right and 7.25 in. (184 mm) high

MODEL	VOLTS	WATTS	1 ϕ AMPS	3 ϕ [DELTA] AMPS			NEMA PLUG
				L1	L2	L3	
H33	120	1,500	12.5				5-15P
H115	120	1,650	13.8				5-15P
H63	208	3,900	18.75	16.3	9.4	9.4	NONE ²
	240	5,200	21.7	18.8	10.8	10.8	
H70	208	3,000	14.4	12.5	7.2	7.2	NONE ³
	220	3,360	15.3	13.2	7.6	7.6	
	240	4,000	16.7	14.4	8.3	8.3	

² standard version is set up to hardwire, optional version with factory attached cordset available for single phase use

³ set up to hardwire

Due to periodic changes in designs, methods, procedures, policies and regulations, the specifications contained in this sheet are subject to change without notice. While Star Manufacturing exercises good faith efforts to provide information that is accurate, we are not responsible for errors or omissions in information provided or conclusions reached as a result of using the specifications. By using the information provided, the user assumes all risks in connection with such use.



WELLS MANUFACTURING • www.wells-mfg.com
 265 Hobson Street • Smithville, Tennessee 37166
 Telephone 888 356 5362 • Fax 314 781 5445

Printed in the U.S.A. • 2M-Z21960 • Rev A • 04.2018
 Please refer to the owner's manual for information regarding installation or use.