

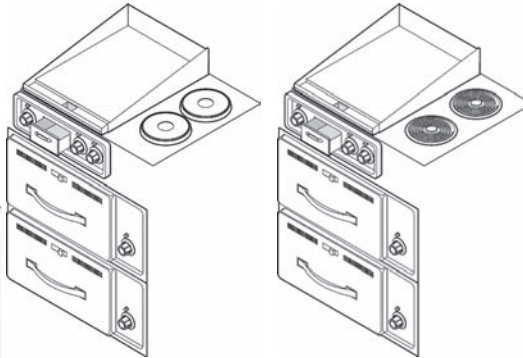

VCS 2000 - Ventless Cooking Systems Drawer Warmer Base and Combination Griddle & Hot Plate Tops

MODELS WV2HGRW WV2HSGRW

Model WV2HGRW SHOWN



Model WV2HGRW Model WV2HSGRW

DESCRIPTION

Wells Universal hoods are Certified Type-1 compliant, UL710B approved recirculation hood systems and feature completely self-contained air filtration and fire-suppression systems. They do not require venting outside making it possible to cook in non-traditional locations or when traditional Type-1 hoods and duct-work are impractical, restricted or too expensive. VCS models are integrated with hood and cooking equipment in one, ready to use package.

SPECIFICATIONS

Fire Protection – Completely self contained ANSUL® R-102 system includes ANSUL® tank, nitrogen cartridge, ANSUL® soprofanifier, piping, fusible links, ANSUL® drops, nozzles, and movable manual pull station. Manual pull can be relocated to the egress position or an additional station can be added by an authorized ANSUL® representative. Fire protection system meets NFPA 96 Chapter 13. Fire protection system must be charged and certified by ANSUL® Authorized distributor after installation and before first use (operator's responsibility).

Filtration – Completely self-contained filtration process reduces emissions below that allowed in NFPA 96 and ANSI UL710B using the EPA 202 test method. VCS includes a fully self-contained 4-stage air filtration system including a stainless steel grease baffle filter with grease cup, a fire-rated fiberglass pre-filter, a HEPA (High-Efficiency Particulate Air) filter / carbon-charcoal filter pack. All filters are easily removable with out tools. Air flow sensors continually monitor air flow optimizing performance and grease removal while an interlock system will not allow cooking appliances to function if filters are missing, clogged or in the event of a fire.

Cooking Appliances – Cooking equipment is included and integrated in all VCS models. Both the WV2HGRW and WV2HSGRW includes a world-renown Wells double-drawer warmer with individual thermostatic temperature controls. The WV2HGRW also include a heavy duty griddle and two each French style hot plates while the WV2HSGRW includes a heavy duty griddle and two each spiral style hot plates. Hot plates are independently regulated by infinite controls with positive-off positions.

Exhaust and Air Flow – Exhaust air is vertical discharge. Typical airflow is 800 CFM. A minimum of 400 cubic feet of fresh air per minute is recommended both in and out of the cooking area to ensure the dilution of cooking aromas.

STANDARD FEATURES

- Completely self-contained, 4-stage filtration system
- Completely self-contained fire protection system
- Very quiet with only 68 dBA average
- Interlock system will disable cooking appliances if filters are missing, clogged or in the event of a fire
- Airflow sensors continually monitor airflow for optimizing performance and grease removal
- Illuminated early-warning system to monitor filter replacement
- Completely self-contained filtration process reduces emissions below that allowed in NFPA 96 and ANSI UL710B using the EPA 202 test method
- Interior incandescent light in protected glass globe improves visibility
- Stainless steel construction for strength, durability and ease of cleaning
- Fits through a 36" wide door opening
- Two each adjustable 6" to 8" front legs and 2 each 6" rear mounted rigid casters standard
- VCS are movable, making them ideal for leased spaces
- Convection oven base features stainless steel exterior and interior, full-insulation, two-speed fan, ergo metric handle, five HD oven racks and solid state temperature and timer controls with five easy-to-use programmable menu keys
- Drawer warmer base features stainless steel exteriors, individual thermostatic temperature controls per drawer (adjustable from 90° to 210° F), durable stainless steel tracks and bearings, humidity control and each drawer includes a removable 12" by 20" x 6" stainless steel pan
- WV2HGRW is available in 208/240V 1Ø or 3Ø @ 8.7KW with an 18 ½" wide griddle and 2 each 9" French style hot plates elements
- WV2HSGRW is available in 208V 3Ø @ 9.6KW or 240V 3Ø @12KW with an 18 ½" wide griddle and 2 each 8" spiral style hot plates elements

OPTIONS & ACCESSORIES

- Pre filter # 22618
- HEPA/charcoal filter pack # 22619
- Rear leg kit #22649 (set of two)
- Caster set – two rigid rear casters # 22650
- Chrome plated griddle surface
- Grooved griddle surface (grooved griddle not available with chrome plating)

CERTIFICATIONS



WELLS-WV2H-04/18

**Wells Manufacturing** • 265 Hobson Street, Smithville, Tennessee 37166 U.S.A.

Phone : (314) 678-6314 • Fax (314) 781-5445

www.wells-mfg.com • Printed in the U.S.A.

Specifications are subject to change without notice and are not intended for installation purposes. See installation instructions prior to installing the unit.



VCS 2000 - Ventless Cooking Systems Drawer Warmer Base and Combination Griddle & Hot Plate Tops

MODELS □ WV2HGRW □ WV2HSGRW

DIMENSIONS: INCH
 (MM)

MINIMUM CLEARANCE REQUIRED FROM UNIT TO THE NEAREST SURFACE			
BACK NA NA	SIDE SEE REQUIRED SPACERS	BOTTOM 6 (152)	TOP 8 (203)

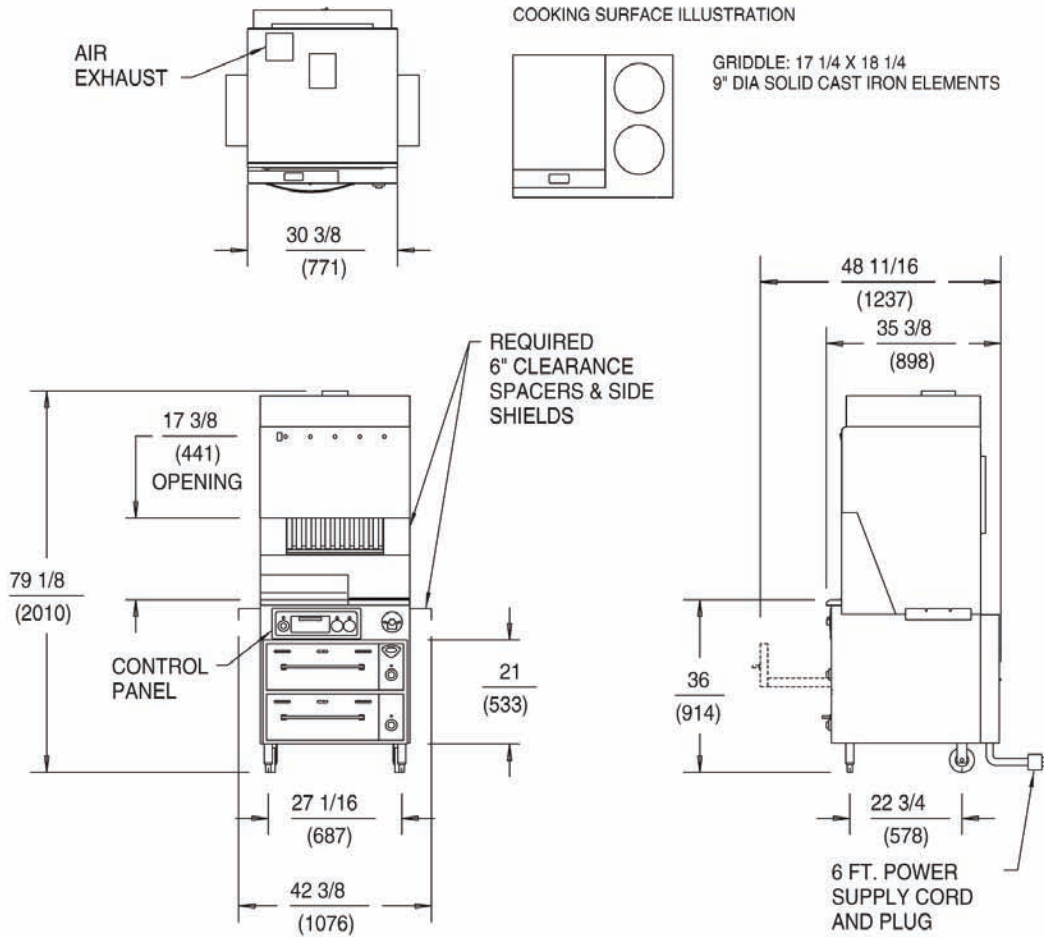

Model Number	W x D x H	Voltage & Phase	Watts	Amps Single Phase	Amps Per Line 3Phase L1 L2 L3	NEMA (3 phase only)	Weight (Shipping)
WV2HGRW	42-3/8" x 35-3/8" x 79-1/8" 1076mm x 899mm x 2010mm	208/240V 1Ø or 3Ø	8,700/ 10,800	42/ 45	19 32 26 21 35 27	NEMA 15-60P NEMA 15-60P	775
WV2HSGRW	42-3/8" x 35-3/8" x 79-1/8" 1076mm x 899mm x 2010mm	208V 3Ø 240V 3Ø	9,600/ 12,000	46 50	24 35 27 26 38 27	NEMA 15-60P NEMA 15-60P	770

Due to periodic changes in designs, methods, procedures, policies and regulations, the specifications contained in this sheet are subject to change without notice. While Wells exercises good faith efforts to provide information that is accurate, we are not responsible for errors or omissions in information provided or conclusions reached as a result of using the specifications. By using the information provided, the user assumes all risks in connection with such use.



Wells Manufacturing • 265 Hobson Street, Smithville, Tennessee 37166 U.S.A.
Phone : (314) 678-6314 • Fax (314) 781-5445
www.wells-mfg.com • Printed in the U.S.A.

Specifications are subject to change without notice and are not intended for installation purposes. See installation instructions prior to installing the unit.