

DESIGNED SMART. BUILT SOLID.®

INSTALLATION AND OPERATING INSTRUCTIONS

Countertop Round Warmer
Models: RW-1V (7 Qt. Capacity)
RW-2V (11 Qt. Capacity)



WARNING: California Residents Only. This product can expose you to chemicals including chromium which is known to the State of California to cause cancer and birth defects or other reproductive harm. For more information go to www.P65Warnings.ca.gov.



WARNING: Improper installation, operation, service or maintenance can cause property damage, injury or death. Read and understand these instructions thoroughly before positioning, installing, maintaining or servicing this equipment.



P/N 2M-79967117 REV C 08/21

APW Wyott Food Service Equipment Company
265 Hobson St. • Smithville, TN 37166

(800) 527-2100 Phone

apwwyott.com

TABLE OF CONTENTS

ITEM	PAGE	ITEM	PAGE
Owner's Information	2	Service Information	3
General Installation	2	Wiring Diagram	4
General Operating Instructions	2	Parts List & Exploded View	5
General Cleaning Instructions	2	Warranty	7
General Troubleshooting	2		
Specifications	3		
Installation, Elec	3		
Operations, Cleaning	3		

OWNER'S INFORMATION

General Installation

1. Always clean equipment thoroughly before first use. (See general cleaning instructions.)
2. Check rating label for our model designation & electrical rating.
3. Locate equipment on level counter and plug into a grounded outlet so that the plug is accessible. (See individual description for electrical loads) On units bearing the CE marking, the appliance must be connected by an earthing cable to all other unites in the complete installation and hence to an independent earth connection.

General Operating Instructions

1. All foodservice equipment should be operated by trained personnel.
2. Do not allow your customers to come in contact with any surface labeled "CAUTION HOT".
3. Where applicable, do not cook, warm or hold food directly in liner pans (well pans). Always use steam table pans/insets, etc.
4. Never hold food below 150°F (66°C).

General Cleaning Instructions

1. NEVER clean any electrical unit by immersing it in water. Unplug unit before surface cleaning. NEVER POUR COLD WATER INTO DRY HEATED UNITS.
2. Always clean equipment thoroughly before first use. Clean unit daily. Except where noted on charts: Use warm, soapy water. Mild cleansers & PLASTIC scouring pads may be used to remove baked-on food and water scale.
3. Unplug all units before cleaning or servicing. All service should be performed by an APW authorized service agency.
4. Do not use chlorides or chloride-based products in this unit. Always clean equipment before first use. Clean unit daily. Use warm, soapy water. Rinse thoroughly to remove all residue. Chlorides, chloride-based products and improper cleaning may cause corrosion and pitting. FAILURE TO COMPLY WITH THESE INSTRUCTIONS MAY VOID UNIT WARRANTY.

GENERAL TROUBLESHOOTING

Always ask & check:

1. Is the unit plugged in?
2. Check circuit breaker.
3. Is power switch on & pilot light glowing?
4. Check rating label. Are you operating unit on proper voltage?

If the supply cord is damaged, it should be replaced by an identical supply cord.

If the above checks out, and you still have problems, call an APW authorized service agency.

SPECIFICATIONS

Installation:

Follow General Instructions on previous page.

RW-1V (7qt.)120 Volts, 500 Watts, 4.2 Amps

RW-2V (11qt).....120 Volts, 700 Watts, 5.8 Amps

RW-2V (11qt).....220 Volts, 700 Watts, 3.2 Amps (For Export Only)

Operation:

1. Follow General Operating Instructions on previous page.
2. Add hot water-120°-140° (50°-60° C) to well pan. RW-1V uses 3 cups (0.7 litre); RW-2V uses 5 cups (1.2 litre).
3. Turn thermostat to “High” position and preheat for approximately 10 minutes.
4. Place covered inset with refrigerated or preheated product into well. Cook on “High”; if using refrigerated product, stir frequently.
5. Keep warm, re-adjust control to “Low” - “Medium” setting depending upon the amount and thickness of product in inset.
6. Keep covered to maintain ideal serving temperature.

Cleaning:

Daily Cleaning

1. Refrigerate remaining product.
2. Follow General Cleaning Instructions on previous page.

SERVICE INFORMATION

IF A SHORTAGE OR A PROBLEM, CALL – in the USA: (800) 527-2100

PLEASE FOLLOW THESE INSTRUCTIONS:

A. ON CALLS YOU WILL NEED TO GIVE THE FOLLOWING INFORMATION.



1. Name and title of person calling.
2. Phone number of person calling.
3. Business name.
4. Street address.
5. City, State, Zip.
6. Model Number (from serial plate).
7. Serial Number (from serial plate).
8. Date purchased (if serial number indicates date of manufacture is over 13 months old you will be asked to supply proof of purchase).
9. Purchased from.

B. FOR SHORTAGE – SUPPLY THE ABOVE INFORMATION AND FULLY EXPLAIN WHAT IS MISSING. It will be sent immediately – prepaid via UPS or equivalent. (Next Day Air or Priority shipments available at customer’s expense).

C. FOR EQUIPMENT PROBLEM – IF WITHIN ONE YEAR FROM DATE OF PURCHASE, THIS UNIT FAILS TO FUNCTION, YOU ARE ENTITLED TO – YOUR CHOICE OF 1, 2, OR 3.

1. **APW Wyott will replace the unit.**

When calling the factory, besides the above information you will need Electrical Characteristics, voltage and phase; describe the problems the best you can. The factory will require a *Visa or Master Card number and expiration date of same to assure return and/or validity of condition. Upon validation of credit card information, factory will strive to ship a replacement unit the same day if call is received before 3:00 p.m. Central Time or the next day if later. The replacement unit will be shipped prepaid regular UPS or equivalent. If requested Next Day Air or Priority, shipment will be made at customer's expense. Upon receipt it is the customer's responsibility to unpack the new unit taking care to preserve the packaging. Repack the unit being replaced in the same container using caution to pack properly and return this unit to the factory following the instructions supplied. Factory will supply return label and UPS call tag, both must be used. If original unit is returned within 30 days and is as represented the credit card validation will be cancelled.

	<p>*IMPORTANT - If factory does not receive the unit to be returned within 30 days, the unit will be billed to the credit card number supplied. If the returned unit is not as represented - i.e. out of warranty, customer abuse, then it will be billed to the credit card number supplied. In these cases, the person calling in the problem will be contacted and if applicable the returned unit if charged for will be returned to the original owner if requested.</p>	
-----------------------------------------------------------------------------------	--------------------------------------------------------------------------------------------------------------------------------------------------------------------------------------------------------------------------------------------------------------------------------------------------------------------------------------------------------------------------------------------------------------------------------------------------------------------------------------	-------------------------------------------------------------------------------------

- 2. You may take this unit to the APW Wyott Authorized Service Distributor. List of same is included with each product. If the problem is covered under warranty the unit will be repaired at no cost to you. If the Authorized Agency cannot repair same within a reasonable time while you wait, it will be returned to you prepaid, via UPS.
- 3. You can request the Authorized Service Distributor to service the equipment on site. If problem is covered under the warranty the parts and labor will be billed to the factory, the mileage and travel time will be responsibility of the owner.

THIS REPLACEMENT WARRANTY IS ONLY AVAILABLE ON SELECTED PRODUCTS SHIPPED WITHIN THE CONTINENTAL USA, ALASKA, HAWAII AND CANADA. AS WITH MOST WARRANTIES - WARRANTY IS ONLY VALID TO THE ORIGINAL END-USER/OWNER.

INSTRUCTIONS AND PROCEDURES MUST BE FOLLOWED OR THE WARRANTY IS VOID.

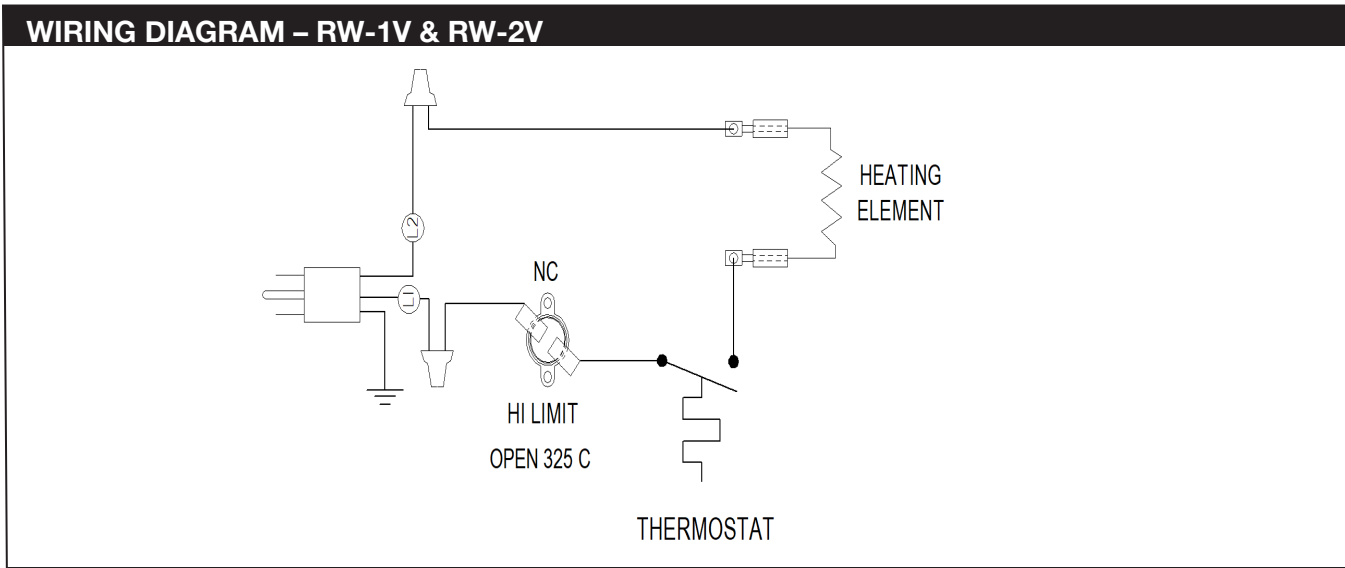

Model	Capacity	Voltage	P/N	Model	Capacity	Voltage	P/N	Model	Capacity	Voltage	P/N
RW-1V	7 Quart	120V	54810	RW-2V	11Quart	120V	54811	RW-2V Export	11Quart	220V	54809

EXPLODED VIEW – RW-1V & RW-2V

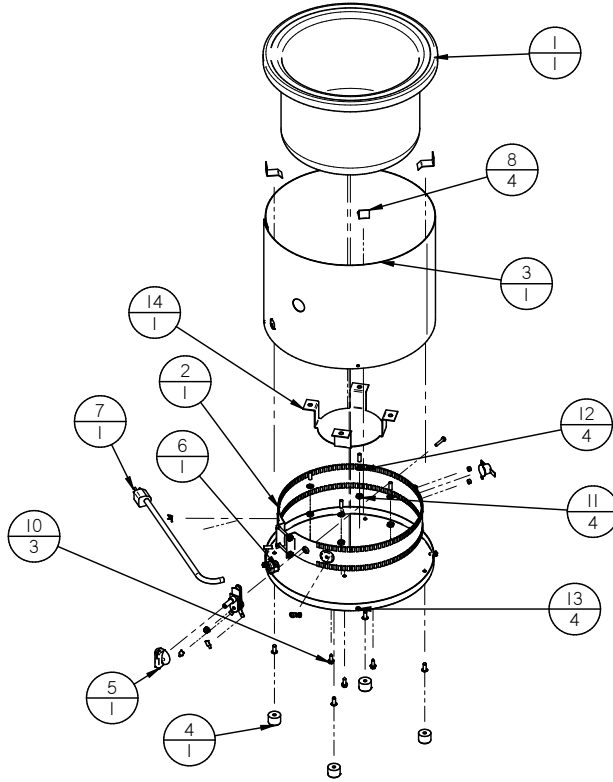

PARTS LIST – RW-1V & RW-2V

Item	P/N	Description
1	54840	WELL PAN 7QT 7QT RW-1V
2	54833	ELEMENT; ASSY 7qt VALUE 120V
3	54835-SPC	WRAPPER W/ASSY 7dt VALUE, WELDMENT
4	85873	COVER, BOTTOM ASSY 7QT
5	87146	KNOB; TSTAT BIMETAL W/CLIP
6	8967400	STRAIN RELIEF; 16/3 & 18/3 NYLON BLACK
7	55947	CORDSET 16GA; SJTO; NEMA 5-15P
8	85882	CLIP, WELD
9	1000900	SLEEVE, FIGBLS, #3 WIRE X .020WL
10	89073	SCREW 8X1/2 HEDH DSELF DRILL TYPE AB
11	89061	NUT; HEX 10-24
12	89059	WASHER, #10 EXTERNAL LOCK
13	89100	SCREW; 6-20 X 3/8 TEK 18-8
14	21808202	BRACKET; BOTTOM RW-1V & RW-2V

PARTS NOT SHOWN IN DRAWING

15	58182	LOGO; STRIPE; RW
16	75992	INSULATION; 6-1/2x30.5x1/2
17	57213	BOOKLET; COUNTER TOP INST/OPER
18	89701	LABEL; CAUTIONHOT/DONOTIMMERSE
19	89571	CARTON RW-1V W/GRAPHIES
20	70109985	INSERT; CONTAINER RW-1V
21	70109984	FILLER; SUPPORT RW-1V & RW-2V
22	58155	LABEL; FACTORY DIRECT SERVICE
23	67168	LETTER; IF A SHORTAGE TWO SIDED
24	58501	AUTHORIZED PARTS/SERVICE DISTRIBUTORS
25	58166	LABEL; RW & RCW THERMOSTAT
26	79967117	MANUAL; RW-1V; RW-2V
27	56980	INSULATION; 8-5/8X8X1/2
28	89479	WIRE; CONNECTOR
29	88961	NUT; HEX 10-24 GREEN/GROUND

Note: When ordering, ALWAYS specify Part #, Model #, Serial #, Voltage & Phase.

LIMITED EQUIPMENT WARRANTY

APW warrants to the original purchaser of new APW's products to be free from defects in material or workmanship, under normal and proper use and maintenance service as specified by APW and upon proper installation and start-up in accordance with the instructions supplied with each APW unit. APW's obligation under this warranty is limited to a period of one [1] year from the date of original installation, or eighteen [18] months from original invoice date, whichever occurs first. Defects that occur as a result of normal use, within the time period and limitations defined in this warranty, will at APW's discretion have the parts replaced or repaired by APW or a APW's-authorized service agency.

THIS WARRANTY IS SUBJECT TO ALL LISTED CONDITIONS

Repairs performed under this warranty are to be performed by an APW authorized service agency. APW will not be responsible for charges incurred or service performed by non-authorized repair agencies. In all cases, the nearest APW-authorized service agency must be used. APW will be responsible for normal labor charges incurred in the repair or replacement of a warranted product within 50 miles (80.5 km) of an authorized service agency. Time and expense charges for anything beyond that distance will be the responsibility of the owner. All labor will need to be performed during regular service hours. Any overtime premium will be charged to the owner. For all shipments outside the U.S.A. and Canada, please see the International Warranty for specific details. It is the responsibility of the owner to inspect and report any shipping damage claims, hidden or otherwise, promptly following delivery. No mileage or travel charges will be honored on any equipment that is deemed portable. In general, equipment with a cord and plug weighing less than 50 lb. (22.7 kg) is considered portable and should be taken or shipped to the closest authorized service agency, transportation prepaid.

CONTACT

Should you require any assistance regarding the operation or maintenance of any APW Manufacturing; phone or email our service department. In all correspondence provide the model number and serial number of the unit needing service; include the voltage or gas type.

Normal Business Hours: 8:00 a.m. to 4:30 p.m. Central

Telephone: 800-264-7827 Tech Service Option 2

Email: TechService@partstown.com

www.apwwyott.com

WARRANTY EXCLUSIONS

THE FOLLOWING WILL NOT BE COVERED UNDER WARRANTY.

APW's sole obligation under this warranty is limited to either repair or replacement parts, subject to the additional limitations detailed below. This warranty neither assumes nor authorizes any person to assume obligations other than those expressly covered by this warranty.

- Any product which has not been used, maintained, or installed in accordance with the directions published in the appropriate installation sheet and/or owner's manual, including incorrect gas or electrical connection. APW is not liable for any unit which has been mishandled, abused, misapplied, subjected to harsh chemicals, modified by unauthorized personnel, damaged by flood, fire, or other acts of nature [or God], or which have an altered or missing serial number.
- Installation, labor, and job checkouts, calibration of heat controls, air and gas burner/bypass/pilot adjustments, gas or electrical system checks, voltage and phase conversions, cleaning of equipment, or seasoning of griddle surface.
- Replacement of fuses or resetting of circuit breakers, safety controls, or reset buttons.
- Replacement of broken or damaged glass components, quartz heating elements, and light bulbs.
- Labor charges for all removable and consumable parts in gas charbroilers and hotplates, including but not limited to burners, grates, and radiants.
- Any labor charges incurred by delays, waiting time, or operating restrictions that hinder a service technician's ability to perform service.
- Replacement of parts that fail or are damaged due to normal wear or labor for replacement of parts that can be replaced during a daily cleaning routine, such as but not limited to silicone belts, PTFE non-stick sheets, control labels, knobs, bulbs, fuses, quartz heating elements, baskets, racks, and grease drawers.
- Any economic loss of business or profits.
- Non-OEM parts. Use of non-OEM parts without APW's approval will void the warranty.
- Units exceeding one [1] year from original installation date, or more than eighteen [18] months from original invoice date, whichever comes first.

ADDITIONAL WARRANTIES

- Specific/chain-specific equipment may have additional and/or extended warranties.

The foregoing warranty is in lieu of any and all other warranties expressed or implied and constitutes the entire warranty.