



evo®

Operator's Manual

Indoor Use Only

Elevation™ 40E High Temp Griddle
High Performance Cooking Equipment



E470119



LISTED
E514595

Rev- 01/2022



SAFETY WARNINGS	3
LIMITED WARRANTY	4-5
INTRODUCTION	
What is Live-Action Display Cooking	6
A High Volume Griddle with Smart Heat™ Technology	6
About Evo America, LLC	6
EQUIPMENT FEATURES	
Know Your Elevation™ 40E High Temp Griddle	7
CONTROL PANEL	
Startup / Home Screen	8
Operation / Cooktop Status Screen	9
Administration Settings - Set Temperature Screen	10
MAINTENANCE	
Cleaning - The Cooking Surface	11
Cleaning - Removing and Washing The Spillover Tray	12
Cleaning - Drip Pan	13
Cleaning - Stainless Steel Top, Side and Back Panels	14
TROUBLESHOOTING ISSUES	
Display Screen Will Not Respond	15
The Display Appears Functional But There's No Heat	15
The Fan Continues To Operate After The Unit Is Off	15
APPENDIX 1-3	
#1 REQUIRED GRIDDLE CLEANING AND MAINTENANCE SCHEDULE	16
#2 CLEANING THE COOKING SURFACE	17
#3 SPECIFICATIONS	18

**Warranty Repair Service Provided By
Evo America, LLC**

**Please call 866-626-1802
Monday - Friday 8am-6pm PST**

FOR YOUR SAFETY - Storing Flammable Materials

DO NOT STORE OR USE GASOLINE OR OTHER FLAMMABLE VAPORS OR LIQUIDS IN THE VICINITY OF THIS OR ANY OTHER APPLIANCE.

**WARNING - Do Not Misuse Equipment**

IMPROPER INSTALLATION, ADJUSTMENT, ALTERATION, SERVICE OR MAINTENANCE CAN CAUSE PROPERTY DAMAGE, INJURY, OR DEATH. READ THE INSTALLATION, OPERATING AND MAINTENANCE INSTRUCTIONS THOROUGHLY BEFORE POSITIONING, INSTALLING, MAINTAINING OR SERVICING THIS EQUIPMENT.

PLEASE READ ALL SECTIONS OF THIS MANUAL AND RETAIN FOR FUTURE REFERENCE.

THE UNIT WHEN INSTALLED, MUST BE ELECTRICALLY GROUNDED AND COMPLY WITH LOCAL CODES, OR IN THE ABSENCE OF LOCAL CODES, WITH THE NATIONAL ELECTRICAL CODE.

Users are cautioned that maintenance and repairs must be performed by an Evo America, LLC Authorized Service Agent using genuine Evo America, LLC Replacement parts. Evo America, LLC will have no obligation with respect to any product that has been improperly installed, adjusted, operated or maintained in accordance with national and local codes or installation instructions provided with the product, or any product that has its serial number defaced, obliterated or removed, or which has been modified or repaired using unauthorized parts or by unauthorized service agents. The information contained herein, (including design and parts specifications), may be superseded and is subject to change without notice.

- This unit must be operated by a qualified person.
- **DO NOT** operate without reading this manual.
- **DO NOT** attempt to repair or replace any part of this appliance unless all main power supplies have been disconnected.
- **DO NOT** clean this appliance unless the power supply is disconnected.
- **USE EXTREME CAUTION** in setting up, operating and cleaning this appliance to avoid coming in contact with hot surfaces (including parts). Wear suitable protective clothing or use proper utensils to prevent the risk of burns.

IMMEDIATELY INSPECT FOR SHIPPING DAMAGE

All containers must be examined for damage before and during unloading. The freight carrier has assumed responsibility for its safe transit and delivery. If equipment is received damaged, either apparent or concealed, a claim must be made with the delivering freight carrier.



Commercial Limited Warranty for the Elevation™ 40E Griddle

Evo Inc. warrants to the original commercial food service purchaser that the Evo Elevation™ will be free from defects in material and workmanship for a period of one (1) year from the original installation date, or 90 days after shipment, whichever is earlier. Evo's obligation under this warranty shall be limited to replacing or repairing, at its option, any part found to be defective within the specified warranty period. Any labor expense or part failure incurred after the warranty period will be the responsibility of the end user.

This warranty is non-transferable and applies only to the original purchaser/owner to whom the Evo Elevation™ was delivered. Any such transfer shall void the warranty.

Cleaning and maintenance instructions are included in the Elevation™ Operators Manual and Evo provided training material.

Service calls and/or part replacement resulting from lack of maintenance may not be covered under this warranty.

THIS WARRANTY DOES NOT COVER

1. Damage, part failure or performance issues resulting from lack of maintenance as detailed in the Elevation™ Operators Manual and Evo provided training material. Cost of repair calls scheduled by Evo during the warranty period and found to be resulting from lack of recommended maintenance will be charged to the end user.
2. Any defect or cosmetic damage to cooktop or stainless-steel cabinetry due to or resulting from ordinary wear and tear, handling, abuse, misuse or during installation.
3. Any damage resulting from voltage conditions, blown fuses, open circuit breakers or any other damage due to the inadequacy or interruption of electrical service.
4. Any unit from which the serial number has been removed or altered, or modifications made by unauthorized service personnel.
5. Damages as a result of floods, winds, fires, lightning, accidents, corrosive environment, improper installation or installation not in accordance with local electrical codes.

Evo, or its suppliers, shall not be liable, directly or indirectly, under any circumstances for consequential or incidental damages, including, but not limited to: (i) any loss of business or profits; and (ii) labor, material or other charges, claims losses or damages incurred or suffered from, in connection with or in consequence of the working upon, alteration, or repair of any such defective products or parts by persons or firms other than contracted directly by Evo.



Commercial Limited Warranty for the Elevation™ 40E Griddle

WHEN WARRANTY REPAIR IS NEEDED

How To Contact Evo

1. Call Evo directly at 503-626-1802 or Toll-free at 866-626-1802
2. Email support@evoamerica.com

Information Needed

1. Provide the Elevation™ model and serial number
2. Provide as much detail as possible on the problem – what happened, when did the problem start
3. Provide any relevant pictures of damage or condition of unit
4. Provide phone numbers and email for site contact
5. Provide details on any special access or service company requirements that could prevent completion of a service call

Evo will contact the site to obtain details and ask diagnostic questions, and Evo will schedule an authorized warranty service provider. If determined necessary, Evo will send the required parts directly to the customer location to hold for a technician.

What is Live-Action Display Cooking

Live-Action Display Cooking is performed by a chef in front of an audience where the chef creates theater and participation by engaging people with the sights, sounds and flavors of freshly prepared food. Every culture cooks foods in an open kitchen or outdoors where food preparation is equal parts flavor and entertainment, and the cooking equipment is as varied as our culture such as American barbecue, French rotisserie and Brazilian churrasco, to Chinese wok and Japanese teppan cooking.

A High Volume Griddle with Smart Heat™ Technology

Of the thousands of variations of display cooking equipment a chef can employ, one of the most versatile cooking platforms is the heated flat plancha or teppan griddle plate. Unfortunately when used indoors, this style of griddle plate inevitably produces grease laden air which is an undesirable byproduct that can be a health hazard to both the chef and the audience. The conventional way of dealing with this issue is to install ventilation devices such as a grease hood above the griddle. This hood is connected to an air/grease duct that leads to the outside, providing the air passage through which grease laden air can be removed by a suction motor (often installed at the end of the air duct).

About Evo America, LLC

Evo was founded by innovative food people with a passion for cooking and entertaining. As a cooking equipment manufacturer, it's our love of connecting people around food that guides everything we do. Since 2001, we have built a full line of exceptionally energy-efficient gas and electric, indoor and outdoor, commercial and residential, flattop cooking equipment, all designed to create a social cooking experience. Made in America, Evo equipment is the leading live-action display cooking equipment in the world and built to last a lifetime. Our commercial cooktops are used by food service professionals and top chefs as a versatile cooking platform, and as a conduit to communicate a fresh-prepared, farm-to-table message. Evo commercial equipment can be found at Whole Foods, Google, Apple, Microsoft, Marriott, Sheraton, Hyatt, Hilton, and hundreds of other A-list companies. Our residential cooking appliances compliment indoor and outdoor kitchens, and are used by thousands of consumers as a fun, healthy, and social way to cook for family and friends.

Know Your Elevation™ 40E Griddle

High efficiency electric griddle with dimensions measuring 28.5" x 40" (724mm x 1016mm)

Large drip rail surrounds 3 sides of griddle

Heavy gauge stainless-steel food fence



208V, 3-Phase, 60AMP dedicated electrical circuit (45Amp maximum draw)

Grease pan door with large, 7 qt. capacity grease collection pan

Intuitive touch-screen control for setting temperature presets.

Adjustable 4" equipment legs to easily clean under griddle

Startup / Home Screen



Power Button

Model Name

System Version

Evo America, LLC. Contact Detail

Operation / Cooktop Status Screen

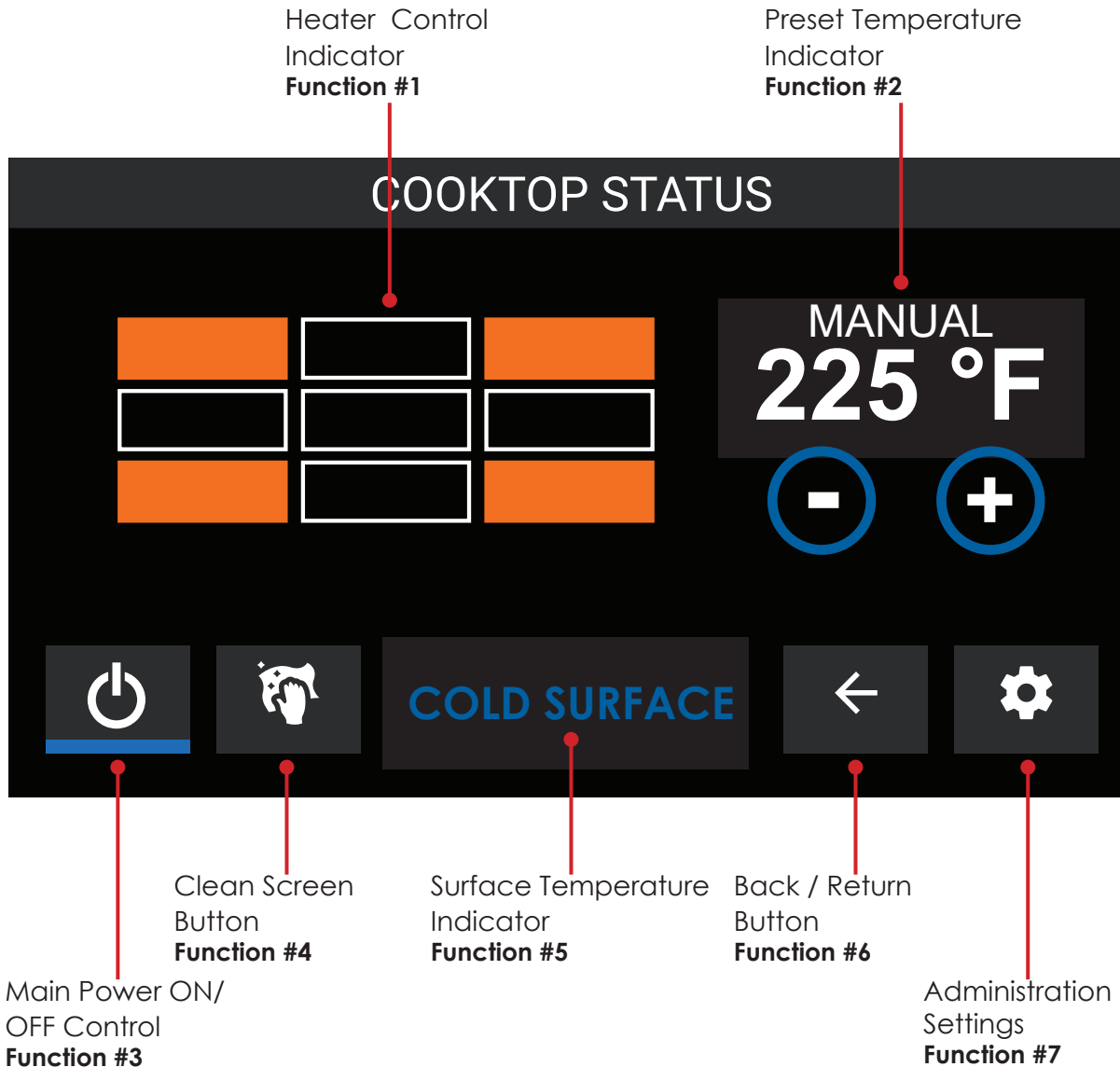

FUNCTION

- #1 Colored boxes indicate active individual heaters (If the outlined boxes are white, this indicates an inactive heater).
- #2 Shows currently selected Preset Temperature. There are two temperature presets and a manual option available. Raise and Lower buttons will only be visible when using manual mode.
- #3 Main Control button is used to place the griddle into standby mode. This will stop all heating functions.
- #4 Clean Screen button is pressed before cleaning the display screen.
- #5 Shows Cold Surface if griddle cooking surface is less than 125°F.
- #6 Used to return to the previous screen, when available.
- #7 Used to enter the SET TEMPERATURE screen to change or select the PRESET temperatures.

Administration Settings - Set Temperature

Select Preset 1, 2 or Manual.

Function #1

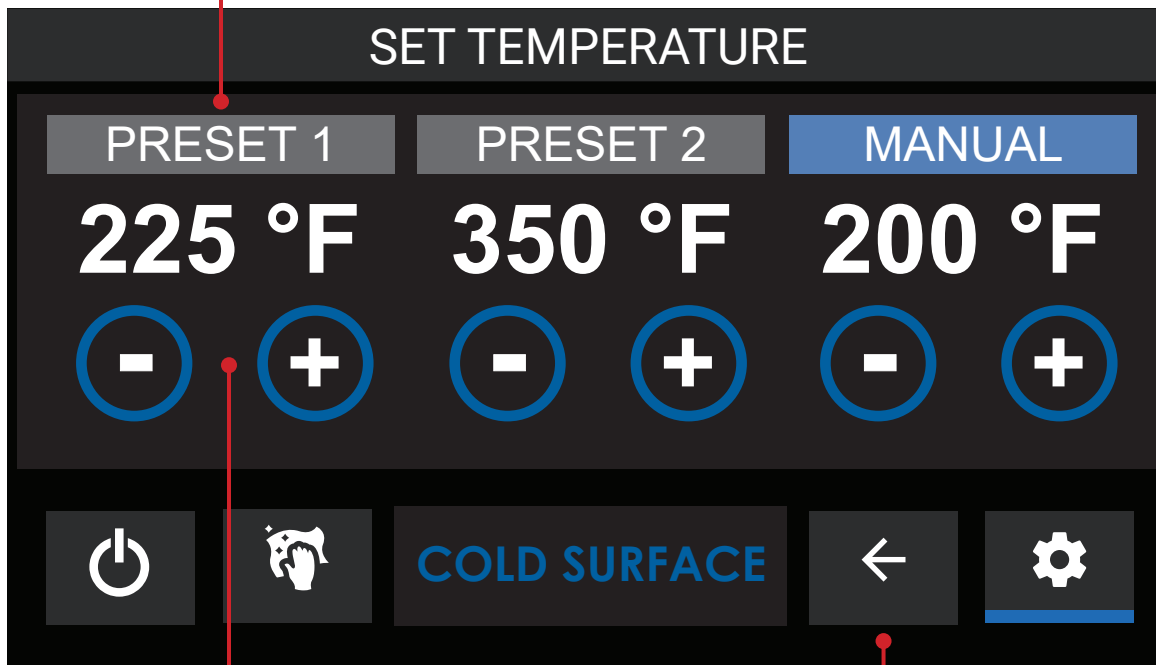

Use “+” or “-” to set temperature.

Function #2

Back / Return Button

Function #3

FUNCTION

- #1 Select a Preset and set the temperature. It is recommended to set temperature presets for 1, 2, and Manual based on menu plan.
- #2 To increase temperature select the “+” button.

To decrease temperature select the “-” button.
- #3 Press the back arrow icon ← to return to the previous screen.

Cleaning - The Cooking Surface

There are several methods for cleaning the cooking surface. The following guidelines are offered as a 'best practice' method for the Elevation™ 40E Griddle.

1. Using a scraper or spatula, scrape and remove loose debris by sweeping into the spillover slot.
2. While the cooking surface is still warm, scrub the surface with a grill pad with a small amount of oil in a circular motion, using a grill pad holder to maintain even pressure on the pad.
3. For heavy carbon buildup, it may be necessary to use a grill screen in combination with the grill pad.
4. Thoroughly wipe the surface with a terry cloth towel to remove any debris from the grill pad and grill screen.
5. Apply a thin layer of vegetable oil over the entire surface with a clean cloth to condition the steel surface and help prevent rusting.

SEE APPENDIX 2 FOR DETAILED GRIDDLE SURFACE CLEANING INSTRUCTIONS

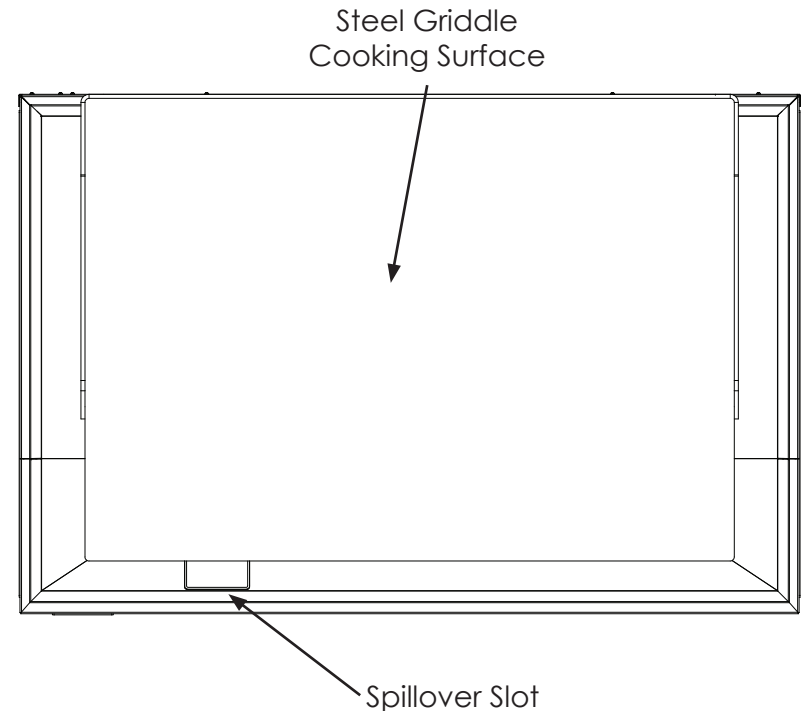

Cleaning handle,
Pad and screen.



Scraper



CAUTION: Do not pour water onto hot griddle surface because super heated steam can develop and cause severe skin burns.

Cleaning - Removing and Washing Spillover Pan and Drawer

Establish a daily cleaning cycle to keep the spillover pan and enclosure area clean and free of debris. Empty and clean the spillover pan often to avoid unnecessary overflow of the spillover pan.

1. To remove the spillover pan, open the waste door and remove the pan. Use caution and keep the pan level to prevent spills.
2. Return a clean pan to the drawer and close the waste door.
3. Remove the pan daily for cleaning inside the enclosure. To remove the pan, open the waste door by grasping the bottom slot and pull out while lowering the door. Thoroughly clean inside the enclosure and the spillover slot.

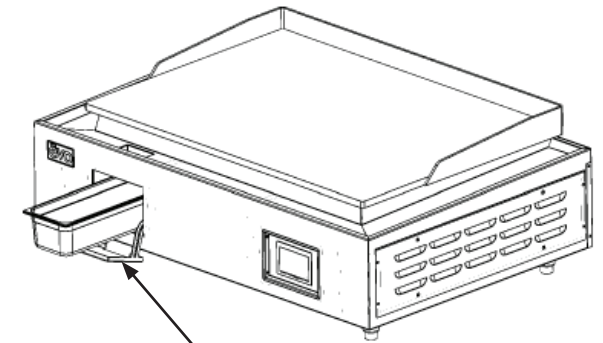

Open waste door and remove spillover pan.

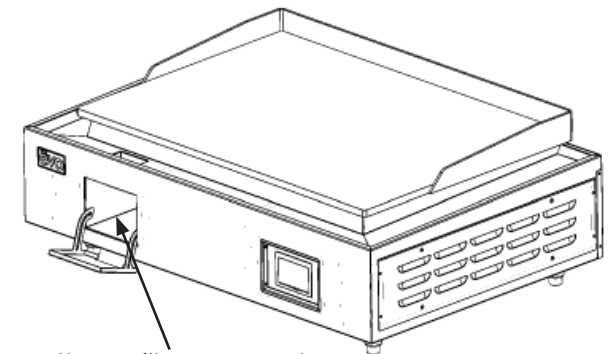

Remove the spillover pan to clean inside the enclosure and under the pan daily.



Thoroughly clean inside the enclosure and the spillover slot.

Cleaning - Drip Pan

Establish a regular cleaning schedule to ensure all food debris and spills are cleaned daily.

1. Using terry cloth or paper towels, clean the drip pan area around the cooking surface to remove oil and food debris. Where necessary, use warm soapy water to soften and remove debris.

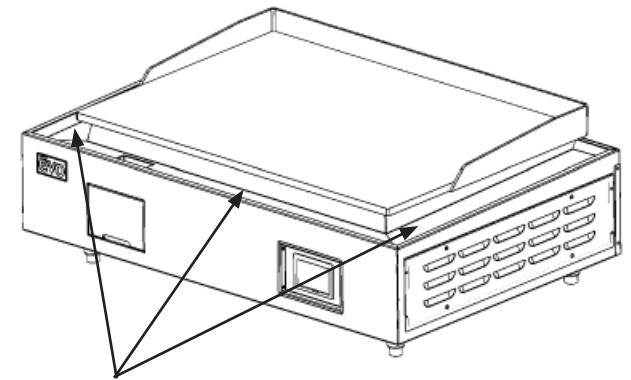

Clean the stainless steel drip pan area under the cooking surface.



Always use a non-abrasive cleaner when cleaning stainless steel areas to avoid scratching, dulling or damaging the surfaces.

Cleaning - Stainless Steel Top, Sides and Back Panels

Regularly clean the exterior stainless steel panels and keep the LED display panel area clean and free of food splatters. Also, check regularly under the unit to ensure there is no excess lint or debris blocking airflow from the discharge fans. Regular cleaning will preserve the integrity of the display control surface and overall appearance of the unit.

1. Wipe exposed, cleanable stainless steel surfaces when cool with a mild detergent and warm water. Stubborn residue spots should be soaked with warm soapy water and rubbed clean with a terry cloth or paper towel. Dry thoroughly with a clean cloth.
2. Always rub stainless steel in the direction of the metal grain to prevent scratching. Use a stainless steel cleaner if you want a high shine. Never use abrasive scour pads or steel wool on stainless steel.
3. The control panel surface is made from a plastic material and requires delicate cleaning. Use warm soapy water and a soft cloth. **Do not power wash, do not use abrasive scour pads or solvent cleaners since these will damage the control panel.**
4. Never spray the louvered areas or control panel with steam or water, this will allow moisture into the control cavity which could damage electrical components.

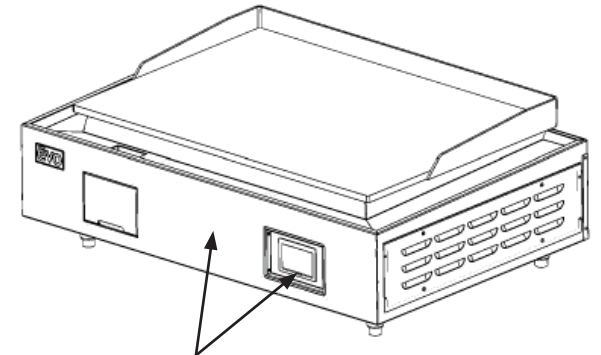

Clean the stainless steel and display area with a terry cloth or paper towels and warm soapy water. Never power wash or use abrasive cleaning pads.

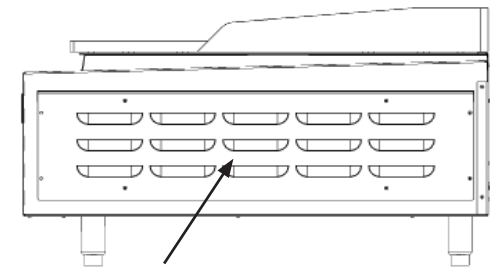

Clean the inlet air louvers on each side and make sure there is no excess build-up of lint or dirt. Use a brush as necessary to remove debris from the louver area.

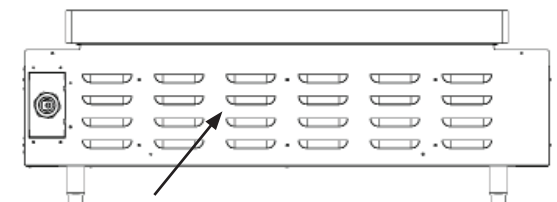

Clean the inlet air louvers on back and make sure there is no excess build-up of lint or dirt. Use a brush as necessary to remove debris from the louver area.



Inspect all exterior surfaces as often as possible to ensure they are kept clean and there is no debris blocking airflow across the side louvers or bottom fan screens.

TROUBLESHOOTING ISSUES

This section describes how to solve common problems you may encounter when using your Elevation™ 40E Griddle. Many problems have simple solutions.

#1 Display Screen Will Not Respond

1. Ensure the unit is plugged into a correct voltage and amperage electrical circuit. (See Appendix 3)
2. If a cord and plug is installed, have a certified electrician check the cord wiring has not become dislodged from inside the plug thereby preventing a secure electrical connection.
3. Check the electrical breaker panel to ensure the circuit breaker has not tripped. If it has been tripped, reset the breaker by switching to the "On" position.

#2 The Display Appears Functional But There's No Heat On The Cooking Surface

1. Ensure the Power button has been pressed and the screen has switched to the Cooktop Status screen. Ensure there are colored boxes cycling on the display screen.
2. Check the unit is connected to the correct voltage and amperage electrical circuit. (See Appendix 3)
3. Unplug the unit from power or cycle electrical breaker to reset the CPU control program.

#3 The Cooling Fans Continue To Operate After The Unit Is Turned Off

1. This is normal. The fans will continue to operate until the cooking surface temperature is below 125°F (52C).

REQUIRED Elevation™ 40E GRIDDLE SYSTEM CLEANING AND MAINTENANCE SCHEDULE

DAILY MAINTENANCE

1) Remove and clean the spillover pan.

2) Clean the drip pan area around the cooking surface.

3) Clean the cooking surface per the recommended instructions (APPENDIX 2).

WEEKLY MAINTENANCE

1) Clean the louvers on each side and ensure there are no food spills, lint or dirt blocking louver airflow.

2) Clean the discharge fan screens and make sure there is no food spills, lint or dirt blocking airflow from the discharge fans.

Please Contact Evo America, LLC for Evo Genuine Parts and Accessories.

**Phone: 866-626-1802
Monday - Friday from 8am to 5pm PST**

CLEANING THE COOKING SURFACE

It's important to keep your cooking surface clean to prevent food from sticking, to provide better heat conductivity, to prevent unwanted flavors and to provide a better overall appearance of your display cooking unit.

PROCEDURE

<p>1. Start by scraping large particles of debris with the provided scraper. Scrape the debris into the spillover tray located at the lower left of the cooking surface.</p>
<p>2. Place one gray polishing pad between the handle base and one grill screen, so the grill screen makes direct contact with the cooking surface.</p>
<p>3. Pour a small amount of vegetable oil on the cook surface and lightly scrub the surface in a circular motion.</p>
<p>4. Wipe the surface clean with a paper towel or cotton terry cloth towel.</p>
<p>5. Finish by wiping a small amount of vegetable oil over the entire surface to condition the steel surface and help prevent rusting.</p>

TOOLS NEEDED TO PROPERLY CLEAN THE COOKING SURFACE

Metal Scraper
Grill Screen
Grill Polishing Pad
Grill Pad Holder
Vegetable Oil
Paper Towels or Terry Cloth Towels

TIPS FOR SUCCESS

<p>1. The cooktop is easier to clean when slightly warm.</p>
<p>2. Clean the cooktop after each use.</p>
<p>3. A scraper works very well for removing heavy food particles.</p>
<p>4. Small amount of water can be used to loosen food particles when the cooktop is slightly warmed. Never put water on a hot cooking surface because super-heated steam may develop and cause severe skin burns.</p>



Specifications	9 Heating Elements (Only 5 heaters energized at any given time)
Cooking Surface Dimensions (Overall griddle size)	40" x 28.5" (1016mm x 724mm)
Heating Element Voltage (V)	208V
Phase	3
Frequency (Hz)	60 HZ
Current (A)	45 A (With a maximum of 5 heaters energized)
Maximum Current Requirement (A)	60 A Breaker
Power Cord	600V Type SOOW 4/4 4AWG, 6ft with NEMA 15-60 Plug



Evo America, LLC

20360 SW Avery Ct., Tualatin, OR 97062 USA
Ph 866.626.1802 Fax 503.213.5869 sales@evoamerica.com

Evo is protected under U.S. Patents 9,897,328, 9,869,474, 10,139,113, 9,903,595, 10,842,540, 7,825,353 and U.S. Patents Pending. Evo is a registered trademark of Evo America, LLC. ©2023 All rights reserved.