



**IMPORTANT FOR FUTURE REFERENCE**

Please complete this information and retain this manual for the life of the equipment:

Model #: \_\_\_\_\_

Serial #: \_\_\_\_\_

Date Purchased: \_\_\_\_\_

# Installation & Operation Manual

## FBG18 & FBG24 Fryers



## TO THE PURCHASER, OWNER AND STORE MANAGER

Please review these warnings prior to posting them in a prominent location for reference.

### TO THE PURCHASER

Post in a prominent location the instructions to be followed in the event that an operator smells gas. Obtain this information from your local gas supplier.

### FOR YOUR PROTECTION

DO NOT store or use gasoline or other flammable vapors and liquids in the vicinity of this or any other appliance. Do not spray aerosols in the vicinity of this appliance when it is in operation.

### WARNING

Improper installation, operation, alteration, adjustments, service or maintenance can cause property damage, injury or death. Read the installation, operating and maintenance instructions thoroughly before installing, operation, servicing this appliance.

### WARNING

Installation, maintenance and repairs should be performed by a Pitco Authorized Service and Parts (ASAP) company technician or other qualified personnel. Installation, maintenance or repairs by an unauthorized and unqualified personnel will void the warranty.

### WARNING

Installation and all connections must be made according to local codes in force. In the absence of local codes in North America, the installation must conform with the National Fuel Gas Code, ANSI Z223.1/NFPA 54 or the Natural Gas and Propane Installation Code CSA B149.1 as applicable. In Australia, the appliance must be installed in compliance with AS/NZS 5601.

### WARNING

DO NOT alter or remove structural material on the appliance to accommodate placement under a ventilation hood.

### WARNING

During the warranty period if a customer elects to use a non-original part or modifies an original part purchased from Pitco and/or its Authorized Service and Parts (ASAP) companies, this warranty will be void. In addition, Pitco and its affiliates will not be liable for any claims, damages or expenses incurred by the customer which arises directly or indirectly, in whole or in part, due to the installation of any modified part and/or received from an unauthorized service center.

### WARNING

This appliance, when installed, must be electrically grounded in accordance with local codes, or in the absence of local codes, with the National Electrical Code, ANSI/NFPA 70, or the Canadian Electrical Code, CSA C22.2, as applicable and the hose must comply with AS/NZS 1869 and be class B or D.

### WARNING

Adequate means must be provided to LIMIT the movement of this appliance without depending on the gas or electrical cord connection. Single appliances equipped with legs must be stabilized by installing anchor straps. All appliances equipped with casters must be stabilized by installing restraining chains.

### WARNING

An appliance equipped with casters and a flexible gas line must be connected to the gas supply with a quick disconnect device. In North America this quick disconnect must comply with ANSI Z24.41. In Australia, the quick disconnect must comply with AS 4627.

### WARNING

The power supply must be disconnected before servicing, maintaining or cleaning this appliance.

## **TO THE PURCHASER, OWNER AND STORE MANAGER**

Please review these warnings prior to posting them in a prominent location for reference.

### **WARNING**

If the appliance is equipped with a power cord and it is damaged, it must be replaced by an Pitco Authorized Service and Parts (ASAP) company technician, or a similarly qualified person in order to avoid a hazard.

### **WARNING**

The appliance is NOT jet stream approved. DO NOT clean the appliance with a water jet.

### **WARNING**

DO NOT attempt to move this appliance or transfer hot liquids from one container to another when the unit is at operating temperature or filled with hot liquids. Serious personal injury could result if skin comes in contact with the hot surfaces or liquids.

### **WARNING**

DO NOT use an open flame to check for gas leaks!

### **WARNING**

DO NOT sit or stand on this appliance. The appliance's front panel, tank, splash back, tank cover, workshelf, drain board is not a step. Serious injury could result from slipping, falling or contact with hot liquids.

### **WARNING**

NEVER use the appliance as a step for cleaning or accessing the ventilation hood. Serious injury could result from slips, trips or from contacting hot liquids.

### **WARNING**

The oil/shortening level should NOT fall below the minimum indicated level line at any time. The use of old shortening can be dangerous as it will have a reduced flash point and be more prone to surge boiling.

### **WARNING**

The contents of the crumb catch and/or filter pan of any filter system must be emptied into a fireproof container at the end of the frying operation each day. Some food particles can spontaneously combust into flames if left soaking in certain oil/shortening materials.

### **WARNING**

Completely shut the appliance down when oil/shortening is being drained from the appliance. This will prevent the appliance from heating up during the draining and filling process. Serious injury can occur.

### **WARNING**

This appliance is intended for indoor use only.

### **WARNING**

DO NOT operate appliance unless all panels and access covers are attached correctly.

### **WARNING**

It is recommended that this appliance be inspected by a qualified service technician for proper performance and operation on a yearly basis.

### **WARNING**

There is an open flame inside this appliance. The unit may get hot enough to set nearby materials on fire. Keep the area around the appliance free from combustibles.

### **WARNING**

DO NOT supply the appliance with a gas that is not indicated on the data plate. If you need to convert the appliance to another type of fuel, contact your dealer.

### **WARNING**

Never add oil to the appliance when it is at operating temperature. Splashing hot oil can cause severe injuries.

## **TO THE PURCHASER, OWNER AND STORE MANAGER**

**Please review these warnings prior to posting them in a prominent location for reference.**

### **WARNING**

If gas flow to appliance is interrupted, or pilots extinguish, wait 5 minutes before attempting to relight the pilot to allow any residual gas in appliance to dissipate.

### **WARNING**

Ensure that the appliance can get enough air to keep the flame burning correctly. If the flame is starved for air, it can give off a dangerous carbon monoxide gas. Carbon monoxide is a clear odorless gas that can cause suffocation.

### **WARNING**

Never add water to hot oil. Violent boiling can occur causing severe injury.

### **WARNING**

This appliance is intended for professional use only and should be operated by fully trained and qualified personnel.

### **WARNING**

To avoid splashing of hot liquid when installed, this fryer must be restrained either in the manner of installation, or with adequate ties to prevent tipping.

### **WARNING**

In North America, gas appliances equipped with casters must be installed with connectors that comply with the Standard for Connectors for Movable Gas Appliances, ANSI Z21.69.CSA 6.16 Latest Edition. This connection should include a quick disconnect device that complies with the Standard for Quick Disconnect Devices for Use With Gas Fuel ANSI Z221.41.CSA 6.9 Latest Edition.

### **WARNING**

In Australia, an appliance equipped with casters and a flexible gas line must be connected to the gas supply with a quick disconnect device that complies with AS 4627 and a restraining cable. The restraining cable must not exceed 80% of the length of the flexible gas line.

### **WARNING**

Australian Propane or ULPG units require installation of an external regulator IF the supply pressure exceeds 3.0 kPa. If the provided regulator is not with the unit contact the dealer. DO NOT install without an approved regulator if the supply pressure is greater than 3.0 kPa as this can cause hazardous conditions and potential gas leaks.

### **WARNING**

This appliance is not intended for use by a person (including children) with reduced physical, sensory or mental capabilities, or lack of experience and knowledge, unless they have been given supervision or instruction concerning use of the appliance by a person responsible for their safety. Children should be supervised to ensure that they do not play with the appliance.

### **WARNING**

Children should not be in the vicinity of this appliance when it is being operated, cleaned, maintained or serviced nor allowed to play on and/or with the appliance at any time.

<b>1. INSTALLATION</b>	<b>7</b>
1.1. CHECKING AND UNPACKING YOUR NEW APPLIANCE	7
1.2. INSTALLATION CLEARANCES	7
1.3. HEAT DEFLECTOR INSTALLATION (IF EQUIPPED)	7
1.4. LEVELING THE APPLIANCE – LEGS/CASTERS	8
1.5. GAS CONNECTION	9
1.6. QUICK DISCONNECT CONNECTION	9
1.7. FUEL SUPPLY LINE LEAK AND PRESSURE TESTING	9
1.8. INSTALLATION SETUP	10
1.9. GAS TABLES (NOT APPLICABLE TO ALL MODELS)	10
1.10. ELECTRICAL CONNECTIONS	11
1.11. VENTILATION AND FIRE SAFETY SYSTEMS	11
1.12. INSPECTION	12
1.13. INITIAL ADJUSTMENTS	12
1.13.1. FILLING THE APPLIANCE FOR ADJUSTMENT AND INITIAL CLEANING	13
1.13.2. LIGHTING INSTRUCTIONS ELECTRONIC IGNITION SYSTEMS	13
1.13.3. PILOT FLAME ADJUSTMENT ELECTRONIC IGNITION SYSTEMS	14
1.13.4. BURNER SYSTEM ADJUSTMENT	14
1.14. INITIAL CLEANING	15
<b>2. OPERATION</b>	<b>16</b>
2.1. FILLING THE COOK TANK	16
2.1.1. FILLING THE TANK WITH LIQUID SHORTENING	16
2.1.2. FILLING THE TANK WITH SOLID SHORTENING	16
<b>3. APPLIANCE START UP</b>	<b>17</b>
3.1. COOKING	18
3.2. COOKING TIPS	18
<b>4. APPLIANCE SHUTDOWN</b>	<b>18</b>
4.1. STANDBY MODE	18
4.2. COMPLETE SHUTDOWN	19
<b>5. PREVENTATIVE MAINTENANCE</b>	<b>19</b>
5.1. DAILY PREVENTATIVE MAINTENANCE	19
5.1.1. DAILY CLEANING	19
5.1.2. FILTERING WITH A FILTER DRAWER (IF EQUIPPED)	19
5.1.3. FLUSH HOSE OPERATION (IF EQUIPPED)	19
5.1.4. REPLACING THE FILTER MEDIA (IF EQUIPPED)	20
5.1.5. APPLIANCE INSPECTION	20
5.1.6. CLEANING THE COOK TANK	21
5.1.7. CLEANING THE CABINET	21
5.1.8. FILTER CLEANING (IF EQUIPPED)	21
5.2. WEEKLY PREVENTATIVE MAINTENANCE	21
5.3. MONTHLY PREVENTATIVE MAINTENANCE	22
5.3.1. BOIL OUT PROCEDURE	22
5.3.2. TEMPERATURE CHECK	22
5.4. ANNUAL/PERIODIC PREVENTATIVE MAINTENANCE AND INSPECTION	23
5.4.1. SAFETY EVALUATION	23
5.4.2. MECHANICAL INSPECTION	23
5.4.3. TEMPERATURE CONTROL SYSTEM	23
5.4.4. FILTER SYSTEM (IF EQUIPPED)	23
5.4.5. GAS COMBUSTION SYSTEM	23

PITCO FBG SERIES INSTALLATION & OPERATIONAL MANUAL

5.5. VENTILATION HOOD.....24

6. TROUBLESHOOTING ..... 24

6.1. POWER FAILURE .....24

6.2. HIGH TEMPERATURE LIMIT SWITCH .....24

6.3. DRAIN VALVE INTERLOCK (NOT ON ALL MODELS) .....24

6.4. TROUBLESHOOTING CHARTS .....25

6.4.1. APPLIANCE TROUBLESHOOTING CHART .....25

6.4.2. FILTER TROUBLESHOOTING CHART (IF EQUIPPED) .....25

6.5. OVERALL DIMENSIONS AND WEIGHTS.....26

**WARNING**

**DO NOT obstruct the flow of ventilation, or air openings around the appliance. Adequate clearance around the appliance is necessary for servicing and proper component ventilation. Ensure that you meet the minimum clearance requirements specified in this manual.**

**WARNING**

**DO NOT install this appliance next to a water cooker, or use it in any way in which water can come in contact with the hot oil. Splash over of water into hot oil may result in a steam eruption, potentially causing hot oil to be ejected from the fryer, and creating a burn hazard.**

**WARNING**

**DO NOT sit or stand on this appliance. The appliance’s front panel, tank, splash back, tank cover, work shelf, drain board is not a step. Serious injury could result from slipping, falling or contact with hot liquids.**

**WARNING**

**The appliance must be restrained from tipping to prevent spilling of hot liquid. The appliance shall be restrained from tipping when installed, such as by connection to other appliances, installation in an alcove, or by separate means such as a mechanical tie to structural features. In the case where a mechanical tie is used, the appliance shall not be operated without first checking that the mechanical tie is in place**

# 1. INSTALLATION

## 1.1. CHECKING AND UNPACKING YOUR NEW APPLIANCE

Your new Pitco appliance has been carefully packed into one crate. Every effort has been made to ensure that it is delivered to you in perfect condition. Pitco does not assume responsibility for damage or loss incurred in transit

1. Upon Delivery, inspect for visible shipping damage in the presence of the trucking operator. If something appears damaged, file a claim for damages regardless of extent. If something is damaged, DO NOT sign the bill of lading.
2. Unpack and inspect unit for damage. Contact the shipper within 15 days and file a concealed damage claim; the shipper is only responsible for concealed damage for 15 days after delivery.
3. Remove the unit from the shipping pallet:
4. Do not allow the full weight of the unit to rest on the legs or caster (if installed) when removing the appliance from the shipping pallet. The casters can be bent or damaged if too much weight or force is applied to them from improper handling.
5. Check the packing list enclosed with your appliance to ensure that you have received all the parts to the appliance. If you are missing any parts, contact the dealer from whom the appliance was purchased.
6. Using the front cover of this manual, record the following for warranty service or future reference:
  1. Your Pitco model number.
  2. Fryer serial numbers (Found on the inner door of each fryer).
  3. The date purchased from your dealer invoice.

Once you have completed the above, the appliance is ready to be installed.

Although it may be possible for you to install and set up your new appliance, it is **STRONGLY** recommended that you have this done by qualified professionals. A qualified professional will ensure that the installation is safe and meets local building and fire codes.

## 1.2. INSTALLATION CLEARANCES

The clearances shown below are for combustible and non-combustible installations and will allow for safe and proper operation of your appliance.

	<b>Combustible Construction</b> Inches (centimeters)	<b>Non-Combustible Construction</b> Inches (centimeters)
<b>Back</b>	6.0" (15.2cm)	0.0" (0.0cm)
<b>Sides</b>	6.0" (15.2cm)	0.0" (0.0cm)
<b>Floor</b>	9" (22.86 cm)	9" (22.86 cm)

In addition to the above clearances there must also be at least 30 inches (76.2cm) of aisle space in front of the unit.

## 1.3. HEAT DEFLECTOR INSTALLATION (IF EQUIPPED)

If the appliance requires a heat deflector, you will find a removable label at the rear top edge of the unit. This label has instructions for positioning and installation of the heat deflector. Refer to the label and the instructions below to install the deflector.

1. Remove the two self-drilling screws from the top, back area of the appliance.
2. Position the heat deflector so that the angled portion of the deflector is facing toward the front of appliance. Secure the heat deflector to the back of the unit using the two previously removed fasteners.
3. When properly installed the angled section of the heat deflector will extend over the flue opening to redirect the heat. It **SHOULD NOT** cover the flue opening. Never allow anything to block the flue opening; this will cause the appliance to overheat and inhibit proper combustion, which could produce dangerous gases.

**1.4. LEVELING THE APPLIANCE – LEGS/CASTERS**

When you receive your appliance, it may come completely assembled with legs or optional casters. This appliance must be installed with legs or casters; it cannot be curb mounted. Curb mounting will seriously inhibit this appliance’s ability to effect proper component ventilation. The legs/casters must be installed before connecting the appliance to the power supply. The legs provide the necessary height to meet sanitation requirements and assure adequate air supply to the combustion system. To level the appliance, use the following procedure.

**Required tools:** Large pair of water pump pliers, Medium flat blade screwdriver, level 12” (30.5 cm) long max.

- 1 Position appliance in final installed location.
- 2 Apply level across front, and then the left and right side of unit, determine lowest point, and distance to level.
- 3 Add the distance determined in step 2 to caster or leg on the lowest corner of appliance.

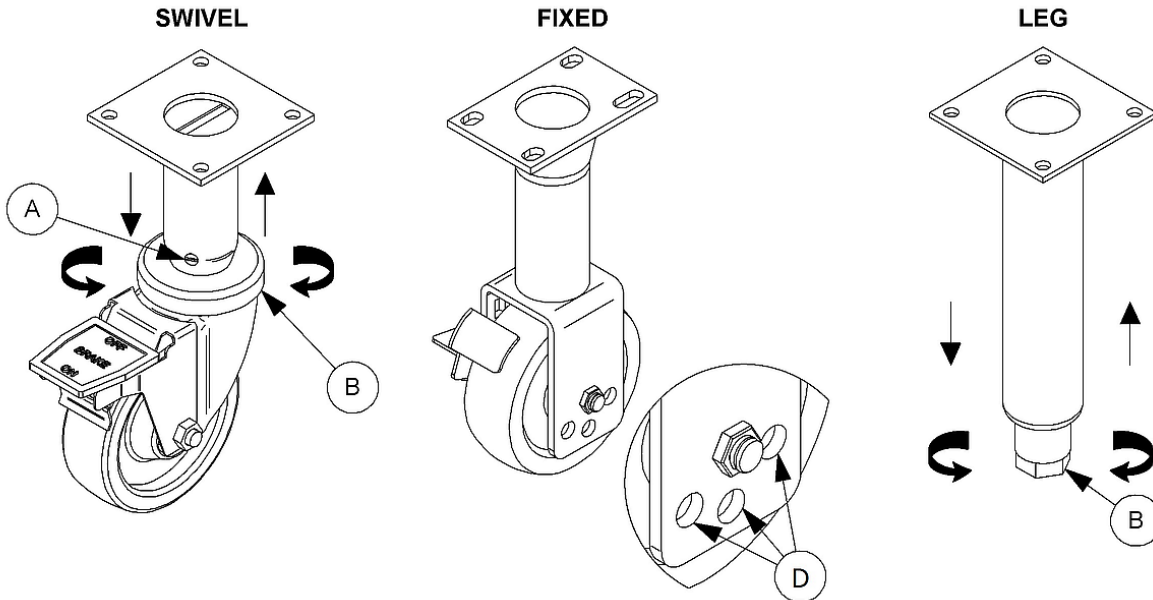

- a. Swivel casters- loosen 2 set screws (A)
  - b. Legs and swivel casters-. Adjust the height of the leg / caster by turning adjustment collar/ foot (B) with water pump pliers until desired change in height is achieved.  
Swivel casters only: Retighten set screws (A).
  - c. Fixed casters- Adjust height by moving wheel and axle to alternate holes (D) in wheel bracket higher or lower as needed. Refer to “FIXED” type caster in the illustration.
- 4 Adjust remaining casters or legs as needed to ensure the appliance is supported evenly at each caster/leg contact point.

<p><b>WARNING</b></p> <p><b>This appliance <u>must</u> be installed with the legs or casters provided by the manufacturer.</b></p>
<p><b>CAUTION</b></p> <p><b>To prevent equipment damage and/or personal injury, do not tilt the appliance onto any two of its casters or legs, or pull the appliance by the splash back.</b></p>
<p><b>WARNING</b></p> <p><b>DO NOT install legs or casters, or perform leveling procedure when appliance is in operation or full of hot liquids. Serious injury could result.</b></p>



## 1.5. GAS CONNECTION

Your gas appliance will give you peak performance when the gas supply line is of sufficient size to provide the correct gas pressure. The gas line must be installed to meet the local building codes or National Fuel Gas Code ANSI Z223.1 Latest Edition. In Canada, install the appliance in accordance with CAN/CGA-B149.1 or .2 and local codes. In Australia, install the appliance in accordance with AS/NZS 5601. Gas line sizing requirements can be determined by your local gas company or, in North America, by referring to the National Fuel Gas Code, Appendix C, Table C-4 (for natural gas) and Table C-16 (for propane). The gas line needs to be large enough to supply the necessary amount of fuel to all appliances without losing pressure to any appliance.

A properly sized and installed gas line will deliver a supply pressure between 7.0" W.C. (17.4mbars, 1.74kPa) and 10.0" W.C. (24.9mbars, 2.49kPa) natural gas or between 11.0" W.C. (27.4mbars, 2.74kPa) and 13.0" W.C. (32.4mbars, 3.25kPa) for propane to all appliances connected to the supply line, operating simultaneously at full demand.

- **THE PRESSURE AT THE GAS CONTROL VALVE SHALL NOT EXCEED ½ PSI (13.84 "WC, 34.5 mbar, 3.45 kPa).**

The gas supply connection to this appliance is located in the rear of the appliance approximately 10-1/2" (26.7 cm) from the floor of the appliance when legs are used.

Each appliance is equipped to operate on one certain fuel type. The type of fuel with which the appliance is intended to operate is stamped on the data plate, which is attached to the inside of the door.

**For Australian Propane/ULPG** units being installed on supply lines with pressures exceeding 3.0 kPa install the provided external regulator on the connection at the rear of each unit and connect gas lines to the regulators. Test pressure and adjust to 2.74 kPa.

### WARNING

**NEVER supply the appliance with a gas other than the one that is indicated on the data plate. Using the incorrect gas type will cause improper operation and could result in serious injury or death. If you need to convert the appliance to another type of fuel, contact the dealer you purchased it from.**

### NOTICE

**NEVER use an adapter to make a smaller gas supply line fit the appliance connection. This may not allow proper gas flow for optimum burner operation, resulting in poor performance and improper operation.**

## 1.6. QUICK DISCONNECT CONNECTION

In North America, gas appliances equipped with casters must be installed with connectors that comply with the Standard for Connectors for Movable Gas Appliances, ANSI Z21.69.CSA 6.16 Latest Edition. This connection should include a quick disconnect device that complies with the Standard for Quick Disconnect Devices for Use With Gas Fuel Appliances ANSI Z21.41.CSA 6.9 Latest Edition. In Australia, an appliance equipped with casters and a flexible gas line must be connected to the gas supply with a quick disconnect device that complies with AS 4627 and a restraining cable. The restraining cable must not exceed 80% of the length of the flexible gas line. The restraining device should be attached to the appliance at the back panel.

For Australia, the fryer must be installed in accordance with AS/NZS 5601, local authority and any other relevant statutory regulations. Flexible hose (if used) must comply with AS/NZS 1869 Class B or D, be of appropriate internal diameter, be kept as short as possible (not exceed 1.2 meters), must not be kinked and not be in contact with a hot surface. A chain must be fitted to restrict the fryer movement to no more than 80% of the hose length.

## 1.7. FUEL SUPPLY LINE LEAK AND PRESSURE TESTING

The fuel supply system must be tested before the appliance is used. If the fuel line is going to be tested at a pressure greater than ½ PSIG (3.45 kPa, 34.5 mbar), insure that that appliance is disconnected from the fuel line. If the fuel line is to be tested at a pressure equal to or less than ½ PSIG (3.45 kPa, 34.5 mbar), the appliance can be connected during the test, but the unit's gas control valve must be OFF. Test all gas line connections for leaks with a solution of soap and water when pressure applied.

1.8. INSTALLATION SETUP

The installation of this appliance *MUST* conform to local codes. In the absence of local codes in North America, the installation must conform with the National Fuel Gas Code, ANSI Z223.1/NFPA 54 or the Natural Gas and Propane Installation Code CSA B149.1 as applicable. In Australia, the appliance must be installed in compliance with AS/NZS 5601 (current revision).

**NOTICE**  
**If this appliance cannot be adjusted to perform correctly contact your local authorized service company or call the factory at the number on the back of this manual.**

1.9. GAS TABLES (NOT APPLICABLE TO ALL MODELS)

Refer to the following table for gas specifications for the country of use. If the country of use is NOT listed, refer to the information stamped on the data plate.

Applicable Countries	Model	Fuel Type	Gas	Appliance Category	Gross Input (kW)	Net Input (kW)	Supply Pressure (mbar)	Burner Pressure (mbar)	Burner Orifice	Pilot Orifice (code)	Governor	Nominal Gas Rate (m3/hr)
AT, BG, CH, CZ, DK, EE, FI, GB, GR, HR, HU, IE, IT, LT, LV, NO, PL, PT, RO, ES, SI, SK, SE, TR	FBG18	Nat	G20	I <sub>2H</sub>	29.3	26.4	20	10	#43	N22	YES	2.8
I <sub>2E</sub>												
G20/G25			I <sub>2E+</sub>	20/25	NO	2.8/3.2						
			I <sub>2ELL</sub>		YES							
G25-G25.3			I <sub>2L</sub> - I <sub>2EK</sub>	NOT AVAILABLE								
BE, BG, CH, CZ, DE, ES, FR, GB, GR, HR, HU, IE, IS, IT, LT, LU, LV, MK, MT, NL, PL, PT, RO, SI,	Pro	G31	I <sub>3P</sub>	29.3	27.0	37/50	25.4	1.45 mm	LP16	YES	1.1	
AT, BG, CH, CZ, DK, EE, FI, GB, GR, HR, HU, IE, IT, LT, LV, NO, PL, PT, RO, ES, SI, SK, SE, TR	FBG24	Nat	G20	I <sub>2H</sub>	35	31.5	20	10	#40	N22	YES	3.3
I <sub>2E</sub>												
G20/G25			I <sub>2E+</sub>	20/25	NO	3.3/3.9						
			I <sub>2ELL</sub>		YES							
G25-G25.3			I <sub>2L</sub> - I <sub>2EK</sub>	NOT AVAILABLE								
BE, BG, CH, CZ, DE, ES, FR, GB, GR, HR, HU, IE, IS, IT, LT, LU, LV, MK, MT, NL, PL, PT, RO, SI,	Pro	G31	I <sub>3P</sub>	35	32.2	37/50	25.4	0.0625"	LP16	YES	1.3	

**Belgium** – Natural gas units require a restrictor orifice on the supply line for proper operation.

Model	Fuel Type	Gross Input BTUS (kW)	Net Input BTUS (kW)	Supply Pressure (mbar)	Burner Pressure (mbar)	Burner Orifice	Pilot Orifice (code)
<b>NON-CE GAS TABLE</b>							
FBG18	Natural	100,000 (29.3)	26	7" W.C. (17.4)	4" W.C. (10)	#43	N22
	Propane			11" W.C. (27.4)	10 W.C. (25)	1.45 mm	LP16
FBG24	Natural	120,000 (35)	32	7" W.C. (17.4)	4" W.C. (10)	#40	N22
	Propane			11" W.C. (27.4)	10 W.C. (25)	.0625"	LP16

**1.10. ELECTRICAL CONNECTIONS**

It is advised that this power supply be plugged into a wall receptacle that is controlled by the ventilation control. This will prevent the appliance from being operated without the ventilator on. If your appliance requires an electrical connection, the power requirements are listed below.

<b>CAUTION</b>
<b>Connecting the appliance to the wrong power supply may damage the appliance and void the warranty.</b>
<b>WARNING</b>
<b>This appliance must be connected to a power supply having the same voltage and phase as specified on the data plate located on the inside of the appliance door.</b>

	North America	International
Input Voltage	120 VAC, 50/60 Hz	208, 220, 230 or 240 VAC 50/60 Hz
Current per unit	0.7 Amp	0.4 Amps
Filter Current	6.1 Amp	4.5 Amps

<b>WARNING</b>
<b>DO NOT attempt to connect the appliance to an electrical supply other than that indicated on the data plate. Electrical connection should be performed by qualified personnel.</b>

<b>WARNING</b>
<b>The electrical connection used by this appliance must comply with local codes. In the United States if there are no local codes that apply, refer to the National Electrical Code (NEC), ANSI/NFPA 70 for installation in the US. In Canada, refer to CSA Standard C22.2 and local codes. In all other cases, refer to local and national codes and regulations.</b>

<b>WARNING</b>
<b>If your appliance is equipped with an oil proof, electrical supply cord with a three-prong safety plug. DO NOT cut or remove the grounding (third) prong from this plug; it should be plugged into a properly grounded three-prong receptacle. This is to protect operators from electrical shock hazard in the event of an equipment malfunction.</b>

**1.11. VENTILATION AND FIRE SAFETY SYSTEMS**

Your new appliance must have proper ventilation to function safely and properly. Exhaust gas temperatures can reach as high as 1100 °F (593 °C). Therefore, it is very important to install a fire safety system. Your ventilation system should be designed to allow for easy cleaning. Frequent cleaning and proper maintenance of the ventilation system and the appliance will reduce the chances of fire. Ventilation and fire safety systems must comply to local and national codes for US and Canada. Refer to ANSI 83.11 for a list of reference documents that will provide guidance on ventilation and fire safety systems. For installations in U.S. and Canada, additional information can be obtained from CSA International, 8501 East Pleasant Valley Road, Cleveland, OH, 44131 or visit their website at [www.csa-international.org](http://www.csa-international.org). In Australia the ventilation system must comply with AS/NZS 5601.0.

It is essential that the appliance be operated only when adequate ventilation is provided. Your ventilation hood should be properly maintained. A qualified installation professional should ensure that the hood is operating properly in conjunction with the appliance. Inadequate ventilation may not properly evacuate appliance all emissions. Excessive or unbalanced ventilation may cause drafts, which could interfere with proper operation of the pilot and burners. Leave at least 18 inches (47cm) of open space between the flue of the appliance and the intake of the exhaust hood.

**WARNING**

Replacing or adding appliances under a pre-existing fire safety system may require modifications to the system. ALWAYS contact a professional who is qualified in installing, designing and maintaining your fire safety system to assure that any appliances located under the fire safety system are adequately protected.

**WARNING**

NEVER connect the ventilation blower or hood directly to the flue of this appliance. The resulting increased flow of air through the combustion system will cause improper operation, poor temperature recovery, poor ignition and could extinguish the pilot.

**WARNING**

Ensure that your ventilation system does not cause a down draft at the appliance's flue opening. A down draft will not allow the appliance to exhaust properly and will cause overheating, which may cause permanent damage. Damage caused by down drafts will not be covered by the warranty. NEVER allow anything to obstruct the flow of combustibles or ventilation exiting the appliance. NEVER place anything on top of the flue area, or block the flue in any way. Never place a grease condensing drip pan over the flue opening.

**1.12. INSPECTION**

Before you begin filling and adjusting the appliance, perform the following visual checks:

- ✓ After the appliance is in its permanent location, check the levelness. Any additional leveling that is necessary can be performed as previously described.
- ✓ Ensure that the probe and high temperature limit bulb is in place and secure. Check the high limit bulb and probe mounting bracket screws to ensure that they are tight.
- ✓ Review the installation portion of this manual and ensure that all steps have been followed and executed properly.

**1.13. INITIAL ADJUSTMENTS**

After your appliance has been properly installed as described in the installation section of this manual, it will need to be adjusted to ensure that it will perform as designed. A qualified person must perform these adjustments.

1. Probe
2. High Temperature Limit Bulb
3. Ensure that these parts are NOT loose.
4. Do NOT bend the tube to Item 2 or cause damage to Items 1 and 2.

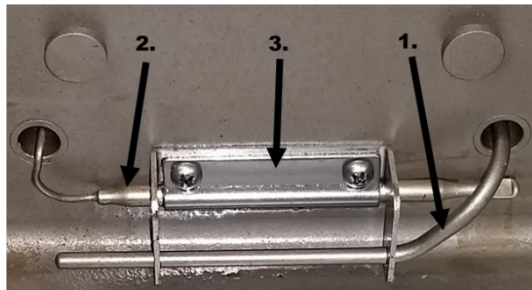

Ensure that the tank drain plug and probe guard is in place before filling and using the fryer

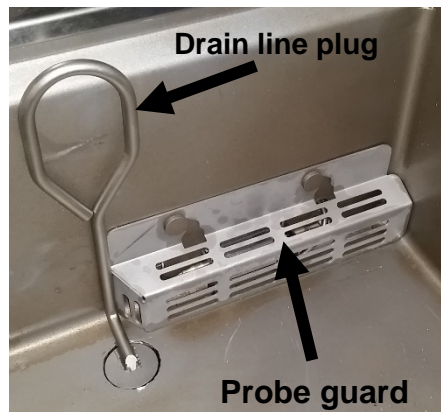

To perform these adjustments the following tools will be needed:

- Manometer
- Digital Thermometer (Temperature Probe)
- DC Microammeter
- DC Voltmeter

1.13.1. **FILLING THE APPLIANCE FOR ADJUSTMENT AND INITIAL CLEANING**

Refer to the following procedure to fill the cook tank prior to making adjustments.

1. Ensure that the drain valve is **closed**.
2. Fill the tank with WATER. Water is used for the installation adjustments because the temperature will never exceed 212°F (100°C), thereby allowing plenty of adjustment time. Never let the water level go below the MIN LEVEL mark stamped on the tank.

<p><b>WARNING</b> Oil/shortening must completely cover the tank bottom at all times while appliance is on.</p>
<p><b>CAUTION</b> This appliance is not designed for cooking with water. Fill with oil/shortening only.</p>
<p><b>WARNING</b> During operation there is an open flame inside this appliance. The unit may get hot enough to set nearby materials on fire. Keep the area around the appliance free from combustibles.</p>
<p><b>WARNING</b> If pilot extinguishes, wait 5 minutes before attempting to relight the pilot to allow any built-up gas to dissipate.</p>
<p><b>WARNING</b> Do not store flammable materials in or near this appliance. Do not spray aerosols in the vicinity of this appliance while it is in operation. Contact a qualified service person or the factory, using the information on the back of this manual, if the appliance produces unusual odor, yellow tipping flames or is not performing as per the original installation.</p>

1.13.2. **LIGHTING INSTRUCTIONS ELECTRONIC IGNITION SYSTEMS**

There is nothing to manually light on the electronic ignition system. Pilot ignition is performed and controlled by the electronic ignition system. Refer to the following instructions to light the appliance.

1. Open the gas supply valves to the appliance.
2. Turn the gas control valve knob to the ON position.
3. Turn the controller on.

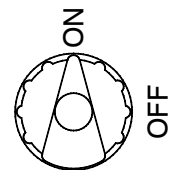

Gas Control Valve Knob

Solid State Thermostat:

Assure the Melt switch is in the correct position, Solid or Liquid oil/shortening.

Turn the I/O (ON/OFF) switch to the I (ON) position

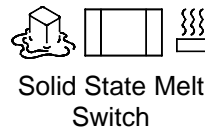

Solid State Melt Switch

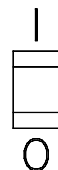

Solid State I/O ON/OFF Switch

Digital Control:

Press the \* button to turn the controller on.

**\*The specified button may appear slightly different than shown. Refer to the operator's manual for your appliance's specific control type to determine the exact appearance of each button and display.**

4. The burners will light and be controlled by the thermostat.

### 1.13.3. PILOT FLAME ADJUSTMENT ELECTRONIC IGNITION SYSTEMS

Perform this procedure with the pilot lit.

**Note: This procedure requires the use of a DC microammeter.**

1. Connect the DC microammeter between the flame sensor terminal and the flame sensor lead. Observe proper polarity: if the meter needle goes below 0, reverse the leads. The current reading must be 1.0  $\mu$ A or greater, (0.15  $\mu$ A or greater for CE units).
2. Adjust the current reading to the required level by adjusting the pilot flame. Remove the pilot adjustment cap screw to expose the pilot adjustment screw. Turning the pilot adjustment screw clockwise will decrease the size of the pilot flame and flame sense current. Turning the pilot adjustment screw counterclockwise will increase the pilot flame size and the flame sense current.
3. Rotate the screw in the direction needed to achieve a reading of 1.0  $\mu$ A or greater, (0.15  $\mu$ A or greater for CE units).

**Note: Allow 3 to 5 minutes between flame adjustments to allow the reading to stabilize.**

4. Once the pilot flame has been adjusted properly, replace the pilot adjustment cap screw and remove the microammeter.

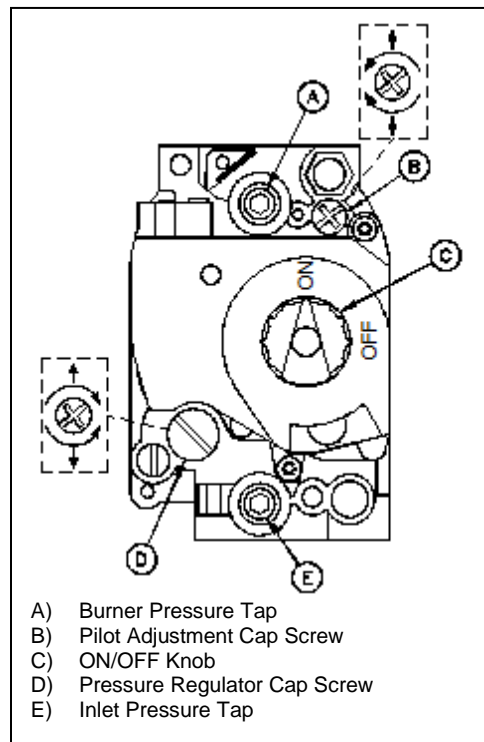

### 1.13.4. BURNER SYSTEM ADJUSTMENT

For the burners to operate the gas control valve must be open and the thermostat must be turned on. The main power switch must be on. The burners receive gas from the main gas supply through the thermostatically controlled gas control valve. When the oil temperature drops below the preset temperature the gas control valve opens.

The burners must be adjusted to deliver optimum flame. Refer to the following procedure to adjust the burners.

1. Ensure that the gas control valve is turned OFF, remove the burner pressure tap plug and connect an accurate pressure gauge (range of 0-16 "W.C. (39.85mbar, 3.98kPa) in 0.1" (.25mbar, .02kPa) increments) or manometer.
2. Turn on this and all appliances connected to the gas supply line and light their burners. The pressure reading of the installed pressure gauge should not drop from the required installation pressure. Any loss of pressure indicates inadequate supply line installation, which will cause poor performance of all appliances during peak usage.
3. The installed pressure gauge should be the same,  $\pm 0.1$ " W.C. (.25mbar, .02kPa), as that marked on the data plate on the inside door of the appliance. If the pressure is correct, go to step 6, if it is not, adjust the pressure as outlined in step 4.

To adjust the pressure, remove the pressure regulator cap screw and, with a flat head screwdriver, adjust the pressure regulator screw until the proper burner pressure is reached. Turning the screw clockwise will increase the burner pressure. Turning the screw counterclockwise will decrease the burner pressure.

**IF the pressure cannot be set to within these limits of the pressure stated on the data plate, DO NOT operate the appliance. Contact an Authorized Service Company.**

4. When the pressure is correct, replace the pressure regulator cap screw.

5. Turn off ALL appliances, turn OFF the gas control valve to your Pitco appliance and remove the pressure gauge. Apply pipe joint compound to the burner pressure tap plug and reinstall it.

**CAUTION**

**Be careful not to disturb the probe and high temperature limit during operation and cleaning of this appliance.**

**1.14. INITIAL CLEANING**

When your appliance is shipped, many of its parts are covered with a thin coat of oil for protection. Before the appliance is ready for cooking all transit material must be removed and the appliance must be cleaned. This will remove the oil coating and any foreign matter that may have accumulated during storage and shipment. Refer to the following procedure to clean the appliance.

**WARNING**

**Wear protective gloves and clothing when cleaning and draining the appliance and when disposing of water. The water is extremely hot and can cause severe injuries.**

**CAUTION**

**DO NOT leave the appliance unattended during cleaning. Never let the water level go below the "Min Level" mark.**

**Read the "operation" section of this manual prior to filling or operating the appliance.**

1. The following steps should be followed using a grease dissolving commercial cleaner.

**WARNING**

**Use a commercial grade cleaner formulated to effectively clean and sanitize food contact surfaces. Read the directions and precautionary statements before use. Particular attention must be paid to the concentration of cleaner and the length of time the cleaner remains on the food contact surfaces.**

2. Following the manufacturer's directions, clean the tank interior and all other food contact surfaces.
3. When cleaning is complete, rinse the inside of the tank thoroughly with cool water. Continue to rinse the tank until the cleaner has been completely and thoroughly rinsed from the tank.
4. Using a clean dry cloth, wipe out all of the water.
5. Repeat the previous steps to clean the bread and batter station or filter pan if equipped.
6. Mild steel tanks must be wiped down and coated thoroughly with oil to prevent the tank from rusting.

If the appliance can't be adjusted to operate properly contact a qualified service person or contact the factory using the contact information on the back of this manual.

## 2. OPERATION

An operator's manual for your appliance's specific control type should be included with this manual. Refer to that manual prior to operating this appliance.

FRYER MODEL	TANK OIL CAPACITY*		
	Lbs.	kg	liter
FBG18	42 - 65	19.1 - 29.5	21.0 - 32.4
FBG24	57 - 87	25.9 - 39.5	28.5 - 43.4

\* Per Tank, weight/volume based on Canola Oil

### 2.1. FILLING THE COOK TANK

Both liquid and solid shortening can be used in this appliance, but liquid is preferred. If solid shortening is used it is recommended that you melt the shortening before adding it to the appliance. You can melt solid shortening in the appliance, but you must be very careful not to scorch the shortening.

#### CAUTION

**This appliance is NOT designed for cooking with water. Fill with oil or shortening only.**

#### Level Marks

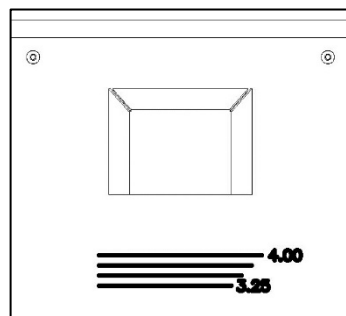

#### 2.1.1. FILLING THE TANK WITH LIQUID SHORTENING

To fill the tank with liquid shortening refer to the following procedure.

1. Ensure that the drain valve is completely closed and that there is no residual moisture in the tank.
2. Fill the tank with oil. You may fill the tank to the "4.00" mark the oil will expand slightly when it heats up, raising the level slightly.

#### WARNING

**NEVER melt blocks of solid shortening in the tank. This will cause a fire and could result in personal injury.**

#### 2.1.2. FILLING THE TANK WITH SOLID SHORTENING

To fill the tank with solid shortening refer to the following procedure.

1. Cut the solid shortening into cubes no larger than one inch. ALWAYS pack the shortening in the tank. Do NOT leave any large air gaps. Use care when packing the solid shortening into the tank. Do NOT bend or break the temperature or high limit sensor probes. If these are damaged the appliance will not function properly.
2. Once the appliance tank is firmly packed with shortening, the shortening must be melted. If your appliance has a Melt Cycle option, use this to melt the shortening automatically.
3. If you do not have a Melt Cycle and have a thermostat control melt the oil/shortening by cycling the burners ON for 4 seconds and OFF for 30 seconds repeatedly, using the thermostat knob.

#### WARNING

**Oil/shortening must completely cover the tank bottom at all times while appliance is on.**



### 3. APPLIANCE START UP

Refer to the following procedure to start the appliance prior to operation.

1. Ensure that the drain valve is closed.
2. Fill the cook tank with oil/shortening. (See section 2.1 “Filling the Cook Tank”) Never operate the appliance unless the cook tank is properly filled.

**WARNING**  
**NEVER operate the appliance with an empty fry tank. It will void the warranty.**

3. Light the appliance. (See “Lighting Instructions” section 1.13.2 depending on controls)

**Solid State Thermostat:**

- a. On the controller, switch the melt switch to the appropriate melt position. Turn the thermostat knob to the desired temperature. Switch the ON/OFF switch (I/O) to the ON ( I ) position. The appliance will execute its melt cycle and then bring the oil/shortening to the chosen setpoint.

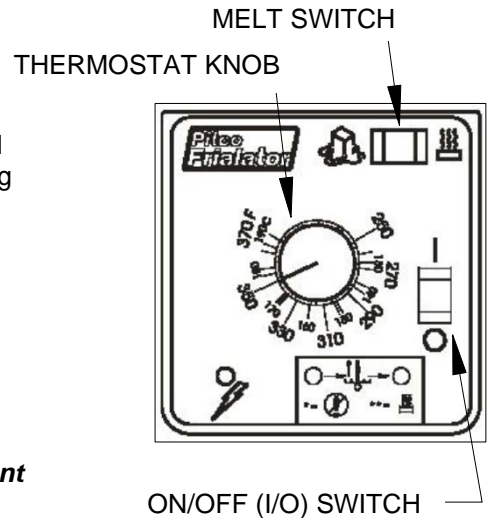

**Digital Control:**

Press the \* button to turn the controller on.

***\*The specified button may appear slightly different than shown. Refer to the operator’s manual for your appliance’s specific control type to determine the exact appearance of each button and display.***

4. The burners will light and be controlled by the thermostat.
5. The appliance is now on and heating the oil/shortening in the cook tank.

**CAUTION**  
**DO NOT attempt to operate this appliance during a power outage.**

If your appliance is supplied with AC power and it is interrupted or removed for any reason during operation, the appliance will shut down. Wait five minutes after the power is restored before attempting to restart the appliance. This will allow time for any gas that may have accumulated in the burners or combustion chamber to dissipate. To restart the appliance, follow the appliance start up procedure in this manual.

**OIL TEMPERATURE**

Keep the oil temperature in the fryer to a maximum of 190°C (374°F). Higher temperatures will cause rapid breakdown of the oil and give you no faster cooking. At 205°C (401°F) to 210°C (410°F) the life of the oil is only one third of its life at 190°C (374°F). In addition, increased decomposition causes the oil to smoke badly even if the temperature is lowered to 190°C (374°F) again. High temperatures give you no advantage, cost you money and increase the fire danger.

**TEMPERATURA DELL'OLIO**

Mantenere la temperatura dell'olio nella friggitrice fino a un massimo di 190°C. Temperature maggiori causano un rapido degrado dell'olio, senza tuttavia eseguire una cottura più rapida. Da 205°C a 210°C la durata dell'olio è inferiore di un terzo rispetto a quella a 190°C. Inoltre, l'accresciuta decomposizione comporta una forte emissione di fumo, anche se la temperatura viene riportata di nuovo a 190°C. Le alte temperature non prevedono vantaggi, sono antieconomiche e aumentano il rischio d'incendio.

**ΘΕΡΜΟΚΡΑΣΙΑ ΛΑΔΙΟΥ**

Διατηρείτε τη θερμοκρασία λαδιού στη φριτέζα μέχρι 190 βαθμούς Κελσίου. Υψηλότερες θερμοκρασίες θα αλλάξουν τη σύνθεση του λαδιού πολύ σύντομα και δεν ψήνετε γρηγορότερα. Η δυναμικότητα του λαδιού στους 205-210 βαθμούς Κελσίου είναι μόνο το ένα τρίτο της δυναμικότητάς του στους 190 βαθμούς Κελσίου. Επιπλέον η αυξημένη αποσύνθεση του λαδιού, σε θερμοκρασίες πάνω από 190 βαθμούς Κελσίου, κάνει το λάδι να καπνίζει άσχημα κι αν ακόμη κατεβάσετε τη θερμοκρασία κατόπιν πάλι στους 190 βαθμούς Κελσίου. Οι υψηλές θερμοκρασίες δε σας παρέχουν κανένα πλεονέκτημα, σας κοστίζει περισσότερα χρήματα και αυξάνουν τον κίνδυνο πυρκαγιάς.

**WARNING**

**Dry fired tanks are extremely hot, will shorten its service life and will void your warranty.**

**WARNING**

**Oil/shortening level should NOT be allowed to fall below the minimum indicated level line at any time. Dry firing of the fry tank will shorten tank service life and will void your warranty.**

**3.1. COOKING**

To ensure the quality of the food you cook in this appliance, follow the preparation instructions from the food manufacturer. When the appliance is not in use, the oil/shortening should be cooled and covered to prevent contamination.

**3.2. COOKING TIPS**

- ✓ Always follow the food manufacturer's directions.
- ✓ The lower the oil temperature, the longer the cooking time and the greater the fat absorption.
- ✓ Oil/shortening quality can affect product quality. Keep salt and water away from the oil/shortening to maintain its life. Oil/shortening filtration removes crumbs from the oil which will also extend its life.

**4. APPLIANCE SHUTDOWN**

There are two shutdown modes of appliance operation: STANDBY and COMPLETE. The standby mode removes the ability of the appliances burners to operate. Complete shutdown turns off the gas supply to the appliance. Refer to the following procedures to enter the appropriate shutdown mode.

**4.1. STANDBY MODE**

1. Turn the temperature controller or thermostat OFF.

**Solid State Thermostat:**

Turn the I/O (ON/OFF) switch to the O (OFF) position

**Digital Control:**

Press and hold the \* button to turn the controller OFF.

*\*The specified button may appear slightly different than shown. Refer to the operator's manual for your appliance's specific control type to determine the exact appearance of each button and display.*

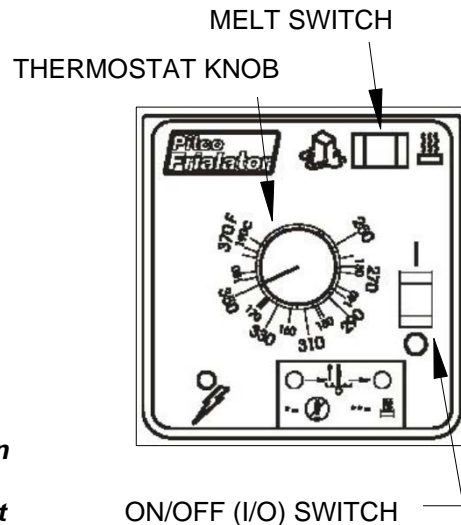

## 4.2. COMPLETE SHUTDOWN

1. Turn the temperature controller or thermostat OFF.

### Solid State Thermostat:

Turn the I/O (ON/OFF) switch to the O (OFF) position

### Digital Control:

Press and hold the \* button to turn the controller OFF.

***\*The specified button may appear slightly different than shown. Refer to the operator's manual for your appliance's specific control type to determine the exact appearance of each button and display.***

2. Turn the ON/OFF knob on the gas control valve clockwise to the OFF position.
3. The appliance is now completely shut down and can be cleaned if desired.

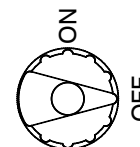

## 5. PREVENTATIVE MAINTENANCE

### 5.1. DAILY PREVENTATIVE MAINTENANCE

Performing the preventative maintenance steps below on a daily basis will keep your equipment safe and at peak performance. During the cooking process, oil/shortening may spill and splatter and requires immediate attention. Furthermore, during the cooking process, particles, crumbs and crackling collect inside the cook tank reducing product quality and decreasing oil/shortening life. If you are producing high quantities of fried food and/or frying heavily battered food, it may be necessary to perform these steps more than once a day.

#### **WARNING**

**Serious injury could result from direct contact with hot surfaces and/or oil. Always wear apron, heat resistant gloves for skin protection and goggles for eye protection**

#### 5.1.1. DAILY CLEANING

At least daily, filtering the oil is required. Make sure a clean filter is used every day. Using the cleaning brush, crumb scoop and clean out rod, remove all the loose debris.

#### 5.1.2. FILTERING WITH A FILTER DRAWER (IF EQUIPPED)

Refer to the following procedure to filter when the appliance is equipped with a filter drawer.

1. Turn the appliance OFF.
2. Remove drain line plug. (See page 12) CAUTION this will be very HOT after use.
3. Pull the blue drain handle down to drain oil/shortening from the cook tank into the filter pan.
4. Pull the red handle to turn the pump on to circulate oil/shortening through the filter media.
5. To refill the tank, lift the blue drain handle up and replace the drain line plug.
6. When the tank has completed filling, push the red handle to deactivate the pump.
7. Assure that the oil/shortening level is above the minimum level line. Additional oil may need to be added to the cook tank.
8. The oil/shortening in the cook tank has now been filtered.
9. Replace the filter media and clean the filter pan following the procedures mentioned in this manual.

#### 5.1.3. FLUSH HOSE OPERATION (IF EQUIPPED)

The cook tank can be rinsed cleaned by using a filter flush hose (if equipped). Refer to the following procedure to operate the filter flush hose.

1. Turn the appliance OFF.
2. Remove drain line plug. (See page 12) CAUTION this will be very HOT after use.
3. Pull the blue drain handle down to drain oil/shortening from the cook tank into the filter pan.
4. Connect the filter flush hose to the quick connecting fitting.
5. Point the filter hose nozzle outlet into the cook tank.

## PITCO FBG SERIES INSTALLATION & OPERATIONAL MANUAL

6. Pull the yellow handle to turn the pump on and allow oil/shortening to flow through the flush hose.
7. To refill the tank, lift the blue drain handle up and replace the drain line plug.
8. When the tank has completed filling, push the yellow handle to deactivate the pump.

### 5.1.4. REPLACING THE FILTER MEDIA (IF EQUIPPED)

Refer to the following procedure to replace the filter media if the appliance is equipped with a filter drawer.

1. Detach the pickup tube from the filter pickup assembly by unscrewing it (counterclockwise), at the knurled fitting, from the threaded fitting on the filter screen.
2. Slide off the filter paper clip and remove used filter paper from filter screen. Replace with new filter paper, ensuring that the hole in the paper is on the top, so that threaded fitting in filter screen protrudes through it.
3. Fold filter paper to the underside of the filter screen and replace filter paper clip.
4. Re-attach filter pickup tube to the filter screen by screwing it (clockwise) into the threaded fitting in filter screen.
5. Reinstall the filter pickup assembly into the filter system by placing the newly covered screen portion of the assembly into the filter pan and connecting the quick disconnect on the filter pickup assembly into white donut fitting on the left-hand side of the appliance. Ensure that it snaps tightly and securely into donut fitting.

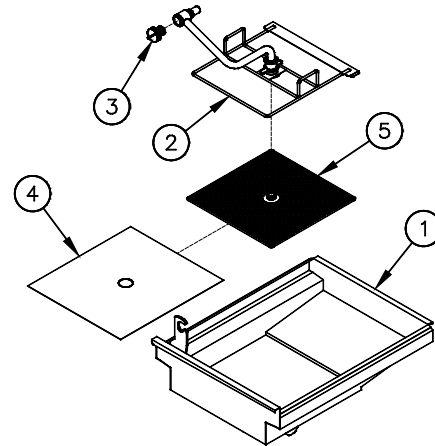

1. Filter Pan
2. Filter Pickup Assembly
3. Filter Strainer Cap
4. Filter Paper
5. Filter Screen

#### **WARNING**

The contents of the crumb catch and/or filter pan of any filter system must be emptied into a fireproof container at the end of the frying operation each day. Some food particles can spontaneously combust into flames if left soaking in certain oil/shortening materials.

#### **WARNING**

The power supply must be disconnected before cleaning and servicing this appliance!

### 5.1.5. APPLIANCE INSPECTION

- ✓ Check that the high temperature limit and temperature probe are in the correct position and secured in place. (Refer to the illustration on page 12 of this manual)
- ✓ Check that wires and cords are not frayed or loose in and out of the cabinet.
- ✓ Check around the appliance for loose parts or accessories that need to be secured or other foreign items (ex: Aerosol cans) that should be removed from the area.
- ✓ Check for oil/shortening leaks around the in and out of the cabinet and around the appliance.

#### **WARNING**

**DO NOT** leave the appliance unattended during cleaning.

#### **WARNING**

Serious injury could result from direct contact with hot surfaces and/or oil. Always wear apron, heat resistant gloves for skin protection and goggles for eye protection

#### **WARNING**

Read the operation section of this manual prior to filling or operating the appliance.

**5.1.6. CLEANING THE COOK TANK**

1. Following the procedure from 4.2. (COMPLETE SHUTDOWN) turn the appliance off. Remove the drain line plug. Drain all the oil/shortening from the tank and allow the tank to cool.
2. Remove the probe guard for cleaning. Clean the drain line plug. Do not bend or otherwise damage the probe or the high temperature limit bulb and its tube (Pictures, page 12)
3. Using the cleaning brush, remove all the loose debris and scrub all tank surfaces.
4. For tougher carbonized oil/shortening and carbon buildup scrub tank using a Scotchbrite or other abrasive pad. **DO NOT** use steel wool.
5. Wipe residue with a clean damp cloth and carefully dry any remaining oil/shortening droplets from the tank before returning oil/shortening into the tank.
6. Clean and dry drain line plug and probe guard before reinstalling.

**5.1.7. CLEANING THE CABINET**

1. Wipe any spilled oil/shortening, dust and lint from the cabinet exterior with a clean damp cloth and a mild food grade detergent. Be careful not to get any water or detergent in the oil/shortening. Use a nonabrasive pad for tougher stains if needed.
2. Remove detergent from all surfaces.
3. Cleaning the interior cabinet requires a clean cloth to remove any oil/shortening, dust, lint or filter powder (i.e.: Magnesol) from the interior of the cabinet.

**5.1.8. FILTER CLEANING (IF EQUIPPED)**

1. Unscrew filter strainer cap from pickup tube and gently tap it to dislodge any crumbs from the slots. Use a clean cloth to remove any remaining crumbs and reattach.
2. Scrape all loose debris and crumbs from filter pickup assembly and filter pan with the filter scoop shovel.
3. Remove filter pickup and place in pot sink, power soak sink or dishwasher for cleaning. Be sure to rinse thoroughly and dry all surfaces before re-assembly.
4. Wipe the filter pan with clean damp cloth and a food grade detergent. If necessary, place pan in pot sink to rinse all the detergent from the surfaces and dry all surfaces before re-assembly.

**5.2. WEEKLY PREVENTATIVE MAINTENANCE**

Performing the preventative maintenance steps above on a daily basis will keep your equipment clean and safe. On a weekly basis these additional steps should be performed.

1. Turn the fryer off. Allow the oil/shortening to cool to before pulling the fryer away from the hood. Hint: This maintenance may be ideal to perform on the day the oil/shortening is being changed so no oil/shortening is present in the tank or filter.
2. Disconnect the power cord(s), gas hose, and retention lanyard.
3. Wearing your protective gear, pull the fryer away from the hood.
4. Check that vent hood drip cup is empty and not dripping oil/shortening into the flue.
5. Check that the hood baffles are clean and not dripping oil/shortening into the flue.
6. Clean the fryer sides, back and the flue area, it may be necessary to use a non-abrasive pad to scour and a putty knife to scrape the oil/shortening buildup. With a clean damp cloth and food grade detergent wipe the area clean.
7. Wipe up any excessive oil/shortening on the power cord(s) and gas hose with a dry cloth.
8. Check flue pipe for any foreign debris/object and remove if found.
9. Reattach power cord(s), gas hose, retention lanyard and push fryer back under the hood.

### 5.3. MONTHLY PREVENTATIVE MAINTENANCE

Food debris and oil/shortening can build up inside the tank. Performing the monthly preventative maintenance steps below will keep your equipment safe and at peak performance. If you are producing high quantities of fried food and/or frying heavily battered food, it may be necessary to clean these components more than once a month.

#### 5.3.1. BOIL OUT PROCEDURE

Wear protective gloves and clothing when cleaning and draining the appliance. Oil/shortening may spatter and will cause injury to personnel.

1. Read the “operation” section of this manual prior to filling or operating the appliance.
2. Turn the appliance off. Remove the drain line plug. Drain all the oil/shortening from the tank and allow the tank to cool. The container must also be able to withstand 400°F (205°C) temperatures.
3. Remove the probe guard for cleaning. Clean the drain line plug. Do not bend or otherwise damage the probe or the high temperature limit bulb and its tube (Pictures, page 12)
4. Remove and discard any large debris inside the tank.
5. Close the drain valve and fill the tank with potable water to the level lines.
6. Place the appliance into boil mode:

**Models with Solid State Thermostat:** Put the thermostat into boil mode by flipping the power switch in the following order (I - O - I - O - I) within 3 seconds. The power (green LED) and heating (yellow LED) will be lit and the check (yellow LED) flashing.

**Models with Digital Control:** This controller does not have a boil mode. With the controller turned on, press the P key. If LOC displays, press the left timer twice and then the right timer twice. Press the P key two more times to show the set temperature. Use the down arrow to change the set temperature to 200°F (93°C). Hold the P key to save.

7. Once the water reaches a simmer, add 8 to 10 oz. (227 to 283 g) of Pitco cleaner for every 25 lbs. (11.3 kgs) of oil/shortening your fryer is rated to hold.
8. Simmer for 1 minute. (The water should never be allowed to boil as this may splash over the tank side and cause permanent damage to the components.)
9. Turn the appliance OFF and allow the fryer to soak for 15 to 30 minutes, allowing the cleaner to soften the oil/shortening deposits and carbon.
10. Scrub the inside of the tank using a cleaning brush safe for hot water. Care must be taken to remove all the foreign material on the tank, sidewalls and other components in the tank.
11. Drain the water from the tank.
12. Once the tank has cooled, rinse with clean potable water thoroughly.
13. Remove all remaining water and residue with a clean dry cloth.
14. Close the drain valve, dry and replace the drain line plug and probe guard then fill the cook tank with oil/shortening.

#### 5.3.2. TEMPERATURE CHECK

1. Use a high-grade pyrometer or digital thermometer suitable for temperature up to 380°F (193°C). Place the thermometer in the oil above the tip of the fryer’s temperature probe within 1” (2.54 cm). Be sure not to touch the tank since this will measure incorrect temperatures. Allow several minutes for the thermometer to equalize with the oil temperature.
2. Reference the following steps that apply to the appliance’s control type.

**Models with Solid State or Digital Controllers:**

Check that the controllers setpoint and thermometer is within  $\pm 5^{\circ}\text{F}$  ( $\pm 3^{\circ}\text{C}$ ). If your measurement is off, re-measure again before contacting an Authorized Service Company for further assistance.

**WARNING**

**The power supply must be disconnected before cleaning and servicing this appliance!**

#### 5.4. ANNUAL/PERIODIC PREVENTATIVE MAINTENANCE AND INSPECTION

This section should ONLY be performed by a qualified service technician as part of a regular kitchen maintenance program. This inspection should take place a minimum of once a year by an Authorized Service Technician recommended by Pitco. It may be necessary perform this inspection more than once a year.

##### 5.4.1. SAFETY EVALUATION

- ✓ Check power cord and plug.
- ✓ Check all exposed wiring connections, switches, and indicator lights.
- ✓ Check legs, casters, wheels, plate welds and ensure all nuts and bolts are secured.
- ✓ Check conditions of flexible gas line and verify appliance retention / lanyard system is in place.

##### 5.4.2. MECHANICAL INSPECTION

- ✓ Check frypot for shortening leaks and excessive oil build up
- ✓ Check for oil migration (Clean as required)
- ✓ Check hood drain cup, ensure it is empty and not dripping into the flue.
- ✓ Check hood baffle for clean surface, oil/water condensate can drip on and into the flue.
- ✓ Check flue for foreign debris and hood down draft currents.
- ✓ Check drain/filtration system (if equipped) for leaks
- ✓ Check for missing appliance parts, i.e.: cover strips
- ✓ Check for missing fasteners

##### 5.4.3. TEMPERATURE CONTROL SYSTEM

- ✓ Check electrical connections and harnesses
- ✓ Check temperature probes and limits for carbon build up and plating. Clean as required
- ✓ Check proper mounting of probes and sensors and all fasteners are secure.
- ✓ Check thermistor probe resistances for stability.
- ✓ Check DVI Drain Valve Interlock drops out controller.
- ✓ Check Controller/thermostat features to ensure they are functioning.
- ✓ Check Temperature Calibration

##### 5.4.4. FILTER SYSTEM (IF EQUIPPED)

- ✓ Check electrical connections and harnesses.
- ✓ Check IEC power cords are fully engaged and secure.
- ✓ Check for any air or shortening leaks and for excessive oil build-up.
- ✓ Check O-Ring on filter pickup tube and replace as needed.
- ✓ Check filter strainer on pickup tube.
- ✓ Check operation of drain valve and DVI drain valve interlock.
- ✓ Check operation of return oil valve and its pump switch.
- ✓ Check operations of flush hose quick disconnect (if equipped), clean as needed.
- ✓ Check all hardware in filter pan.
- ✓ Check filter operation by filtering the appliances.
- ✓ Check pump motor amp draw compare to nameplate amperage.
- ✓ Check pump and motor, clean any excess oil from pump assembly.
- ✓ Check all filter hoses for leaks and integrity.

##### 5.4.5. GAS COMBUSTION SYSTEM

- ✓ Check for gas leaks.
- ✓ Check and clean vent tube on gas control valve pressure regulator.
- ✓ Check burners, clean debris and grease from pilot and pilot orifice tips.

## PITCO FBG SERIES INSTALLATION & OPERATIONAL MANUAL

- ✓ Check and adjust burner pressure to nameplate reading.
- ✓ Check incoming gas pressure when all gas appliances are on.
- ✓ Check ignition system and adjust pilot flame as required.
  - Check flame sensor reading.
  - Check gap spacing and clean igniter.
- ✓ Recheck for gas leaks after inspection.

### 5.5. VENTILATION HOOD

Proper ventilation hood operation is very important for the correct operation of this appliance and the safety of personnel. The ventilation hood should be inspected at the time of installation of this appliance to ensure that it will operate properly in conjunction with the appliance. A regular schedule of examination, in accordance with ANSI/NFPA 96 latest edition and/or local codes must be followed.

## 6. TROUBLESHOOTING

### 6.1. POWER FAILURE

If electric power is removed for any reason, the appliance will shut down.

Wait five minutes after the power is restored before attempting to restart the appliance. This will allow time for any gas that may have accumulated in the burner or tank jacket to dissipate.

To restart the appliance, follow the appliance start up procedure in section 3 "APPLIANCE START UP".

#### CAUTION

**DO NOT attempt to operate this appliance during a power outage.**

### 6.2. HIGH TEMPERATURE LIMIT SWITCH

This appliance is equipped with a high temperature limit switch. The high temperature limit switch will stop the appliance from functioning if the oil temperature in the cook tank reaches an unsafe temperature. In the event that the high temperature limit has tripped, please refer to the following procedure to reset the switch.

- a. Turn the appliance off.
- b. Allow the appliance ample time to cool to room temperature.
- c. Add oil/shortening to the cook tank as needed.
- d. Press the high temperature reset button.
- e. The high limit switch is now reset and the appliance is ready for startup.

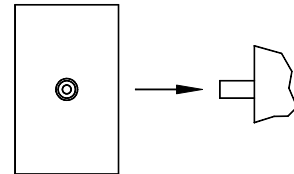

#### WARNING

**DO NOT add oil/shortening to the tank until it has been given ample time to cool down. Failure to do so may result in damage to the appliance and/or injury to the operator.**

### 6.3. DRAIN VALVE INTERLOCK (NOT ON ALL MODELS)

If your appliance is equipped with a drain valve interlock circuit, the appliance will stop heating if the tank drain valve is opened. In some cases, the appliance will turn off. Refer to the following procedure to resume operation after the drain valve interlock is tripped.

1. Turn the appliance OFF (if not already OFF).
2. Close the tank drain valve and fill the tank with oil/shortening.
3. Turn the appliance ON.



6.4. TROUBLESHOOTING CHARTS

6.4.1. APPLIANCE TROUBLESHOOTING CHART

<b>Problem</b>	<b>Probable Causes</b>	<b>Corrective Actions</b>
Controller does not activate.	No power to appliance.	Check main building power supply.
	Controller not turned on.	Turn on controller.
	Power Cord loose or not connected.	Connect power cord.
	Main circuit breaker to appliance has tripped.	Reset circuit breaker
	Appliance fuse has blown.	Contact Authorized Service Company.
Controller is on and appliance will not heat up.	High temperature limit has tripped.	Allow appliance to cool and reset High temperature limit.
Appliance will not maintain temperature properly.	Faulty temperature probe.	Contact Authorized Service Company.
	Faulty High temperature limit.	Contact Authorized Service Company.

6.4.2. FILTER TROUBLESHOOTING CHART (IF EQUIPPED)

<b>Problem</b>	<b>Probable Causes</b>	<b>Corrective Actions</b>
Filter pump does not activate.	Filter pump circuit breaker has tripped.	Reset circuit breaker.
Oil/shortening is returning to the tank slowly or not at all.	Dirty filter paper	Change filter paper.
	Strainer cap dirty	Remove strainer cap and clean.
	Filter pan not pushed in completely.	Push filter pan in.
Excessive air bubbles are in the oil being returned to the tank.	Pickup tube screen not tight.	Tighten pickup tube screen cap.
	Pickup tube screen cap missing	Locate and install pickup tube screen cap.
	Filter pan not pushed in completely	Push filter pan in to complete connection.
	Improperly adjusted or defective drain switch.	Contact Authorized Service Company.

6.5. OVERALL DIMENSIONS AND WEIGHTS

Model	Cooking Area Length	Cooking Area Depth	Overall Height	Overall Width	Overall Depth	Shipping Weight
FBG 18	18 x 24 in. (45.7 x 61 cm)	3-1/4 - 5 in (8.3 - 12.7 cm)	43.125 in (109.5 cm)	20.0 in (50.8 cm)	34.5 in (87.6 cm)	270 lbs. (122.5 kg)
FBG 24	24 x 24 in (61 x 61 cm)	3-1/4 - 5 in (8.3 - 12.7 cm)	43.125 in (109.5 cm)	26.0 in (66.0 cm)	34.5 in (87.6 cm)	315 lbs. (142.9 kg)

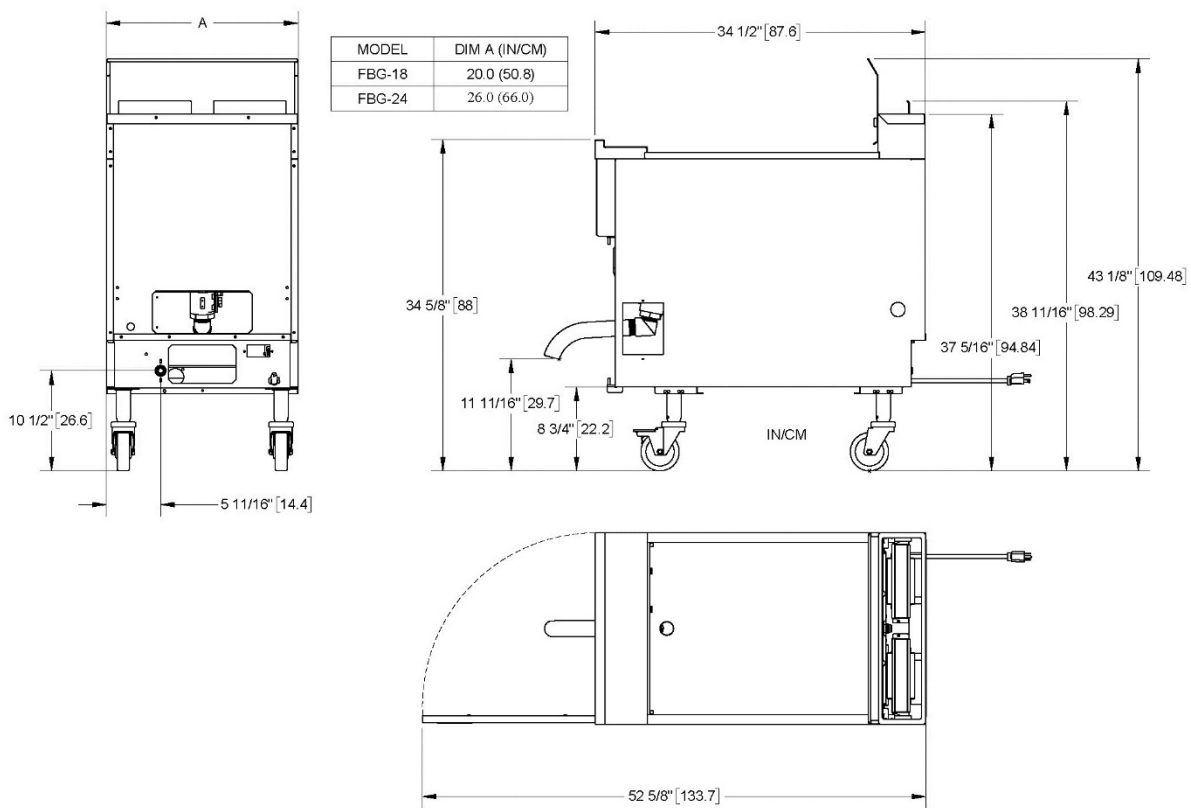

INTENTIONALLY LEFT BLANK



## Original Instructions

Annual service to this appliance by an authorized person is recommended. Do not modify this appliance: servicing must only be carried out by an authorized person. For service and parts, minor adjustments, fault finding, or if this appliance cannot be adjusted to operate correctly, contact:

In the event of problems with or questions about your order, please contact the Pitco Frialator factory at: (603) 225-6684 World Wide Website Address: <a href="http://www.pitco.com">www.pitco.com</a>	In the event of problems with or questions about your equipment, please contact the Pitco Authorized Service and Parts representative (ASAP) covering your area, or contact Pitco at the numbers listed to the left.
---	--

MAILING ADDRESS – P.O. BOX 501, CONCORD, NH 03302-0501 SHIPPING ADDRESS – 39 SHEEP DAVIS RD, PEMBROKE, NH 03275
--