

INSTRUCTIONS AND PARTS LIST

PITCO-MATIC FILTER SYSTEMS

PITCO FRIALATOR, INC.

POST OFFICE BOX 501

CONCORD, NEW HAMPSHIRE 03302-0501

TEL: (603) 225-6684

FAX: (603) 225-8497

► **WARNING:** At operating temperature, the shortening in the fryer may be hotter than 375°F (190°C). This hot, melted shortening can cause you to be burned very badly. Do not let the hot shortening touch your skin or clothing. Always wear insulated oil-proof gloves when filtering.

FILTERING INSTRUCTIONS - MOBILE UNITS

**Filter the fryer twice daily for best results.
Filter while the oil is hot.**

1. Turn the fryer off before you drain and filter the oil.
2. Pull the filter pan out on the carriage slide. Prepare the filter pan as follows:
 - Place the paper support rack (item 17) in the bottom of the pan.
 - Place the paper (item 14) on top of the support rack. Use a new piece of paper if the old paper is dark, scuffed, or torn.
 - Place the paper retainer rack (item 18) in the pan. Place the rack so the support rod for the flush nozzle sits in the front right corner of the pan.
 - Add the precoat (“diatomaceous earth”) on top of the paper:

Model 7	6 oz.
Model 12	6 oz.
Models 14/14B/14R	12 oz.
Model 18	16 oz.
Model 24	32 oz.
Model 34	32 oz.

(measured by volume)
3. Securely connect the filter pan hose (item 16) to the inlet fitting on the filter. Use the quick-disconnect. Install the extension (item 4) on the drain nipple.
4. Connect the flush hose to the outlet fitting. Use the quick-disconnect. Place the end of the hose nozzle over the holding rod in the filter pan.
5. Now you are ready to begin filtering. With the pan under the drain extension, open the drain valve (green handle). Drain the oil into the filter pan.
6. Hold the nozzle in the bottom of the fryer. Turn the filter switch on. Wash all of the debris from the sides of the fryer and down the drain. When the kettle is clean, turn the filter switch off and close the drain valve (green valve). Return the nozzle to the holding rod on the filter pan.

7. With the nozzle on the holding rod, circulate the oil through the filter. Turn the filter switch on for about two minutes to circulate the oil.

8. Return the oil to the fryer. Turn the filter switch off, place the nozzle in the kettle, and turn the filter switch on again. The pump will return the filtered oil to the kettle. After all the oil has been returned to the fryer, turn the filter switch off. Return the nozzle to the holding rod in the filter pan. The fryer is ready to be put back into service.

9. If you are going to filter another fryer at this time, scrape up the debris from the filter paper. Add another 6 oz. of precoat (measured by volume) for the next fryer. (If you filter any more fryers during this session, add another 6 oz. each time you begin to filter one of these fryers.) For each fryer, repeat steps 6, 7 and 8. Change the filter paper when it becomes dark, scuffed, or town.

10. When you are finished filtering, remove the flush line hose. Disconnect the flush hose from the outlet fitting and drain the hose into the filter pan. Disconnect the filter pan hose from the inlet fitting and drain the hose into the filter pan. Scrape the debris off of the filter paper.

11. Remove the filter paper retainer rack, the used filter paper, and the filter paper support rack. The filter pan can then be removed for cleaning. Clean pump and dolly assembly by wiping down the unit with a damp cloth.

► CAUTION

DO NOT PUMP WATER THROUGH THE FILTER PUMP SYSTEM. THE PUMP FUNCTIONS USING THE LUBRICATION OF THE OIL AND USING WATER WILL CAUSE DAMAGE TO THE PUMP.

► WARNING

DO NOT ATTEMPT TO LIFT FILTER MACHINE OFF FLOOR FOR CLEANING. BODILY INJURY MAY OCCUR.

(In the event water gets into the piping of the filter unit, it must be drained out. With the unit broken down for cleaning, tip pan towards intake piping and gently raise hose so fluid drains into pan, and then remove fluid from pan.)

► **WARNING:** At operating temperature, the shortening in the fryer may be hotter than 375°F (190°C). This hot, melted shortening can cause you to be burned very badly. Do not let the hot shortening touch your skin or clothing. Always wear insulated oil-proof gloves when filtering.

FILTERING INSTRUCTIONS - BUILT IN UNITS

**Filter the fryer twice daily for best results.
Filter while the oil is hot.**

1. Turn the fryer off before you drain and filter the oil.
2. Pull the filter pan out on the carriage slide. Prepare the filter pan as follows:
 - Place the paper support rack (item 17) in the bottom of the pan.
 - Place the paper (item 14) on top of the support rack. Use a new piece of paper if the old paper is dark, scuffed, or torn.
 - Place the paper retainer rack (item 18) in the pan. Place the rack so the support rod for the flush nozzle sits in the front right corner of the pan.
 - Add the precoat (“diatomaceous earth”) on top of the paper:

Model 7	6 oz.
Model 12	6 oz.
Models 14/14B/14R	12 oz.
Model 18	16 oz.
Model 24	32 oz.
Model 34	32 oz.

(measured by volume)
3. Securely connect the filter pan hose (item 16) to the inlet fitting on the filter. Use the white quick-disconnect.
4. If the unit has a flush hose, connect the flush hose to the outlet fitting. Use the black quick-disconnect. Place the end of the hose nozzle over the holding rod in the filter pan.
5. Now you are ready to begin filtering. With the pan under the drain line elbow, open the drain valve (green handle). Drain the oil into the filter pan.
 - 6a. If the unit has a flush hose, hold the nozzle in the bottom of the fryer. Turn on the flush hose valve (yellow handle) and turn the filter switch on. Wash all of the debris from the sides of the fryer and down the drain. When the kettle is clean, turn the filter switch off and close the drain valve (green handle). Return the nozzle to the holding rod on the filter pan. Close the flush hose valve.

- 6b. If the unit does not have a flush hose, open the return valve (red handle), and turn the filter switch on. Scrub down the sides of the kettle until it is clean. Use the brush and the filtered oil being returned into the fryer. When the kettle is clean, turn the filter switch off. Close the drain valve (green handle) and the return valve (red handle).
7. Circulate the oil through the filter. To do this, open the flush line valve (blue handle). Turn the filter switch on for about two minutes to circulate the oil.
8. Return the oil to the fryer. After two minutes, open the return valve (red handle) and close the flush line valve (blue handle). Leave the filter switch on. The pump will return the filtered oil to the kettle. After all the oil has been returned to the fryer, turn the filter switch off. Close the return valve (red handle). The fryer is ready to be put back into service.
9. If you are going to filter another fryer at this time, scrape up the debris from the filter paper. Add another 6 oz. of precoat (measured by volume) for the next fryer. (If you filter any more fryers during this session, add another 6 oz. each time you begin to filter one of these fryers.) For each fryer, repeat steps 6, 7 and 8. Change the filter paper when it becomes dark, scuffed, or town.
10. When you are finished filtering, remove the flush line hose, if the unit has one. Disconnect the flush hose from the outlet fitting and drain the hose into the filter pan. Disconnect the filter pan hose from the inlet fitting and drain the hose into the filter pan. Scrape the debris off of the filter paper.
11. If you are using solid shortening, open the circulating valve (blue handle) and the flush valve (yellow handle) if the unit has this valve. Do this for one minute to drain the oil from the system.
12. Remove the filter paper retainer rack, the used filter paper, and the filter paper support rack. The filter pan can then be removed for cleaning.

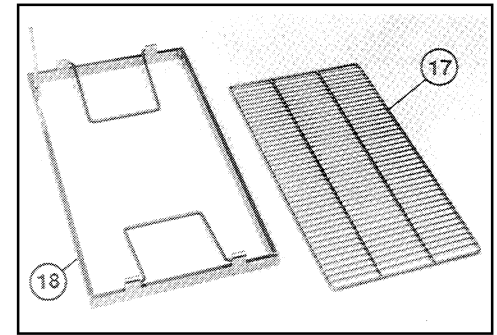
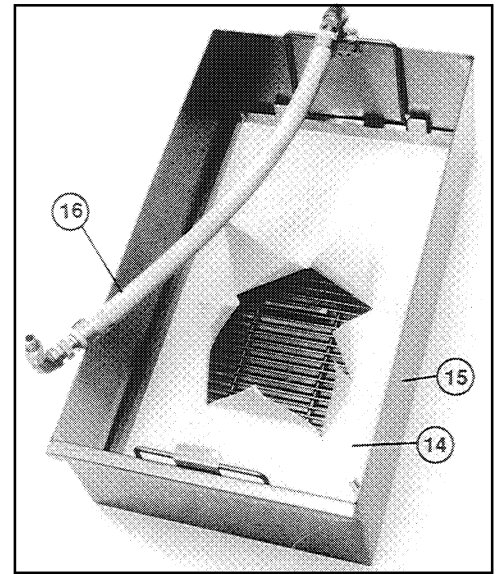
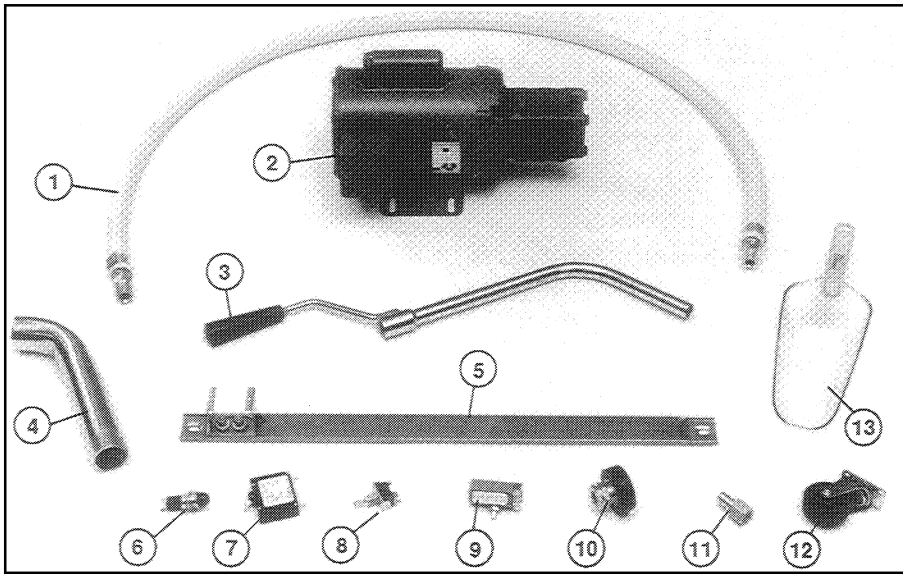

PARTS LIST

ITEM NO	PART DESCRIPTION	PITCO MODEL	PART NUMBER
1	Flush hose w/threaded end fitting	All	B7406407
2	Pump and motor assembly	All	P5046381
3	Nozzle w/handle bracket only	All	B7406301
	Handle only, black, for nozzle	All	P6071190
4	Drain nipple extension, 1 1/4"	Mobile units only	A2510101
5	Heaters, 115V AC, two needed	All	P5046980
6	Light base	All	P5045010
	Light bulb	All	P5045030
	Light lens, red	All	P5046326
7	Circuit breaker	All	P5045217
8	Pump switch	All units w/o heater	P5047162
	Pump and heater switch	All units with heater	P5047163
9	Pressure hose valve	All	P6071480
10	Quick disconnect, female, black ring	All	B7402241
	Quick disconnect, female, white ring	All	B7402240
11	Quick disconnect, male	All	P6071123
12	Casters	Mobile units only	P6071062
13	Cleaning scoop	All	P6071369
14	Filter paper, 13 1/2" x 24"	P14	P6071371
	Filter paper, 17 1/2" x 28"	P18-34	P6071373
15	Filter pan	P14	B7403601
		P18	B7403701
		PE18B	B7403702
		P24	B7403801
		P34	B7403802
16	Filter pan inlet hose	14Bl	B7406402
		18Bl	B7406403
		Mobile units	B7406404
17	Filter paper support rack	P14	P6072611
		P18-34	P6072612
18	Filter paper retainer rack	P14	B6603001
		P18	B6603002
		P24	B7412405
		P34	B7412406
		E18B-20-26	B7412404

NOT SHOWN:

Measuring cup	All	P6071368
Precoat or diatomaceous earth, 50 lbs. ...	All	P6071396