

Pro-Max[®] 2.0

MODEL

7" Tabletop
Two-Sided Grill

Electronic Controls

TWO SIDED GRILLS INSTALLATION INSTRUCTIONS



These symbols are intended to alert the user to the presence of important operating and maintenance instructions in the manual accompanying the appliance.



Go to:
www.star-mfg.com/scripts/manuals.aspx
to obtain this units installation & operations manual
along with other documents.

NOTICE

Using any part other than genuine Star factory supplied parts relieves the manufacturer of all liability.

Star reserves the right to change specifications and product design without notice. Such revisions do not entitle the buyer to corresponding changes, improvements, additions or replacements for previously purchased equipment.

Due to periodic changes in designs, methods, procedures, policies and regulations, the specifications contained in this sheet are subject to change without notice. While Star Manufacturing exercises good faith efforts to provide information that is accurate, we are not responsible for errors or omissions in information provided or conclusions reached as a result of using the specifications. By using the information provided, the user assumes all risks in connection with such use.



CAUTION

GENERAL SAFETY INFORMATION

This equipment is designed and sold for commercial use only by personnel trained and experienced in its operation and is not sold for consumer use in and around the home nor for use directly by the general public in food service locations.

Before using your new equipment, read and understand all the instructions & labels associated with the unit prior to putting it into operation. Make sure all people associated with its use understand the units operation & safety before they use the unit.

All shipping containers should be checked for freight damage both visible and concealed. This unit has been tested and carefully packaged to insure delivery of your unit in perfect condition. If equipment is received in damaged condition, either apparent or concealed, a claim must be made with the delivering carrier.

Concealed damage or loss - if damage or loss is not apparent until after equipment is unpacked, a request for inspection of concealed damage must be made with carrier within 15 days. Be certain to retain all contents plus external and internal packaging materials for inspection. The carrier will make an inspection and will supply necessary claim forms.

GENERAL INSTALLATION INFORMATION

The unit time and temperature are preset by the factory to the customer requirements. If adjustments are required, refer to the time or temperature programming sections in this manual.

INSTALLATION

1. Plug unit into dedicated receptacle, see nameplate for voltage requirements.
2. **DO NOT** plug into incorrect voltage line. Doing so will damage the unit and void the warranty.
3. Each unit has been properly wired and inspected at the factory for operation on the voltage specified on the nameplate.
4. **DO NOT** operate without burn guards (Certian units only).



WARNING

**DO NOT CONNECT TO ANY OTHER
TYPE OF CURRENT OR THE MACHINE
WILL BE SERIOUSLY DAMAGED.**

MAINTENANCE AND REPAIRS

Contact the factory, a service representative or a local service company for service or required maintenance. Go to www.star-mfg.com to find a service agent near you. Replacement cord sets must be purchased from Star Manufacturing International, Inc. or our authorized agents.

Should you need any assistance regarding the operation or maintenance of any Star equipment; write, phone, fax or e-mail our service department. In all correspondence mention the model number and the serial number of your unit, along with the voltage.

Business Hours: 8 am to 4:30 p.m. Central Standard Time

Telephone: (800) 264-7827

Fax: (314) 781-2714

E-mail: Parts@star-mfg.com
Service@star-mfg.com
Warranty@star-mfg.com

Website: www.star-mfg.com

Mailing Address: Star Manufacturing International Inc.
265 Hobson St.
Smithville, TN 37166
U.S.A.

ALL UNITS

Initial Start Up

Level unit using the adjustable feet under the unit (approximately 1/2" adjustment).

Before using the unit for the first time, clean and heat for approximately 45 minutes. The grill may emit a small amount of smoke as the cooking surfaces reach 300-350°F. Do not be alarmed, as the smoke is caused by oils associated with the manufacturing process and will stop when the grill reaches 400°F. Best to do this in a well ventilated area.

Seasoning The Cooking Surfaces

First Time Seasoning

Follow your company/corporate guidelines for seasoning cooking surfaces or:

1. Bring the grill to 275°F by placing the unit in "CLN" mode by pressing the "TEMP" button and button's 2 & 3 for 3 seconds.
2. Wait for unit to reach 275°F (press the "TEMP" button to display units current temperature).
3. Brush the cooking surfaces with a SALT-FREE release agent. If using an aerosol agent, first apply into a cup and then brush onto cooking surface.
4. Let sit for 20 minutes, and then wipe clean using a warm damp cloth.
5. To Exit "CLN" mode, turn unit "OFF" then "ON" or press any of the four (4) program buttons.

Daily Seasoning

The grill should not require much seasoning while in use. In most cases, brush a light coating of a **SALT-FREE** baking release agent in the morning and occasionally throughout the day will be enough to prevent any sticking. It is not necessary to spray before grilling each item.

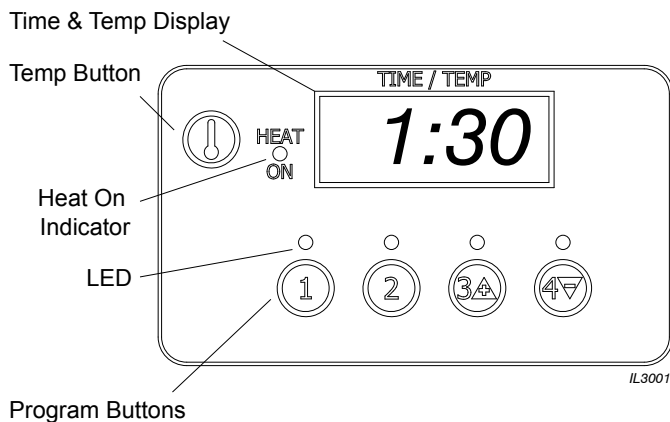

ELECTRONIC TEMP CONTROL OPERATION

Operating Instructions

1. Turn the unit on by placing the switch in the ON position. The HEAT ON indicator, Time & Temp Display & the LED indicator will flash until it reaches operating temperature. Initial startup heating time is approximately 30 minutes. When the unit reaches operating temperature, the heat indicator LED will turn off and the program LED and the Time & Temp Display will stop flashing.
2. Place product on the cooking surface of the unit and close the lid.
3. Press the PROGRAM button to start the timer, the LED light above the button will "FLASH" and the displayed time will count down to "0" at which time the unit will display "done" and beep. To turn off the beeper, press the PROGRAM button again.
4. To CANCEL a program during the cooking process, press and hold the PROGRAM button for 5 seconds.
5. Raise the lid and remove the food product. Using a spatula, scrape residue into the grease catcher tray.
NOTE: Metal utensils may be used; however, using nonmetal utensils will prolong the life of the cooking surface.
6. Turn the unit off when it is not in use.

Using Multiple Timers:

1. Place product on the cooking surface and close the lid.
2. Press the (1st) PROGRAM button to start the timer, the LED light above the button will "FLASH" and the displayed time will begin counting down.
3. Place second product on the cooking surface and close the lid.
4. Press the (2nd) PROGRAM button to start the second timer, the 1st LED will change from flashing to solid, and the 2nd LED will be flashing. The time countdown will be for the program with the flashing LED indicator.
5. Pressing the (1st) PROGRAM button will change that LED indicator back to flashing and the countdown display will represent this program button. The LED indicator for the (2nd) program will change from flashing to solid.
6. When the (1st) program is completed, "done" will be displayed and an alarm will sound. The display will change to the remaining time on the (2nd) program and that programs LED indicator will change to flashing.
7. When the (2nd) program is completed, "done" and an alarm will sound. The countdown time for the last program selected will be displayed and that programs LED indicator will remain solid.

Temperature:

You can view the unit's actual temperature by pressing the temp button.

TO PROGRAM TIME AND TEMPERATURE:

1. Press and hold TEMP (actual temperature displays).
2. While holding TEMP, press and hold any program button on the left for one second. The LED above the program number will light and the display will read "____." Enter the four-digit security code sequence: 4, 3, 2, 1. The security code will not show on the display. Once the correct sequence has been entered, the preset time will be displayed and the LED for that program will begin to flash.
3. Set the desired time with the "3" increase or "4" decrease buttons.
4. **Press** the TEMP button to save the time.
5. The bottom and top temperature settings can now be programmed.
6. The bottom temperature setting for the selected switch will now be displayed.
7. Change the bottom temperature setting using "3" increase or "4" decrease. **Press** the "TEMP" button when the desired setting is displayed.
8. The top temperature setting for the selected switch will now be displayed.
9. Change the top temperature setting using "3" increase or "4" decrease. **Press** the "TEMP" button when the desired setting is displayed.
10. **Press** any other program button within 15 seconds to continue programming without re-entering the security code.

ALL UNITS

Cleaning

Begin the cleaning procedure by following your corporate guidelines, or follow the steps below.

NOTE: COOKING SURFACES ARE HOT AND CAUTION MUST BE TAKEN.

1. Flip the rocker switch on the front of the unit to the "OFF" position.
2. Wait for the unit to cool below 275°F, before continuing.
3. Scrape cooking surfaces with a spatula to remove any loose food debris
4. If using a carbon cleaning agent (safe for aluminum or cast iron) follow those instructions.
5. Using a mixture of 1/2 tablespoon dish detergent & 1/2 cup warm water.
6. Pour 1/4 cup of above cleaning solution onto the bottom cooking surface.
7. Immediately spread cleaning solution around the surface with cleaning pad. Use moderate pressure to scrape away burnt-on food.
8. Apply cleaning solution to cleaning pad.
9. Use moderate pressure to scrape away burnt-on food on top cooking surfaces.
10. Drain cleaning solution to grease trap.
12. Wipe off remaining cleaning solution with thick damp cloth until clean.
13. Empty and clean grease catcher cup as required using detergent and water after removing cup from unit.
14. Reseasoning the grill cooking surfaces by following the Daily Seasoning procedures.
15. To Exit "CLN" mode, turn unit "OFF" then "ON" or press any of the four (4) program buttons.

NOTE: It is best not to let food cook onto the grill, as food build-up on the grill will increase sticking and smoking. In addition, carbon may build up on the grill surface and reduce the cooking efficiency.

Carbon Buildup: A black matter that forms on or near the cooking surface. Generally this is a combination of: releasing agents, oils, food particles etc., that have cooked to the surface. After a period of time without cleaning, this will reduce performance and material may start flaking off. When that happens, follow the "Carbon Cleaning" procedures.

Carbon Cleaning

When carbon build up occurs, use a carbon removal agent (safe for aluminum surfaces) according to the instructions provided with the cleaner. When this process is complete, you must re-season the grill according to your company/corporate guidelines, or the seasoning instructions in this manual.



CAUTION

DO NOT IMMERSE OR LET THE UNIT STAND IN WATER.

DO NOT HOSE DOWN THE UNIT OR THE TABLE/COUNTER IF THE UNIT IS ON THE TABLE/COUNTER.

KEEP AWAY FROM RUNNING WATER.

DO NOT USE SHARP OBJECTS TO REMOVE CARBON BUILD-UP.

DO NOT USE ICE ON THE COOKING SURFACE!

BEFORE CLEANING MAKE SURE POWER IS TURNED OFF, UNIT IS UNPLUGGED AND IS NOT TOO HOT.

Apply only cleaners which are safe for aluminum and iron surfaces.

DO NOT SPLASH FRONT CONTROL PANEL!

DO NOT SPLASH FLEX CONDUIT CONNECTING TOP AND BOTTOM OF THE UNIT.

PST7E; Sandwich Grill

Model: PGT7E Platten Assemblies

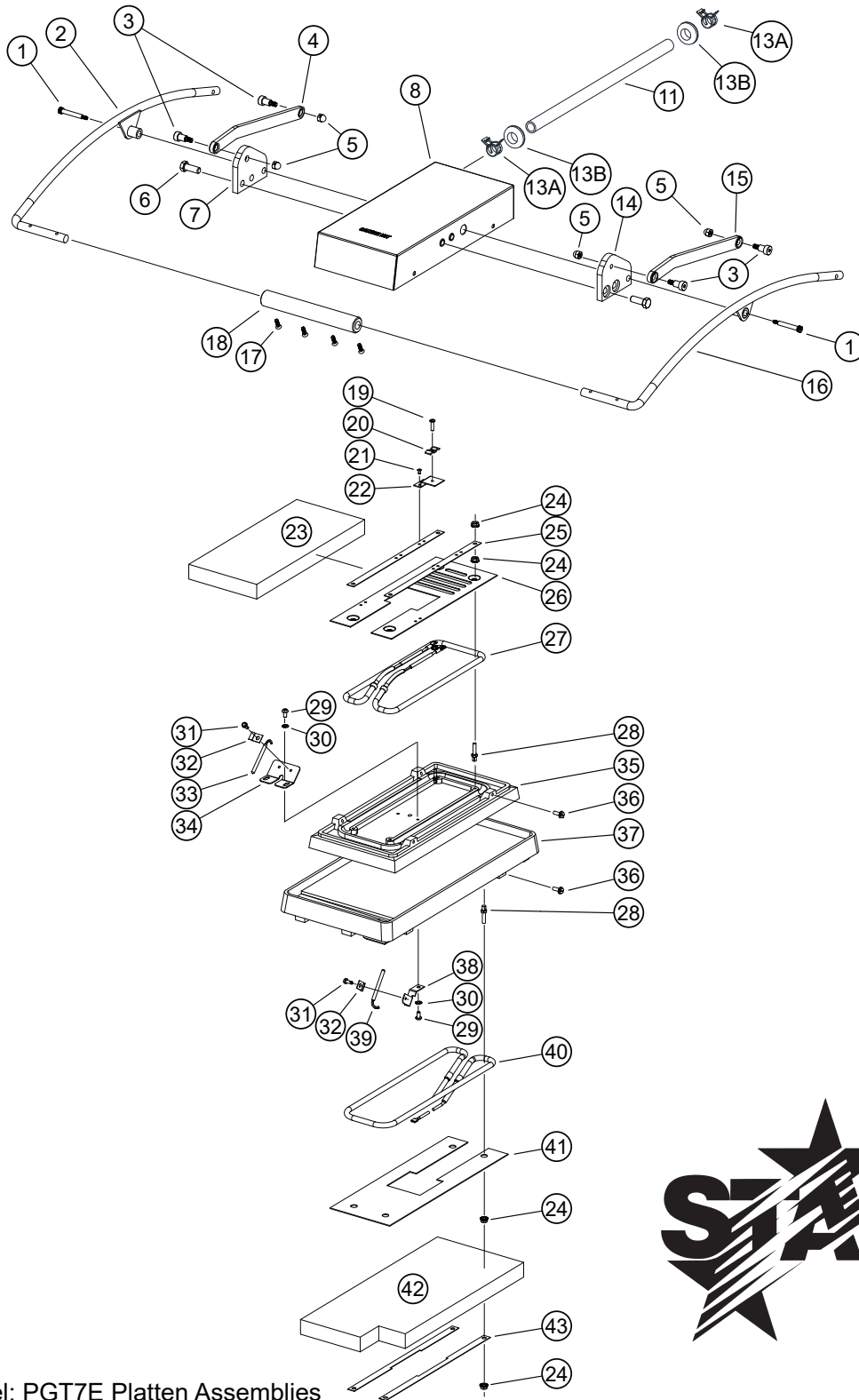

SK2844

Rev. A

12/1/2020

2M-Z21042: Pro-Max 2.0 7-inch Two Sided Toaster

PARTS LIST

(10-22)

Model: PGT7E Platten Assemblies				
Fig. No	Part Number	Qty	Description	Application
1	2C-Z18300	2	SCR,SHLDR,SS,3/8 DIA.X1.0	
2	2B-Z19515	1	ARM,RIGHT,7 IN.	
3	2C-Z18751	4	SCR,SHLDR,SS,3/8 DIA.X.50	
4	D9-GR0650	1	LINK AY., LEFT	
5	2C-Z18752	4	LOCKNUT, ACORN,1/4-20,SS	
6	2C-37498	4	BOLT HEX 3/8-16 X 1 SS	
7	2V-Z18468	1	PLATE, LIFTING, LEFT SIDE	
8	* D9-GR0858	1	WELD AY., TOP HOUSING,7	PST7E-CH, PGT7ESW
11	* D9-Z23245	1	CONDUIT, 1/2" I.D. X 15" LONG	
13A	* 2C-Z23149	2	SPRING CLAMP, 21/32" I.D.	
13B	* 2I-Z23148	2	GROMMET, 11/16" I.D.	
14	2V-Z18311	1	PLATE,LIFTING,RIGHT SIDE	
15	D9-GR0651	V1	LINK AY., RIGHT	
16	2B-Z19514	1	ARM,LEFT.7 IN.	
17	2C-Z18749	4	SCREW,SS,10-32X625 PH FHD	
18	2V-Z19512	1	HANDLE,7 IN.	
19	2C-2853	1	SCREW #8X5/8 A THP STL NP	
20	B9-04-WB-0046	1	CLAMP WIRE SUPPORT	
21	2C-Y1451	2	RIVET 1/8 x .337 MORISON	
22	D9-Z13012	1	WIRE MOUNT	
23	D9-Z2133	1	INSULATION FIBERGLAS TOP	
24	2C-Z2893	16	NUT 10-24 HEX STL ZP	
25	D9-Z13013	2	BRACKET, INSULATION HOLD	
26	D9-Z13011	1	PLATE-TOP ELEMENT RET.	
27	PS-Z9325	1	ELEMENT HEATING TOP 500W	120V
	PS-Z9326		ELEMENT HEATING TOP 500W	230V, 240V, UK
28	2C-08-07-0285	8	SCREW 10-24X3/4X3/8 TYPE	
29	2C-1512	3	SCREW 10-24X3/8 RHP STL	
30	2C-1827	3	WASHER #10 EXT STL NP	
31	2C-8833	2	SCREW 8-18X1/2 HEX STL NP	
32	2C-Z3350	1	HALF CLAMP .188 D STL ZP	
33	2E-Z3278	1	RTD PROBE - 60" LONG WIRE	
34	D9-Z3903	1	BRACKET, PROBE MOUNT	
35	PS-GR0356	1	KIT, 2F-Z3237 TOP CASTING, SMOOTH	PST7E
	PS-GR0355		KIT, 2F-Z5615 TOP CASTING, GROOVED	PST7EGT, PGT7
	2F-Z7967		CASTING, IRON, TOP, GR.-SPT	PGT7I
	2F-Z8349		CASTING, IRON-TOP SMTH SPT	PST7I
36	2C-Z5883	8	10-24 X 1/2 FZA SCREW	
37	2F-Z17103	1	CASTING,BTTM,SMOOTH,AL,7	PST7
	2F-Z17104		CASTING,BOTTOM GRV ALUM	PGT7
	2F-Z19221		CASTING, BTM,GROOVE,IRON 7	PGT7I
	2F-Z19220		CASTING,BTM,SMOOTH,IRON,7	PST7I
38	D9-Z19534	1	BRACKET,PROBE,BOTTOM,7	
39	2E-Z1470	1	SNSR-RTD,2K OHM,24"LDS	
40	2N-Z17082	1	ELEMENT,925W,120V,7 BTTM	120V
	2N-Z19546		ELEMENT,925W,240V, 7 BTTM	230V, 240V, UK
41	D9-Z12012	1	PLATE, BOTTOM ELEMENT	
42	D9-Z19424	1	INSULATION,7,BOTTOM	
43	D9-Z12885	2	INSULATION HOLD DOWN,	
NI	2V-Z20067	1	SCRAPER, GROOVED, HARDWOOD	

* Units before 08/05/2019

REFER TO MANUAL PST7E DATE 1/28/2016

2M-Z21042: Pro-Max 2.0 7-inch Two Sided Toaster

PGT7E; Sandwich Grill

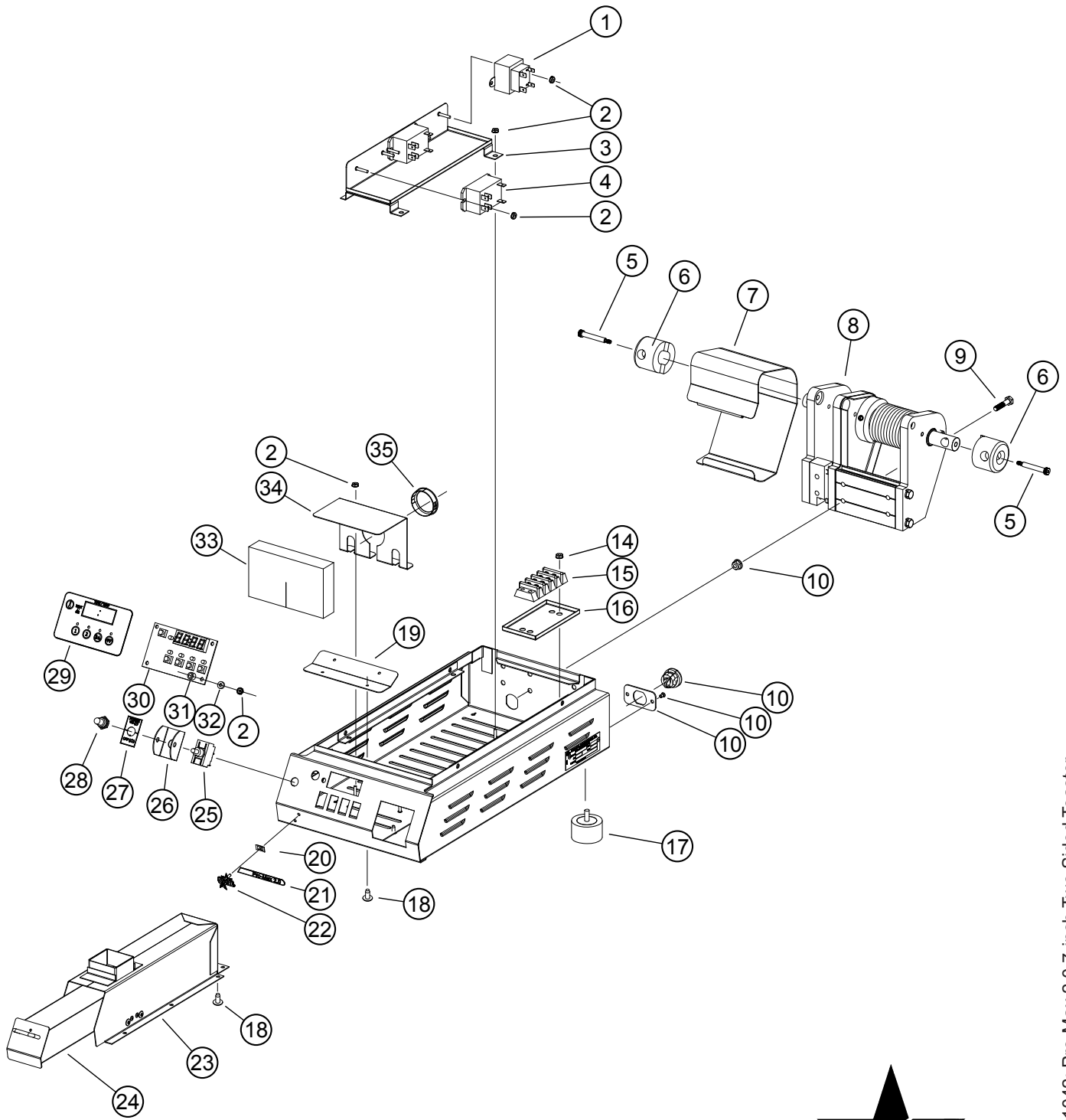

2M-Z21042: Pro-Max 2.0 7-inch Two Sided Toaster



Model: PST7E Base Assembly

SK2845

Rev. - 1/26/15

PARTS LIST

January 28, 2016

Model: PST7E Base				
Fig. No	Part Number	Qty	Description	Application
1	2E-05-07-0351	1	TRANSFORMER 115/10V 6VA	120V
	2E-05-07-0350		TRANSFORMER 230V/10V 6VA	230V, 240V, UK
2	2C-Z2594	19	NUT 6-32 HEX W STL NP	
3	D9-GR0680	1	WELD AY.,RELAY & TFMR MT.	
4	2E-Z22595	2	RELAY DBL POLE-SNGL THROW	*AFTER 08/07/2019
4	2E-Z3335	2	RELAY DBL POLE-SNGL THROW	
5	2C-Z18302	2	SCR,SHLDR,1/4 DIA.X1.5	
6	2A-Z18301	2	COLLAR AND STOP	
7	D9-Z19543	1	SPRING COVER, 7"	
8	D9-GR0704	1	ASSY.,HINGE,7,Z18289 SPRG	
9	2C-41180	12	BOLT HEX 1/4-20X1 1/4	
10	2C-20301-20	6	NUT LOCK STOVER 1/4-20	
11	2K-Y2968	1	BUSHING - HEYCO 7W-2	120V, 240V
12	2C-Y6138	6	RIVET 1/8X.250 POP SS SM	
13	D9-Z19225	1	CORD PLATE	120V, 240V
14	2C-Z3447	1	NUT 8-32 HEX W/EXTERNAL	
15	2E-Z2894	1	TERMINAL BLOCK (304)	
16	D9-Z19226	1	PAN,TERMINAL BLOCK	
17	2R-Z18201	4	FOOT 1.69X1 SIL 1/4 20	
18	2C-6349	10	SCREW #8X3/8 B THP STL NP	
19	D9-Z19505	1	ANGLE,CTRL,7	
20	2C-8477	2	CLIP .125 PO STL PHOS	
21	2M-Z18452	1	LABEL, PRO-MAX	
22	2M-Z15305	1	STAR LOGO, SMALL	
23	D9-GR0696	1	WLD & RIVET AY.,7 GRS HSG	
24	D9-GR0690	1	GREASE CUP AY.,7	
25	2E-Z3808	1	SWITCH(EATON)-30A@120V,	
26	Z1-70-07-0343	1	SWITCH GUARD	
27	2M-Z18461	1	LABEL, POWER, ON AND OFF	
28	2I-05-07-0013	1	BOOT SWITCH	
29	2M-Z19409	1	OVERLAY,Z11593 EL CONTROL	
30	2J-Z11593	1	CONTROL BOARD, SINGLE SG	PGT7ESW
	2J-Z17371			
31	2K-Z1971	4	SPACER .257X.75X.25 NYLON	
32	2K-08-07-0004	4	SPACER ROUND NYLON	
33	D9-Z19533	1	INSULATION,ELEC. CTRL.,7"	
34	D9-Z19242	1	HEAT SHIELD,CTRL,7	
35	2K-Z19330	1	BUSHING HEYCO #2883	
NI	2E-Z2935	1	CORD SJTO 14/3 NEMA 5-15P	120V
NI	2E-Y9251	1	CORD SET CONT EUR 16AMP	230V
NI	2E-Z9192	1	CORDSET(DETACHABLE) - UK	UK
NI	2E-Y9253	1	INLET IEC 320 16 AMP	230V, UK
NI	2M-Z19532	1	OVERLAY,BEZEL,GRS. CUP,7	

2M-Z21042: Pro-Max 2.0 7-inch Two Sided Toaster

PGT7ESW Unique Parts

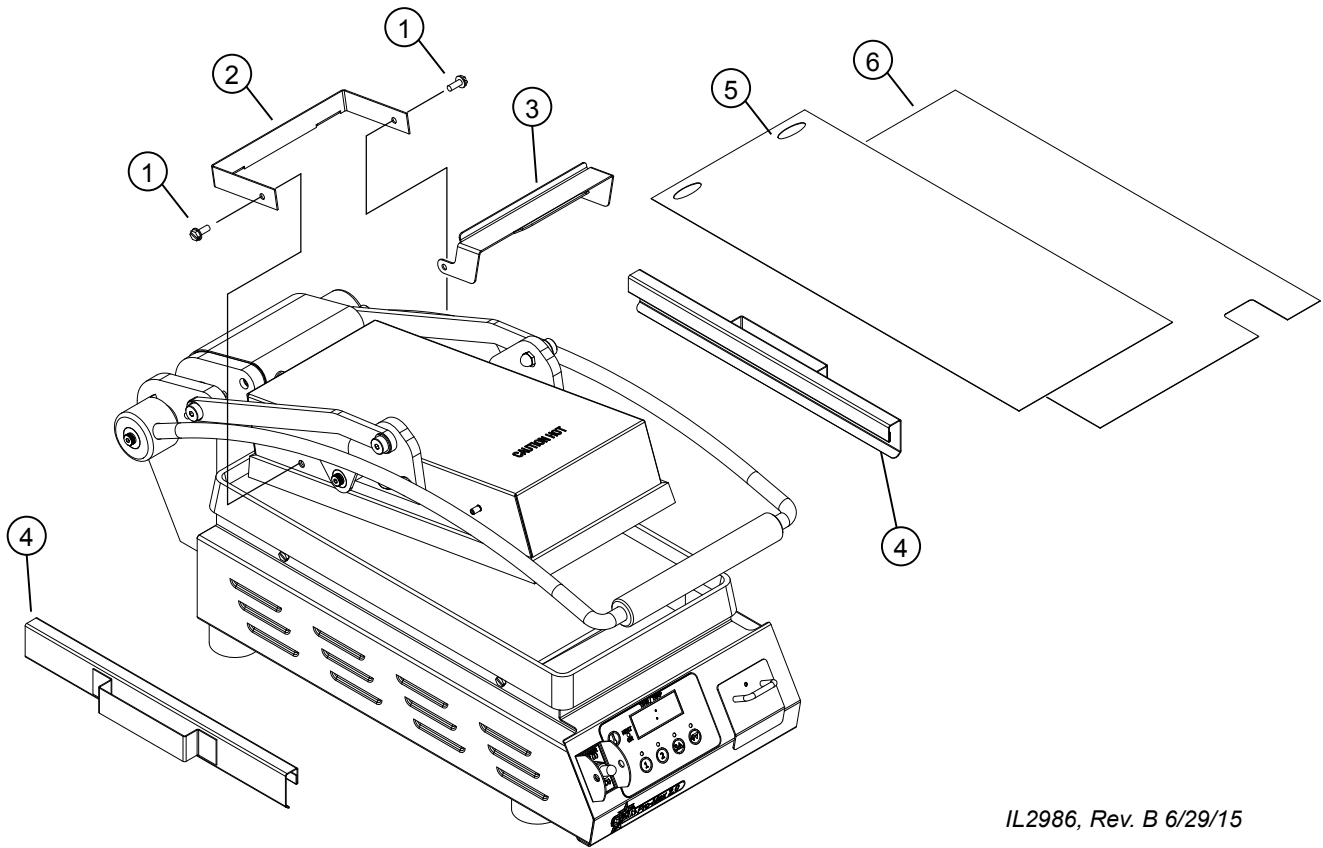

IL2986, Rev. B 6/29/15

D9-GR0720; 7" SG NON-STICK SHEET KIT			
Fig No	Part No	Qty	Description
1	2C-Z5883	not included	SCREW, 10-24 X 1/2 SELF-DRILLING
2	D9-Z20145	not included	REAR BRACKET
3	D9-Z20580	not included	PTFE BRACKET, FRONT CLIP
4	D9-GR0722	not included	LOWER BRACKET ASSY
5	2H-Z20036	6	UPPER NON-STICK SHEET
6	2H-Z20035	6	LOWER NON-STICK SHEET

STAR MANUFACTURING GROUP

Star - Holman - Lang - Wells - Toastmaster
 265 Hobson St., Smithville, TN 37166 U.S.A.
 (800) 264-7827 (314) 781-2777
www.star-mfg.com