

WELLS MANUFACTURING

265 Hobson Street, Smithville, Tennessee 37166

telephone: 314-678-6314

fax: 314-781-2714

www.wells-mfg.com

OWNERS MANUAL
for
**COUNTER TOP
ELECTRIC
HOTPLATES**

Models:
H33
H63
H65
H70
H115

Model H70

Includes
**INSTALLATION
USE & CARE
EXPLODED VIEW
PARTS LIST
WIRING DIAGRAM**

IMPORTANT: DO NOT DISCARD THIS MANUAL

This manual is considered to be part of the appliance and is to be given to the OWNER or MANAGER of the restaurant, or to the person responsible for TRAINING OPERATORS of this appliance. Additional manuals are available from your WELLS DEALER.

THIS MANUAL MUST BE READ AND UNDERSTOOD BY ALL PERSONS USING OR INSTALLING THIS APPLIANCE. Contact your WELLS DEALER if you have any questions concerning installation, operation or maintenance of this equipment.

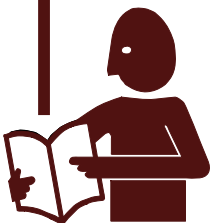

LIMITED EQUIPMENT WARRANTY

Wells Manufacturing warranties new products to be free from defects in material and/or workmanship for a period of one [1] year from the date of original installation, except as noted below. Defects that occur as a result of normal use, within the time period and limitations defined in this warranty, will at Wells' discretion have the parts replaced or repaired by Wells or a Wells-authorized service agency.

THIS WARRANTY IS SUBJECT TO ALL LISTED CONDITIONS.

Repairs performed under this warranty are to be performed by a Wells-authorized service agency. Wells will not be responsible for charges incurred or service performed by non-authorized repair agencies.

In all cases, the nearest Wells-authorized service agency must be used.

Wells will be responsible for normal labor charges incurred in the repair or replacement of a warrantied product within 50 miles (80.5 km) of an authorized service agency. Time and expense charges for anything beyond that distance will be the responsibility of the owner. All labor will need to be performed during regular service hours. Any overtime premium will be charged to the owner. For all shipments outside the U.S.A. and Canada, please see the International Warranty for specific details.

It is the responsibility of the owner to inspect and report any shipping damage claims, hidden or otherwise, promptly following delivery.

No mileage or travel charges will be honored on any equipment that is deemed portable. In general, equipment with a cord and plug weighing less than 50 lb. (22.7 kg) is considered portable and should be taken or shipped to the closest authorized service agency, transportation prepaid.

CONTACT

Should you require any assistance regarding the operation or maintenance of any Wells equipment; write, phone, fax or email our service department. In all correspondence mention the model number and the serial number of your unit, as well as the voltage or type of gas you are using.

Business hours are 8:00 a.m. to 4:30 p.m. Central Standard Time

Telephone 800.264.7827

Fax 314.781.2714

Email customerservice@star-mfg.com

www.wells-mfg.com

WARRANTY EXCLUSIONS

THE FOLLOWING WILL NOT BE COVERED UNDER WARRANTY.

- Any product which has not been installed, cleaned, maintained, or used in accordance with the directions published in the appropriate installation sheet and/or owner's manual as well as national and local codes, including incorrect gas or electrical connection. Wells is not liable for any unit which has been mishandled, abused, misapplied, subjected to chlorides, harsh chemicals, or caustic cleaners, damaged from exposure to hard water, modified by unauthorized personnel, damaged by flood, fire, or other acts of nature [or God], or which have an altered or missing serial number.
- Installation, labor, and job checkouts, calibration of heat controls, air and gas burner/bypass/pilot adjustments, gas or electrical system checks, voltage and phase conversions, cleaning of equipment, or seasoning of griddle surface.
- Replacement of fuses or resetting of circuit breakers, safety controls, or reset buttons.
- Replacement of broken or damaged glass components, quartz heating elements, and light bulbs.
- Labor charges for all removable parts in gas charbroilers and hotplates, including but not limited to burners, grates, and radiants.
- Any labor charges incurred by delays, waiting time, or operating restrictions that hinder a service technician's ability to perform service.
- Parts that fail or are damaged due to normal wear or labor for replacement of Items that can easily be replaced during a daily cleaning routine. such as but not limited to silicone belts, PTFE non-stick sheets, knobs, control labels, bulbs, fuses, quartz heating elements, baskets, racks, and grease drawers.
- Components that should be replaced when damaged or worn, but have been field-repaired instead [eg. field-welded fry pots].
- Any loss of business or profits.

ADDITIONAL WARRANTIES

Specialty/chain specific versions may also have additional and/or extended warranties.

PRODUCTS	PARTS	LABOR
universal ventless hoods	2 years	1 year
canopy hoods	2 years	1 year
"Cook'n Hold" equipment [HW10, HWSMP, LLSC7, LLSC7WA, LLSC11, and LLSC11WA]	2 years	1 year
cast iron grates, burners, and burner shields	1 year	
original Wells parts sold to repair Wells equipment	90 days	
Service First	1 year	

TABLE OF CONTENTS

WARRANTY	
SPECIFICATIONS	1
FEATURES & OPERATING CONTROLS	2
PRECAUTIONS & GENERAL INFORMATIOS	3
AGENCY APPROVAL INFORMATION	3
INSTALLATION	4
OPERATION	5
CLEANING INSTRUCTIONS	6
TROUBLESHOOTING	7
EXPLODED VIEW & PARTS LIST	8 - 17
WIRING DIAGRAMS	18 - 19
PARTS & SERVICE	21
CUSTOMER SERVICE DATA	

INTRODUCTION

Thank You for purchasing this Wells Manufacturing appliance.

Proper installation, professional operation and consistent maintenance of this equipment will ensure that it gives you the very best performance and a long, economical service life.

This manual contains the information needed to properly install this equipment, and to use and care for the equipment in a manner which will ensure its optimum performance.

SPECIFICATIONS

MODEL	ELEMENT	WIDTH	DEPTH	VOLTS	AMPS	kW	PLUG	LEG HEIGHT
H33	Single 6" Coil	12-5/8"	12-5/8"	120 V 1ø	12.5 A	1.5 kW	NEMA 5-15P	4"
H63	Dual 8" Coils	14-3/4"	23-1/2"	208 V 1ø	18.8 A	3.9 kW	NEMA 6-30P	
				240 V 1ø	21.7 A	5.2 kW	NEMA 6-30P	
H65	Dual 8" Coils	13"	29-9/16"	208 V 1ø	18.8 A	3.9 kW	None	
				240 V 1ø	21.7 A	5.2 kW	None	
H70	Dual 9" french plates	14-3/4"	23-1/2"	208 V 1ø	14.4 A	3.0 kW	None	
				240 V 1ø	16.7 A	4.0 kW	None	
H115	Dual 6" Coils	14-3/4"	23-9/16"	120 V 1ø	13.8 A	1.7 kW	NEMA 5-15P	1"

FEATURES & OPERATING CONTROLS

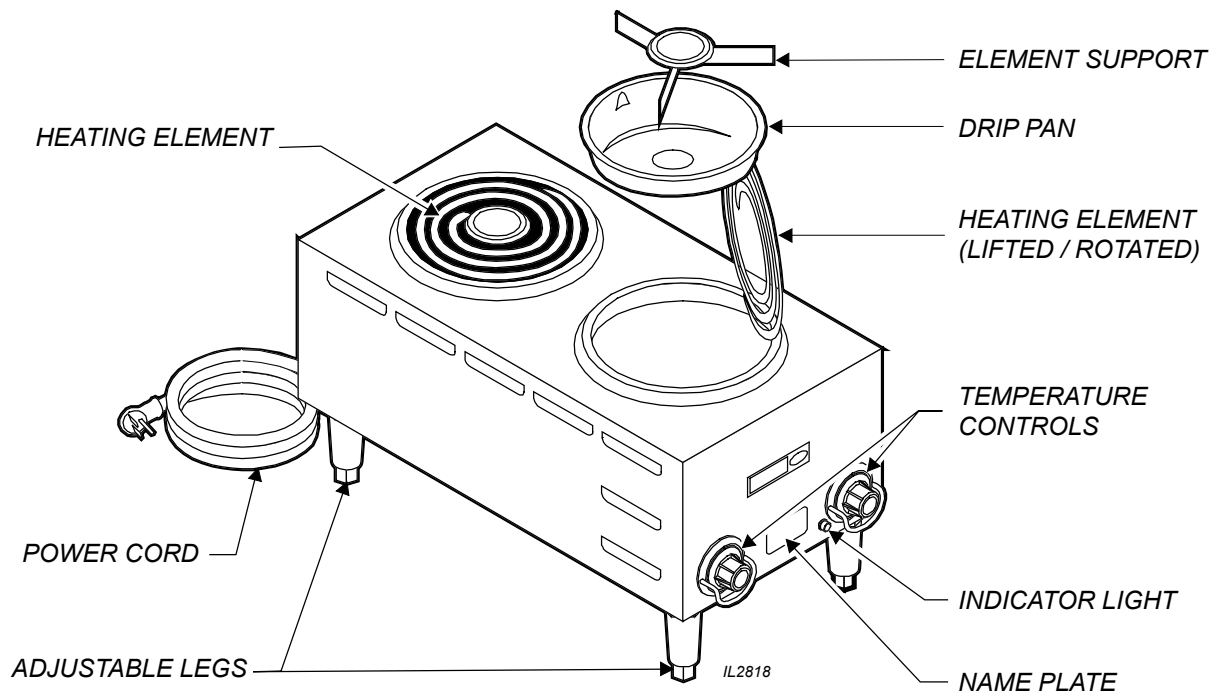

	Provides heat for food preparation
Heating Element	Coil-type elements rotate for access to drip pan <i>Note: Solid (french plate) elements on model H-70 do not lift</i>
Element Support*	Holds coil-type element in proper position
Drip Pan*	Collects drippings and holds element support Also deflects heat from element for more efficient cooking
Temperature Control	Infinite switch to control temperature of heating element
Indicator Light	Glows any time temperature control is on
Name Plate	Lists manufacturer, model number and serial number Also lists voltage and wattage rating
Power Cord (when provided)	Connects hotplate to electrical power Some units require wiring directly into electrical circuit
Adjustable Legs	Provide ventilation under hotplate Allow hotplate to be leveled

* not used on model H70

PRECAUTIONS AND GENERAL INFORMATION

This appliance is intended for use in commercial establishments only.

This appliance is intended to prepare food for human consumption. No other use is recommended or authorized by the manufacturer or its agents.

Operators of this appliance must be familiar with the appliance use, limitations and associated restrictions. Operating instructions must be read and understood by all persons using or installing this appliance.

Cleanliness of this appliance is essential to good sanitation. Read and follow all included cleaning instructions and schedules to ensure the safety of the food product.

Hotplates with coil-type heating elements must be operated with drip pan and element support properly installed.

Disconnect the hotplate from electrical power before performing any maintenance or servicing.

DO NOT submerge hotplate in water. DO NOT splash or pour water over, onto or into controls, control panel or wiring.

The technical content of this manual, including any wiring diagrams, schematics, parts breakdown illustrations and/or adjustment procedures, is intended for use by qualified technical personnel.

Any procedure which requires the use of tools must be performed by a qualified technician.

This manual is considered to be a permanent part of the appliance. This manual and all supplied instructions, diagrams, schematics, parts breakdown illustrations, notices and labels must remain with the appliance if it is sold or moved to another location.

This appliance is made in the USA. Unless otherwise noted, this appliance has American sizes on all hardware.



WARNING: ELECTRIC SHOCK HAZARD

All servicing requiring access to non-insulated electrical components must be performed by a factory authorized technician.

DO NOT open any access panel that requires the use of tools. Failure to follow this warning can result in severe electrical shock.



CAUTION: RISK OF DAMAGE

DO NOT connect and/or energize this appliance until all installation instructions are read and followed. Damage to the appliance will result if these instructions are not followed.

AGENCY APPROVAL INFORMATION

This appliance complies with NSF Standard 4 only when maintained and operated per the instructions in this manual.

This appliance is UL listed under E6070.



STD 4



E6070

INSTALLATION

NOTE: DO NOT discard the carton or other packing materials until you have inspected the appliance for hidden damage and tested it for proper operation. Refer to *SHIPPING DAMAGE CLAIM PROCEDURE* on the inside front cover of this manual.



CAUTION: ELECTRIC SHOCK HAZARD

The ground prong of the power cord is part of a system designed to protect you from electric shock in the event of internal damage to the appliance. NEVER CUT OFF THE GROUND PRONG (large round prong). NEVER TWIST A PRONG TO FIT AN EXISTING RECEPTACLE. Contact a licensed electrician to install an electrical receptacle appropriate to the voltage and amperage requirements of the hotplate.

IMPORTANT:

Damage due to being plugged into the wrong voltage or phase is NOT covered by Warranty.

UNPACKING & INSPECTION

Carefully remove the hotplate from the carton. Remove all protective plastic film, packing materials and accessories from the hotplate before plugging the hotplate into electrical power or otherwise performing any installation procedure.

Carefully read all instructions in this manual and the Installation Instruction Sheet packed with the hotplate before starting any installation.

Read and understand all labels and diagrams attached to the hotplate.

Carefully account for all components and accessories before discarding packing materials. Store all accessories in a convenient place for later use.

SETUP

Supplied legs must be properly installed.

Setup the hotplate only on a firm level surface. Non-combustible material (e.g. metal, terrazzo) is recommended.

Maintain at least 1" from adjacent surfaces.

ELECTRICAL

Refer to the nameplate. Verify the electrical service power. Voltage and phase must match the nameplate specifications. Connecting the hotplate to the wrong voltage can severely damage the equipment or cause noticeably decreased performance.

If your hotplate is equipped with a grounded electric power cord, this cord must be plugged into a properly grounded electrical receptacle.

If your hotplate is not supplied with a cordset, the hotplate must be installed by a licensed electrician in accordance with all applicable codes and ordinances.

GENERAL OPERATIONAL NOTES

Carefully read the description of the hotplate operation on the specification sheet.

DO NOT attempt to perform any maintenance or service unless the hotplate is disconnected from electrical power.

DO turn the circuit breaker for the hotplate off before cleaning, servicing or performing any maintenance.

DO NOT use sharp objects or metal implements to clean the heating elements.

DO use a plastic spatula or plastic scouring pad to remove burned-on food product.

OPERATION

Each heating element is controlled by an infinite switch temperature control:

OFF removes power from the element

LOW thru 8 are temperature settings

Higher numbers indicate higher temperatures

There is a continuous range of settings between LOW and HI

HI is a continuous ON setting

The indicator light will glow any time the temperature control is on.

Cooking Recommendations:

Save energy by turning the temperature control off any time the hotplate is not in use. The coil-type heating elements will provide full heat within 30 seconds, while french plate heating elements will reach full heat within 2 minutes, making it unnecessary to leave the unit on during intermittent use.

Each heating element can hold up to a 16 quart pot or pan. For efficient heating of food product, pots and pans should be no more than 10" in diameter.

Maximize the efficiency of solid (french plate) elements by using flat-bottom pots and pans.

Stir thick liquids frequently to maintain a consistent temperature.



CAUTION: HOT SURFACE

Exposed surfaces can be hot to the touch and may cause burns.

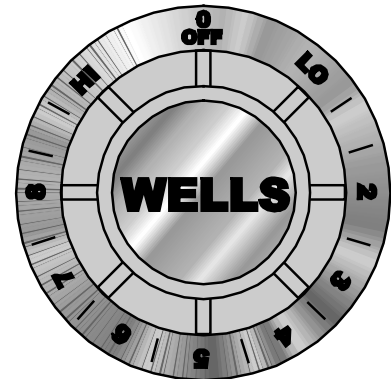

Temperature Control Knob

IMPORTANT:

The dial markings are an INDICATION of temperature only. The temperature of the food product depends on many factors, including the size, shape and material of the food container, and the quantity and consistency of the food product.

CLEANING INSTRUCTIONS



CAUTION: ELECTRIC SHOCK HAZARD

Disconnect hotplate from electric power before cleaning.



CAUTION: BURN HAZARD

Allow hotplate element and cabinet to cool completely before cleaning.



CAUTION: ELECTRIC SHOCK HAZARD

Do not submerge hotplate in water.

IMPORTANT: DO NOT spill or pour water into interior of hotplate.

IMPORTANT: DO NOT spill or pour water into controls, control panel or wiring.

DO NOT submerge hotplate in water. Damage to internal components will occur.

Damage to internal components from water damage is NOT covered by warranty.

DO NOT use metal implements, steel wool or metal scouring pads to clean heating elements.

PREPARATION

Unplug or disconnect hotplate from electrical power before cleaning. Allow hotplate to cool completely before cleaning.

FREQUENCY

Daily

TOOLS

Plastic Spatula and Plastic Scouring Pad

Clean Cloth or Sponge

Mild Detergent or Cleaner Formulated for Stainless Steel

Warm Water

CLEANING

Unplug or disconnect hotplate from electrical power and allow heating element to cool completely before cleaning.

COILED HEATING ELEMENTS:

Lift coiled heating elements and remove drip pans. Clean drip pans with a plastic spatula or plastic scouring pad, mild detergent and warm water. DO NOT use metal implements, steel wool or metal scouring pads to clean drip pans. Rinse drip pans by wiping with a clean cloth or sponge dampened with clean water.

Clean heating elements with a plastic spatula or plastic scouring pad, mild detergent and warm water. DO NOT use metal implements, steel wool or metal scouring pads to clean elements. Rinse by wiping with a clean cloth or sponge dampened with clean water.

Reinstall drip pans and gently lower heating element.

FRENCH PLATE HEATING ELEMENTS:

French plate elements do not lift. Clean heating elements with a plastic spatula or plastic scouring pad, mild detergent and warm water. DO NOT use metal implements, steel wool or metal scouring pads to clean elements. Rinse by wiping with a clean cloth or sponge dampened with clean water.

CABINET:

Wipe the outer portions of the hotplate cabinet with a clean soft cloth or sponge dampened with warm water and a mild detergent or cleaner formulated for cleaning stainless steel. DO NOT use steel wool to clean hotplate cabinet.

Rinse by wiping hotplate cabinet with a clean soft cloth or sponge moistened with clean warm water.

Dry cabinet and elements by wiping with a clean soft dry cloth.

TROUBLESHOOTING

SYMPTOM	POSSIBLE CAUSE	SUGGESTED REMEDY
Hotplate won't heat	Not plugged in, damaged plug or cord or circuit breaker tripped	Check plug and cord
		Check / reset circuit breaker
One or more sections won't heat	Temperature control not on	Turn temperature control to desired setting
	Damaged temperature control, element or other internal component	Contact Authorized Wells Service Agency for repairs
Hotplate not hot enough	Temperature control not set	Adjust for desired temperature
	Operating 208/240V unit at 120V	Be sure supply voltage matches nameplate voltage
	Damaged temperature control, element or other internal component	Contact Authorized Wells Service Agency for repairs

NOTE: There are no user serviceable components in this appliance. In all cases of damage or component malfunction, contact your Authorized Wells Service Agency for repairs.

EXPLODED VIEW: H33

H-33 COUNTERTOP ELECTRIC HOTPLATE - 115V - SPIRAL ELEMENT

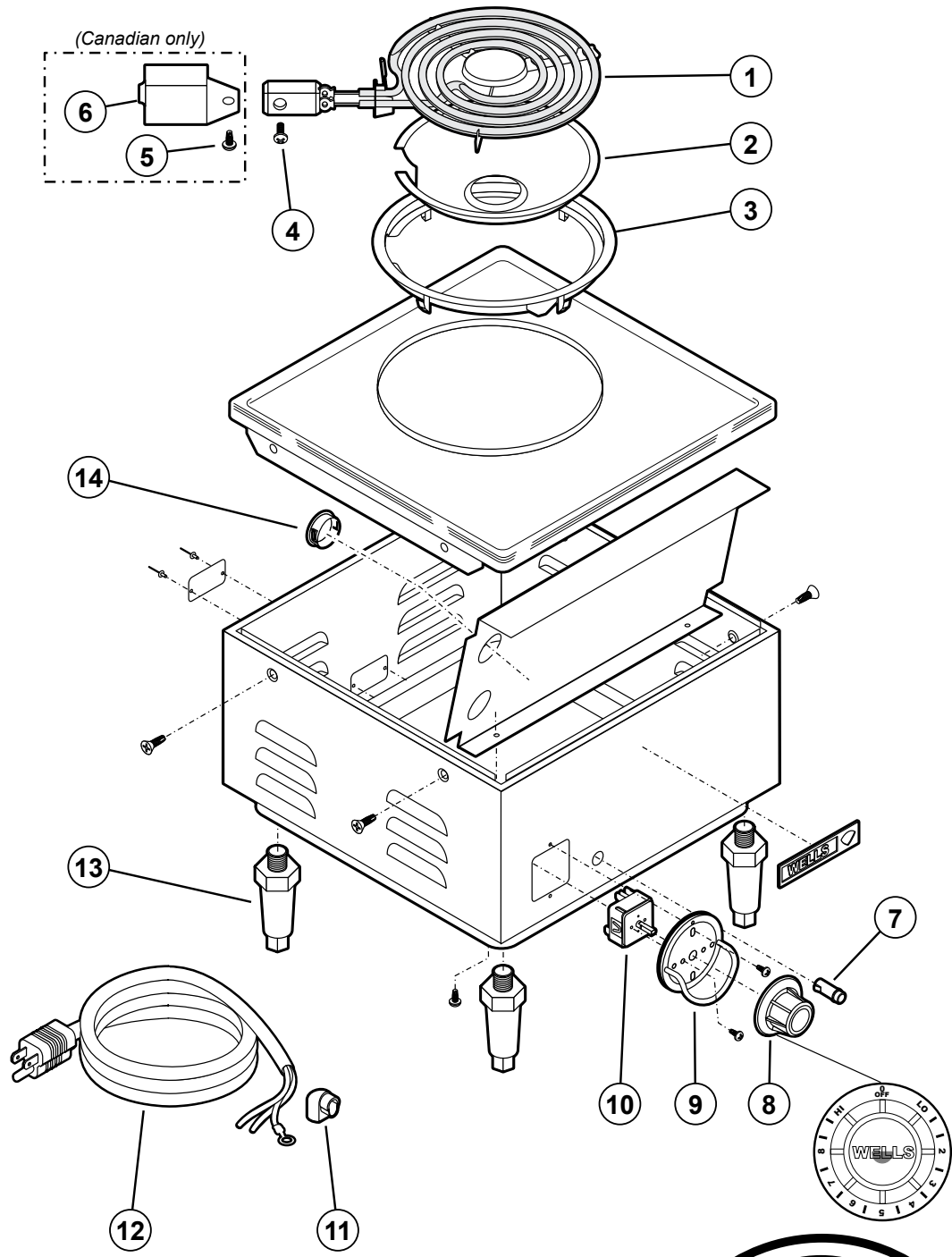

Model: H33
Countertop Electric Hotplate - 115V - Spiral Element
PL221

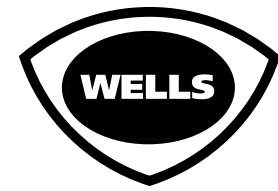

IL1747 Rev. A 4/24/09

221 p/n 2M-303733 Owners Manual CT Hotplate

H33 COUNTERTOP ELECTRIC HOTPLATE			
Fig No	Part No	Qty	Description
1	2N-30514ELUL	1	ELEMENT 120V 1500WW H33
2	2D-30514DT	1	DRIP TRAY H115 & H33
3	I7-30514CR	1	ASSY CLIPS & RING H115 & H33
4	2C-33977	AR	SCREW 8-32X3/8 PH BND HD
5	2C-300243	AR	SCREW 10-32X1/4 PH BND HD
6	I7-43370	1	COVER TERM H33 115 CSA
7	2J-30516	1	LIGHT SIGNAL AMBER
8	2R-30371	1	KNOB ASSY WARMERS
9	D8-30256	1	TRIM RING ASSY
10	2E-30570	1	SWITCH INFINITE 120V
11	2K-31217	1	STRAIN RELIEF 90DEG
12	2E-35539	1	CORD SET 120V 15A 16GA 4FT
13	2R-Z0314	4	FOOT, DIE CAST, METAL 3/8-16
14	2K-31040	1	BUSHING 7/8 OD

EXPLODED VIEW: H63

H-63 COUNTERTOP ELECTRIC HOTPLATE - 208/240V - SPIRAL ELEMENT

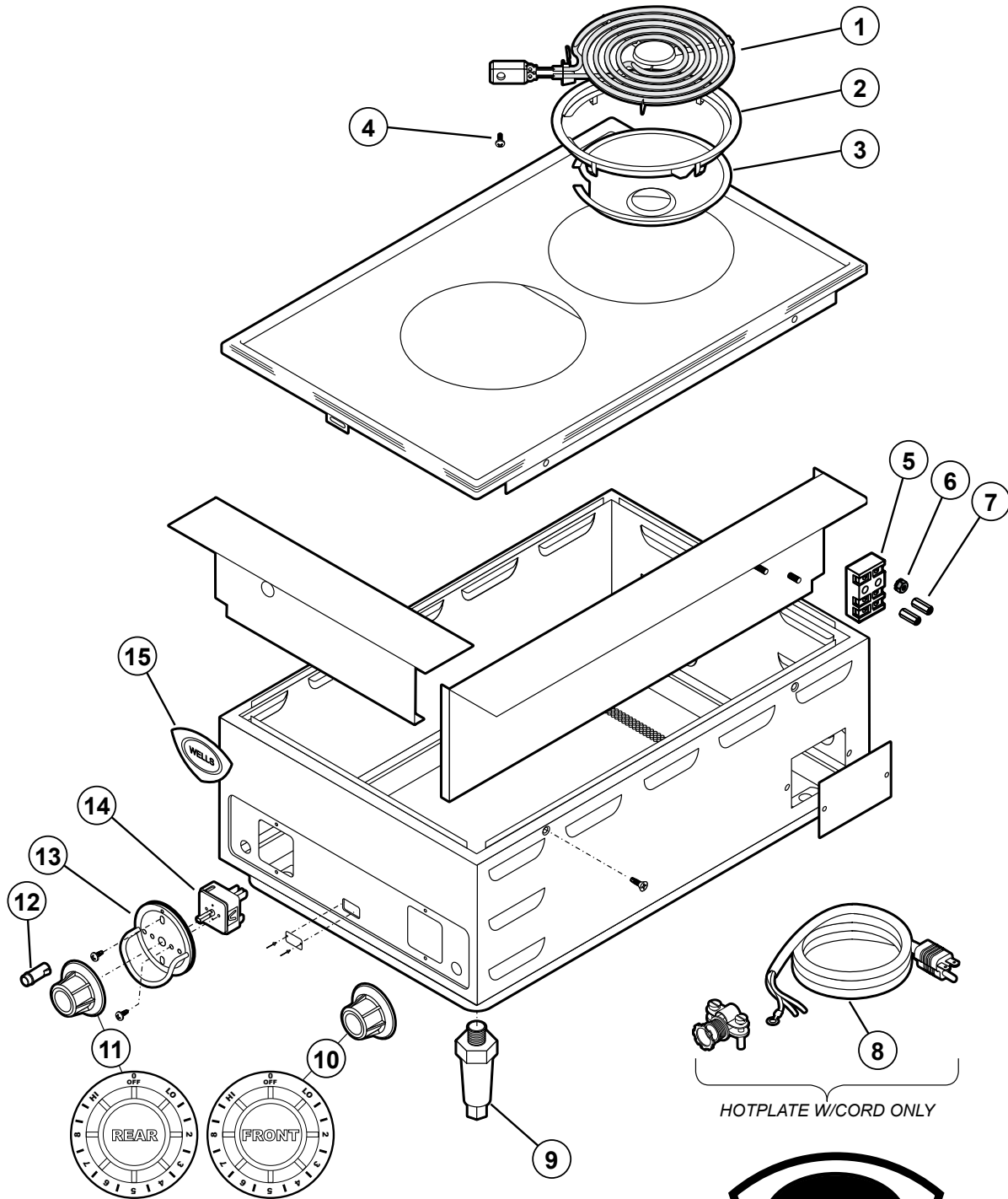

Model: H63
 Countertop Electric Hotplate - 208/240V - Spiral Element
 PL221

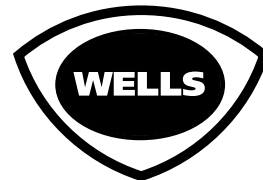

IL1748 Rev. B 1/18/10

221 p/n 2M-303733 Owners Manual CT Hotplate

H63 COUNTERTOP ELECTRIC HOTPLATE			
Fig No	Part No	Qty	Description
1	2N-30293ELUL	2	ELEMENT 240V 260W H63
2	I7-30293CR	2	ASSY CLIPS & TRIM RING H-
3	2D-30293DT	2	DRIP TRAY H-63
4	2C-33977	2	SCREW 8-32X3/8 PH BND HD
5	WS-50131	1	TERM BLOCK KIT (RETRO 301)
6	2C-35736	2	NUT 8-32 HEX KEPS MS GREEN
7	2C-41974	2	NUT 8-32 HEX 7/8 LONG ALU
8	2E-35259	1	CORD SET 250V 30A 12G 6-30P
9	2A-Z0314	4	FOOT, DIE CAST, METAL 3/8-16
10	2R-30583	1	KNOB ASSY FRONT HOTPLATE
11	2R-30584	1	KNOB RR HP91
12	2J-30516	2	LIGHT SIGNAL AMBER
13	D8-30256	2	TRIM RING ASSY
14	2E-30562	2	SWITCH INFINITE 240V
15	2M-300534	1	TRADEMARK DOMED LABEL WARMER

EXPLODED VIEW: H65

H-65 COUNTERTOP ELECTRIC HOTPLATE - 208/240V - SPIRAL ELEMENT

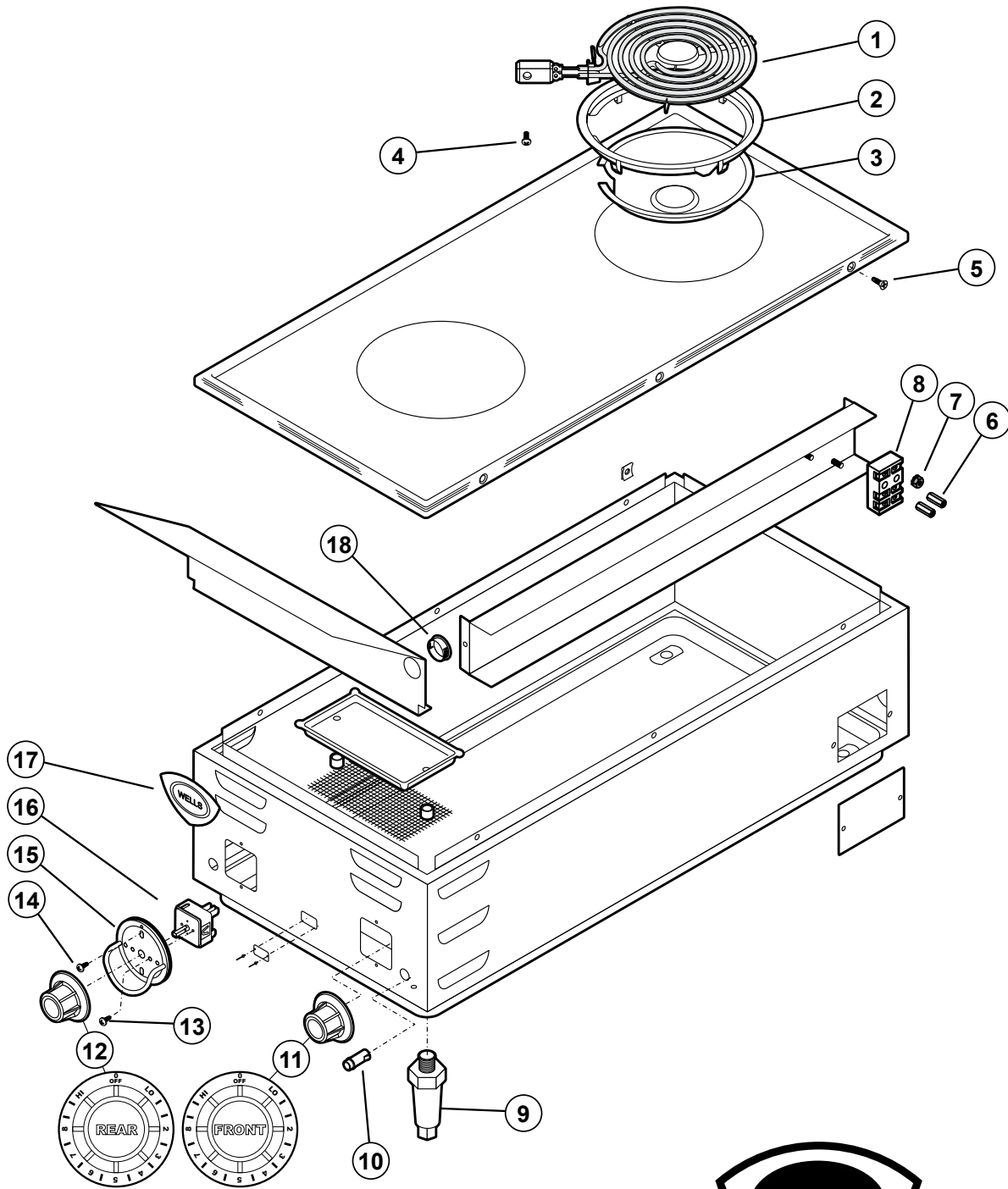

Model: H65
 Countertop Electric Hotplate - 208/240V - Spiral Element
 PL221



IL1749 Rev. A 4/24/09

221 p/n 2M-303733 Owners Manual CT Hotplate

H65 COUNTERTOP ELECTRIC HOTPLATE 208/240V			
Fig No	Part No	Qty	Description
1	2N-30293ELUL	2	ELEMENT 240V 2600W
2	I7-30293CR	2	ASSY CLIPS & TRIM RING
3	2D-30293DT	2	DRIP TRAY
4	2C-33977	2	SCREW 8-32X3/8 PH BND HD
5	2C-54285	AR	SCREW 8-32X3/8 PH 100 FL
6	2C-41974	2	NUT 8-32 HEX 7/8 LONG ALU
7	2C-35736	AR	NUT 8-32 HEX KEPS MS GREEN
8	WS-50131	1	TERM BLK KIT - 3POLE 85AMP
9	2A-Z0314	4	FOOT, DIE CAST, METAL 3/8-16
10	2J-30516	2	LIGHT SIGNAL AMBER
11	2R-30583	1	KNOB ASSY FRONT HOTPLATE
12	2R-30584	1	KNOB ASSY REAR HOTPLATE
13	2C-31697	AR	SCREW 8-32X3/16 PH RD HD
14	2C-33935	AR	SCREW 6ABX5/16 PH PAN SMS
15	D8-30256	2	TRIM RING ASSY
16	2E-30562	2	SWITCH INFINITE 240V
17	2M-300534	1	TRADEMARK DOMED LABEL
18	2K-31040	1	BUSHING 7/8 OD

EXPLODED VIEW: H70

H-70 COUNTERTOP ELECTRIC HOTPLATE - 208/240V - SOLID (FRENCH PLATE) ELEMENT

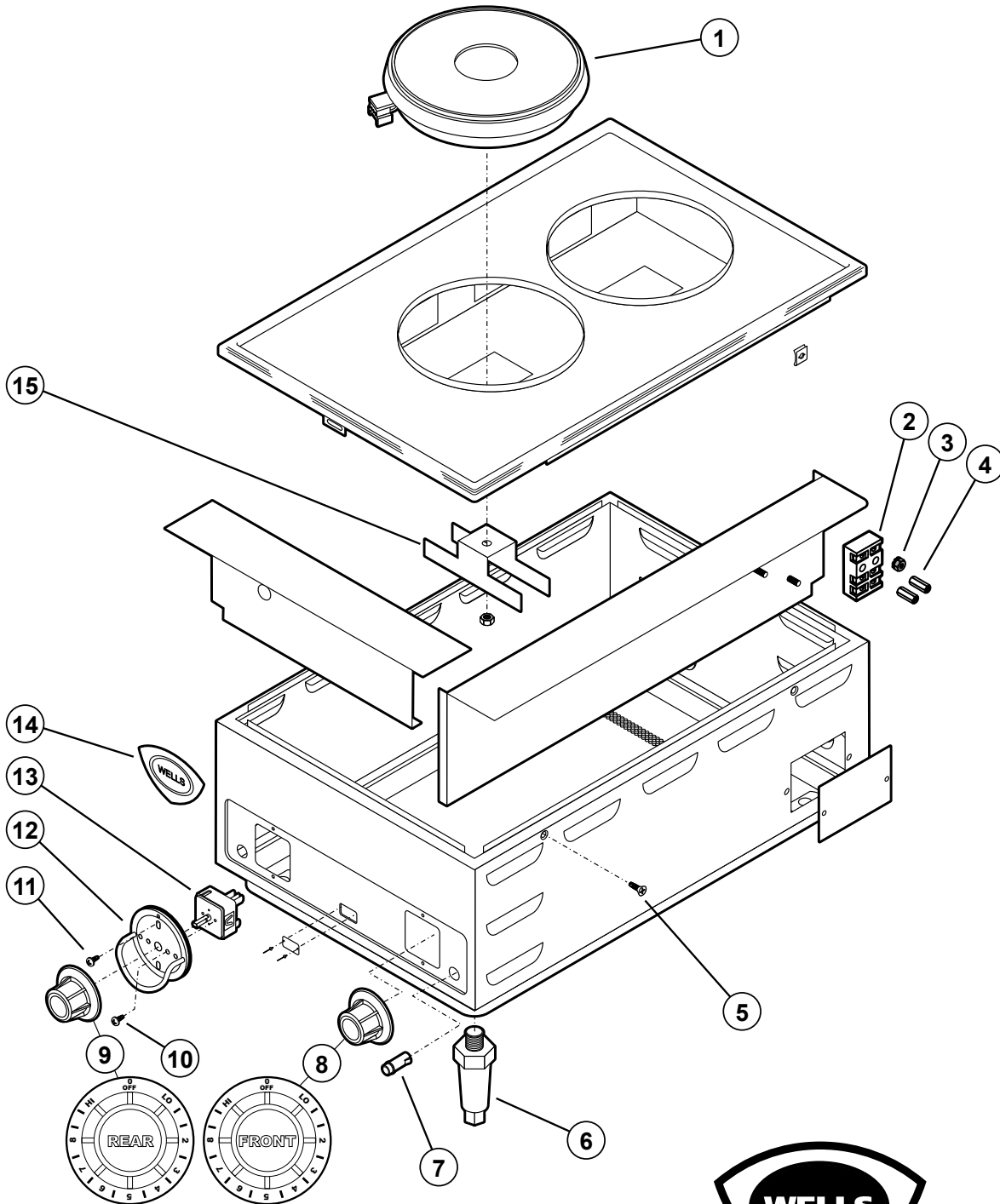

Model: H70
Countertop Electric Hotplate - 208/240V - French Plate

PL221



IL1750 Rev. B 8/20/09

221 p/n 2M-303733 Owners Manual CT Hotplate

H70 COUNTERTOP ELECTRIC HOTPLATE 208/240V			
Fig No	Part No	Qty	Description
1	WS-503973	2	ELEM HOTPLATE UPGRADE FUSED
2	2C-41974	2	NUT 8-32 HEX 7/8 LONG ALU
3	2C-35736	2	NUT 8-32 HEX KEPS MS GREEN
4	WS-50131	1	TERM BLOCK KIT (RETRO 301)
5	2C-34285	4	SCREW 8-32X3/8 PH
6	2R-Y5092	4	FEET ADJ 4GRAY 3/8-16
7	2J-30516	2	LIGHT SIGNAL AMBER
8	2R-30583	1	KNOB ASSY FRONT HOTPLATE
9	2R-30584	1	KNOB ASSY REAR HOTPLATE
10	2C-31697	AR	SCREW 8-32X3/16 PH RD HD
11	2C-33935	AR	SCREW 6ABX5/16 PH PAN SMS
12	D8-30256	2	TRIM RING ASSY
13	2E-30562	2	SWITCH INFINITE 240V
14	2M-300534	1	TRADEMARK DOMED LABEL
15	I7-35031	2	CLAMP ELEM H70

EXPLODED VIEW: H115

H-115 COUNTERTOP ELECTRIC HOTPLATE - 120V - SPIRAL ELEMENT

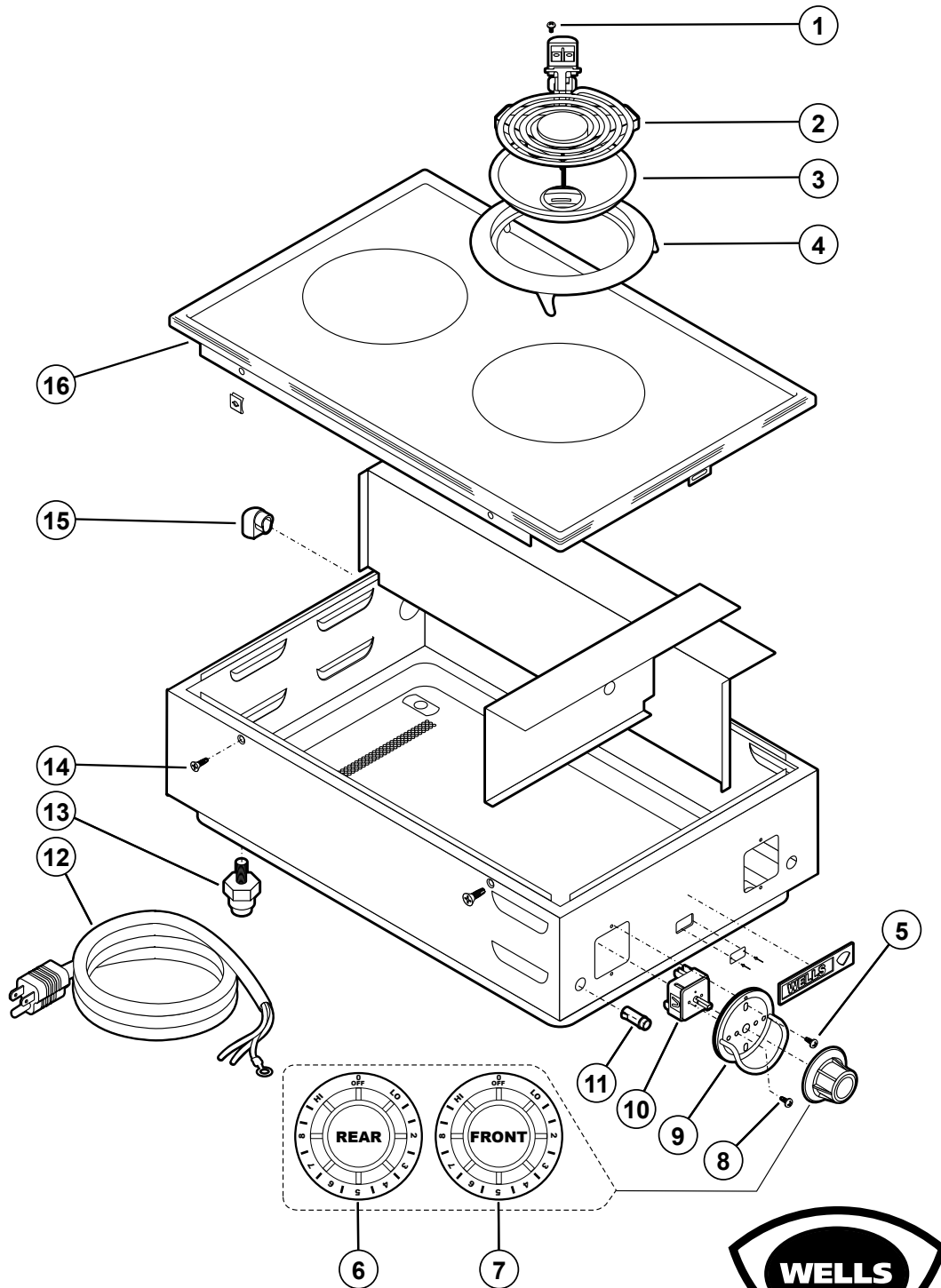

Model: H115
Countertop Electric Hotplate - 120V - Spiral Element
 PL221



IL1751 Rev. B 7/15/13

221 p/n 2M-303733 Owners Manual CT Hotplate

H115 COUNTERTOP ELECTRIC HOTPLATE 120V

Fig No	Part No	Qty	Description
1	2C-33977	2	SCREW 8-32X3/8 PH BND HD
2	2N-33573ELUL	2	ELEMENT 120V 825W H115
3	2D-30514DT	2	DRIP TRAY
4	I7-30514CR	2	ASSY CLIPS & RING
5	2C-33935	AR	SCREW 6ABX5/16 PH PAN SMS
6	2R-30584	1	KNOB RR HP91
7	2R-30583	1	KNOB ASSY FRONT HOTPLATE
8	2C-31697	AR	SCREW 8-32X3/16 PH RD HD
9	D8-30256	2	TRIM RING ASSY
10	2E-30570	2	SWITCH INFINITE 120V
11	2J-30516	2	LIGHT SIGNAL AMBER
12	2E-35539	1	CORD SET 120V 15A 16GA
13	2A-41946	4	LEG ADJUST 1 INCH
14	2C-34285	4	SCREW 8-32X3/8 PH 100 FL
15	2K-31217	1	STRAIN RELIEF 90DEG
16	I7-31103	1	TOP ASSY H115

WIRING DIAGRAM

WIRING DIAGRAM FOR ELECTRIC COUNTER TOP HOTPLATES H-63, H-65, H-70 and H-115

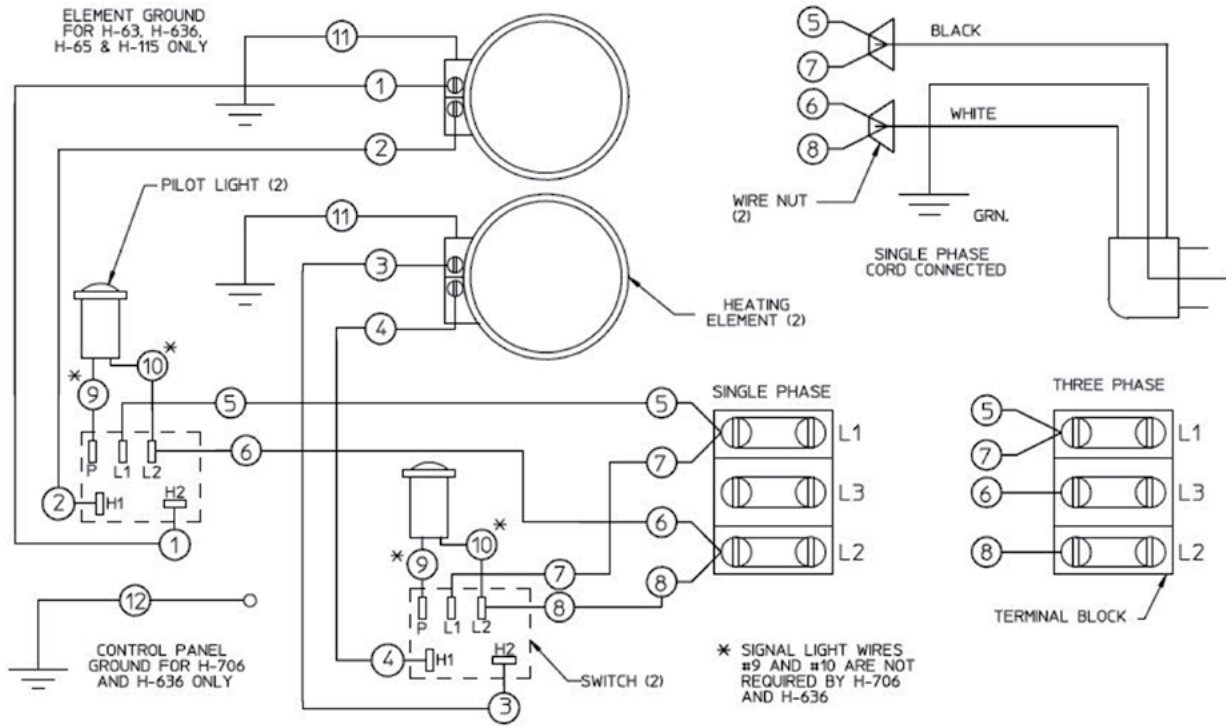

MODELS	VOLTS	AMPS 3 PHASE			AMPS 1 PHASE	FREQ.
		L1	L2	L3		
H-70 AND H-706	208	12.5	7.2	7.2	14.4	50 / 60 HZ
	240	14.4	8.3	8.3	16.7	
H-63, H-65 AND H-636		16.3	9.4	9.4	18.8	
		18.8	10.8	10.8	21.7	
H-115	120	-	-	-	13.8	

REV. A P/N 300093

WIRING DIAGRAM

WIRING DIAGRAM FOR H-33 120V SINGLE PHASE SER. NO. HS-1000 & UP

VOLTS	AMPS
120	12.5

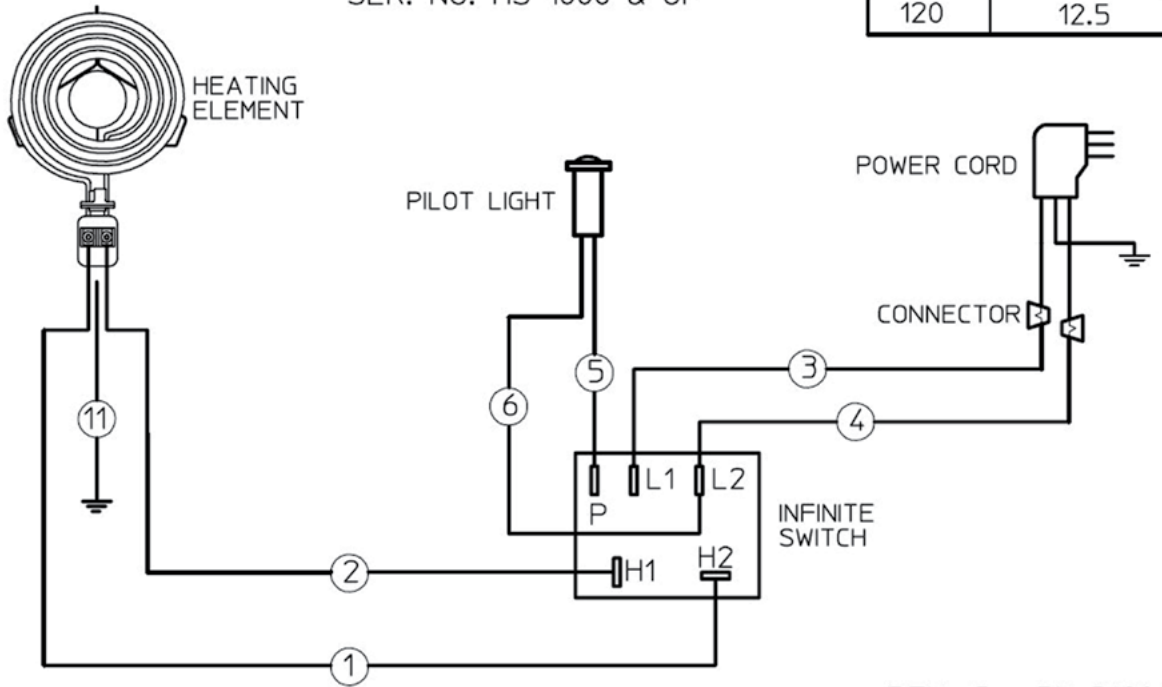

REV. G PN 31286

NOTES

PARTS & SERVICE

DESCRIPTION	SERVICE PART NO.	IMPORTANT: Use only factory authorized service parts and replacement filters.
4" LEGS, Plastic, Set of 4	2R-Y5092	
4" Legs, Die Cast Set of 4	WS-20563	For factory authorized service, or to order factory authorized replacement parts, contact your Wells authorized service agency, or call:
Drip Tray, 8" for H-63, H-65	17-30292	

Wells Manufacturing

265 Hobson Street
Smithville, Tennessee 37166 U.S.A.

Service Dept.
phone: (800) 264-7827
fax: (314) 781-2714

Service Parts Department
can supply you with the name
and telephone number of
the WELLS AUTHORIZED
SERVICE AGENCY
nearest you.

CUSTOMER SERVICE DATA

please have this information available if calling for service

RESTAURANT _____ LOCATION _____
INSTALLATION DATE _____ TECHNICIAN _____
SERVICE COMPANY _____
ADDRESS _____ STATE _____ ZIP _____
TELEPHONE NUMBER (____) _____ - _____
EQUIPMENT MODEL NO. _____
EQUIPMENT SERIAL NO. _____
VOLTAGE: (check one) 120V 208V 240V



Wells Bloomfield proudly supports CFESA
Commercial Food Equipment Service Association

SERVICE TRAINING - QUALITY SERVICE



CUSTOMER SATISFACTION



WELLS MANUFACTURING

265 Hobson Street, Smithville, Tennessee

37166 telephone: 800-264-7827

fax: 314-781-2714

www.wells-mfg.com