



**SOLUTIONS**

**WELLS BLOOMFIELD, LLC**  
265 Hobson St. • Smithville, TN 37166  
telephone: (800) 264-7827  
*wells-mfg.com*

**011D**



SS10ULT

**OWNERS MANUAL**

**BUILT-IN ROUND WELL  
WARMERS  
(Insulated & Non-Insulated)  
with  
THERMOSTAT  
CONTROL**

**MODELS**

**SS4ULT, ULTD  
SS8T, TU TD, TD6  
SS8ULT, ULTD  
SS10T, TD  
SS10ULT, ULTD**

*(Auto-Fill)*

**SS8TDUIAF, CIAF  
SS10TDUIAF, CIAF**

**Includes  
INSTALLATION  
USE & CARE  
EXPLODED VIEW  
PARTS LIST  
WIRING DIAGRAM**

**IMPORTANT: DO NOT DISCARD THIS MANUAL**

This manual is considered to be part of the appliance and is to be given to the OWNER or MANAGER of the restaurant, or to the person responsible for TRAINING OPERATORS of this appliance. Additional manuals are available from your WELLS DEALER.

**THIS MANUAL MUST BE READ AND UNDERSTOOD BY ALL PERSONS USING OR INSTALLING THIS APPLIANCE.** Contact your WELLS DEALER if you have any questions concerning installation, operation or maintenance of this equipment.

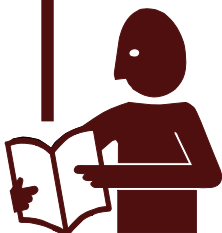

**LIMITED EQUIPMENT WARRANTY**

Wells Manufacturing warrants to the original purchaser of new Wells products to be free from defects in material or workmanship, under normal and proper use and maintenance service as specified by Wells and upon proper installation and start-up in accordance with the instructions supplied with each Wells unit. Wells' obligation under this warranty is limited to a period of one [1] year from the date of original installation, or eighteen [18] months from original invoice date, whichever occurs first. Defects that occur as a result of normal use, within the time period and limitations defined in this warranty, will at Wells' discretion have the parts replaced or repaired by Wells or a Wells-authorized service agency.

**THIS WARRANTY IS SUBJECT TO ALL LISTED CONDITIONS**

Repairs performed under this warranty are to be performed by a Wells authorized service agency. Wells will not be responsible for charges incurred or service performed by non-authorized repair agencies. In all cases, the nearest Wells-authorized service agency must be used. Wells will be responsible for normal labor charges incurred in the repair or replacement of a warranted product within 50 miles (80.5 km) of an authorized service agency. Time and expense charges for anything beyond that distance will be the responsibility of the owner. All labor will need to be performed during regular service hours. Any overtime premium will be charged to the owner. For all shipments outside the U.S.A. and Canada, please see the International Warranty for specific details. It is the responsibility of the owner to inspect and report any shipping damage claims, hidden or otherwise, promptly following delivery. No mileage or travel charges will be honored on any equipment that is deemed portable. In general, equipment with a cord and plug weighing less than 50 lb. (22.7 kg) is considered portable and should be taken or shipped to the closest authorized service agency, transportation prepaid.

**CONTACT**

Should you require any assistance regarding the operation or maintenance of any Wells Manufacturing; phone or email our service department. In all correspondence provide the model number and serial number of the unit needing service; include the voltage or gas type.  
 Normal Business Hours: 8:00 a.m. to 4:30 p.m. Central  
 Telephone: 800-264-7827 Tech Service Option 2  
 Email: [TechService@partstown.com](mailto:TechService@partstown.com)  
[www.Wells-Mfg.com](http://www.Wells-Mfg.com)

PRODUCTS	PARTS	LABOR
Universal Ventless Hoods (WVU)	1 year	1 year
Canopy Ventless Hoods (WVC)	1 year	1 year
"Cook and Hold" equipment (HW10, HWSMP, LLSC7, LLSC7WA, LLSC11, LLSC11WA)	1 years	1 year
Cast iron grates, burners and burner shields	1 year	
Original Wells parts sold to repair Wells Equipment	90 days	

**WARRANTY EXCLUSIONS**

**THE FOLLOWING WILL NOT BE COVERED UNDER WARRANTY.**

Wells' sole obligation under this warranty is limited to either repair or replacement parts, subject to the additional limitations detailed below. This warranty neither assumes nor authorizes any person to assume obligations other than those expressly covered by this warranty.

- Any product which has not been used, maintained, or installed in accordance with the directions published in the appropriate installation sheet and/or owner's manual, including incorrect gas or electrical connection. Wells is not liable for any unit which has been mishandled, abused, misapplied, subjected to harsh chemicals, modified by unauthorized personnel, damaged by flood, fire, or other acts of nature [or God], or which have an altered or missing serial number.
- Installation, labor, and job checkouts, calibration of heat controls, air and gas burner/bypass/pilot adjustments, gas or electrical system checks, voltage and phase conversions, cleaning of equipment, or seasoning of griddle surface.
- Replacement of fuses or resetting of circuit breakers, safety controls, or reset buttons.
- Replacement of broken or damaged glass components, quartz heating elements, and light bulbs.
- Labor charges for all removable and consumable parts in gas charbroilers and hotplates, including but not limited to burners, grates, and radiants.
- Any labor charges incurred by delays, waiting time, or operating restrictions that hinder a service technician's ability to perform service.
- Replacement of parts that fail or are damaged due to normal wear or labor for replacement of parts that can be replaced during a daily cleaning routine, such as but not limited to silicone belts, PTFE non-stick sheets, control labels, knobs, bulbs, fuses, quartz heating elements, baskets, racks, and grease drawers.
- Any economic loss of business or profits.
- Non-OEM parts. Use of non-OEM parts without Wells' approval will void the warranty.
- Units exceeding one [1] year from original installation date, or more than eighteen [18] months from original invoice date, whichever comes first.

**ADDITIONAL WARRANTIES**

- Specific/chain-specific equipment may have additional and/or extended warranties.

The foregoing warranty is in lieu of any and all other warranties expressed or implied and constitutes the entire warranty.

## TABLE OF CONTENTS

WARRANTY	xi
FEATURES & OPERATING CONTROLS	2
PRECAUTIONS & GENERAL INFORMATION	3
AGENCY LISTING INFORMATION	3
INSTALLATION	4
OPERATION	7-8
MAINTENANCE INSTRUCTIONS	9
CLEANING INSTRUCTIONS	10-11
TROUBLESHOOTING SUGGESTIONS	12
WIRING DIAGRAM	12-13
EXPLODED VIEW & PARTS LIST	
Non Auto-Fill Units	14
Auto-Fill Units	19
ACCESSORIES LIST	23
CUSTOMER SERVICE DATA	23

## INTRODUCTION

Thank You for purchasing this Wells appliance.

Proper installation, professional operation and consistent maintenance of this appliance will ensure that it gives you the very best performance and a long, economical service life.

This manual contains the information needed to properly install this appliance, and to use and care for the appliance in a manner which will ensure its optimum performance.

## SPECIFICATIONS

MODEL	VOLTS	AMPS	WATTS	POWER SUPPLY CORD
SS4T, TD, ULT, ULTD	120 VAC 1 $\emptyset$	6.9A	825W	NOT SUPPLIED
SS8T, TD, ULT, ULTD	208 VAC 1 $\emptyset$	3.0A	620W	
SS10T, TD, ULT, ULTD	240 VAC 1 $\emptyset$	3.4A	825W	

## FEATURES & OPERATING CONTROLS

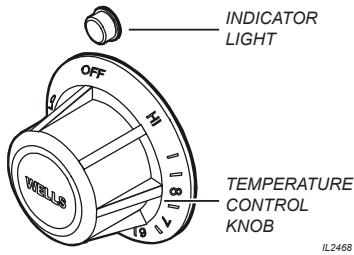

### A. THERMOSTAT

1. On THERMOSTATICALLY CONTROLLED warmers, power is applied to the heating element according to the control knob position and the actual temperature at the temperature sensing thermobulb.
2. The desired temperature is controlled by rotating the TEMPERATURE CONTROL KNOB. The knob has a numeric scale, where higher numbers correspond to higher temperature.
3. On warmers equipped with an INDICATOR LIGHT, the light will glow when the thermostat is calling for heat (i.e. the element is energized).
4. The TEMPERATURE CONTROL KNOB will rotate approximately 300°, and will reach a “stop” at both ends. The OFF position is marked.

**NOTE:** The dial position is an indication of the temperature setting. Actual temperature will vary depending upon the type of product and food consistency.

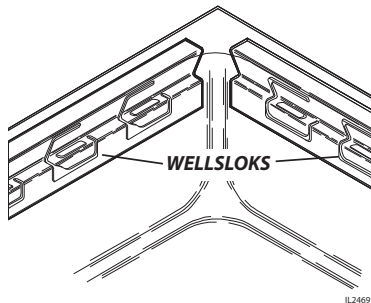

### B. MOUNTING

1. Top-mounted built-in warmers are equipped with WELLSLOKS, uniquely designed turnout tabs which help secure the warmer top flange to the countertop.
2. See the Installation Instructions, supplied with the particular appliance, for details.

### C. DRAINS

1. Models with a “D” (e.g. SS10TD) have drains for each well, with each well having an individual drain valve.
2. Models that have the individual drain lines manifolded together (custom installation), with a single drain valve for the entire manifold.

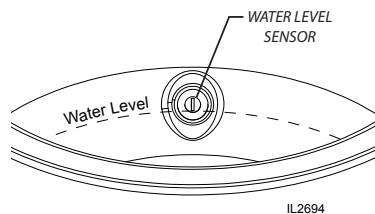
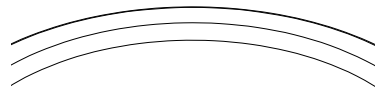

### D. AUTOFILL

1. On AUTOFILL units, water level is automatically fed into the “master” pan whenever that pan’s thermostat is ON.
2. Water level is sensed by a WATER LEVEL PROBE.

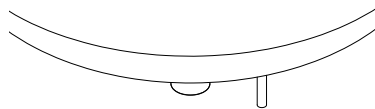

## PRECAUTIONS AND GENERAL INFORMATION

This appliance is intended for use in commercial establishments only.

This appliance is intended to hold pre-heated food for human consumption. No other use is recommended or authorized by the manufacturer or its agents.

Operators of this appliance must be familiar with the appliance use, limitations and associated restrictions. Operating instructions must be read and understood by all persons using or installing this appliance.

Cleanliness of this appliance is essential to good sanitation. Read and follow all included cleaning instructions and schedules to ensure the safety of the food product.

Disconnect this appliance from electrical power before performing any maintenance or servicing.

This appliance is not jet stream approved. Do not direct water jet or steam jet at this appliance, or at any control panel or wiring. Do not splash or pour water on, in or over any controls, control panel or wiring.

Exposed surfaces of this appliance can be hot to the touch and may cause burns.

Do not operate this appliance if the control panel is damaged. Call your Authorized Wells Service Agent for service.

The technical content of this manual, including any wiring diagrams, schematics, parts breakdown illustrations and/or adjustment procedures, is intended for use by qualified technical personnel.

Any procedure which requires the use of tools must be performed by a qualified technician.

This manual is considered to be a permanent part of the appliance. This manual and all supplied instructions, diagrams, schematics, parts breakdown illustrations, notices and labels must remain with the appliance if it is sold or moved to another location.

This appliance is made in the USA. Unless otherwise noted, this appliance has American sizes on all hardware.



### **WARNING: SHOCK HAZARD**

All servicing requiring access to non-insulated electrical components must be performed by a factory authorized technician.

**DO NOT** open any access panel which requires the use of tools. Failure to follow this warning can result in severe electrical shock.



### **CAUTION: RISK OF DAMAGE**

DO NOT connect or energize this appliance until all installation instructions are read and followed. Damage to the appliance may result if these instructions are not followed.



### **CAUTION: HOT SURFACE**



Exposed surfaces can be hot to the touch and may cause burns.

## AGENCY LISTING INFORMATION

Refer to the *product nameplate* for the specific appliance for agency listings. In general:

This appliance conforms to NSF Standard 4 for sanitation only if installed in accordance with the supplied *Installation Instructions*.

UL Listed warmers are  Listed under UL File E6070.

Underwriters Laboratory recognized () warmers (UL File E6070) - Since the warmer is only a single component of a complete installation, the finished installation of an  unit requires additional evaluations to Underwriters Laboratory standards.



STD 4



E6070

UL Listed Warmers



E6070

UL Recognized Warmers

## INSTALLATION

**NOTE:** DO NOT discard the carton or other packing materials until you have inspected the appliance for hidden damage and tested it for proper operation.

Refer to *SHIPPING DAMAGE CLAIM PROCEDURE* on the inside front cover of this manual.



### **WARNING: RISK OF INJURY**

Installation procedures must be performed by a qualified technician with full knowledge of all applicable electrical and plumbing codes. Failure can result in personal injury and property damage.



### **CAUTION FIRE HAZARD**

Avoid storing flammable or combustible materials in, on or near the appliance.

**IMPORTANT:** For warmers installed in plastic counter tops, the counter material must be protected from the heat of the warmer in order to prevent discoloration and/or deterioration. Wellsloks are not suitable for this purpose. The installer should contact the manufacturer or distributor of the countertop material for specific instructions.

**IMPORTANT:** Wellslok Extension Kits must be used ONLY with UL Listed warmers approved for installation in wood counter tops. Refer to the *Installation Instructions* provided with the warmer.

## UNPACKING & INSPECTION

Carefully remove the appliance from the carton. Remove all protective plastic film, packing materials and accessories from the Appliance before connecting electrical power or otherwise performing any installation procedure.

Carefully read all instructions in this manual and the *Installation Instruction Sheet* packed with the appliance before starting any installation.

Read and understand all labels and diagrams attached to the appliance.

Carefully account for all components and accessories before discarding packing materials. Store all accessories in a convenient place for later use.

## INSTALLATION NOTES

1. Installation and start up of built-in warmers MUST be performed by an authorized installation company.
2. It is the RESPONSIBILITY OF THE INSTALLER to verify that this warmer installation is in compliance with the specifications listed in this manual and on the specification sheet provided.
3. It is the RESPONSIBILITY OF THE INSTALLER to check with the AUTHORITY HAVING JURISDICTION, in order to verify that this warmer installation is in compliance with local code requirements.
4. Water supply and drain installation must meet all applicable local, state and federal plumbing codes and ordinances.
5. Refer to Installation Instructions included with the warmer for Underwriters Laboratories conditions of acceptability, electrical requirements and other installation concerns.

## BUILT-IN WARMERS

1. This is a GENERAL GUIDE. For specific cutout dimensions and other installation details, refer to the Installation Instructions supplied with the warmer.
2. Cutout dimensions for warmer units and control panels are listed on the Installation Instructions provided with the warmer.
3. Verify style of control panel (e.g oval, rectangular) before making cutout.
4. Units that are being connected by a manifold system, all units MUST be installed on a level surface and with each other. If the units are being installed on a mobile cart, the cart MUST be positioned on a level surface when put in use.

**NOTE:** Cutout dimensions are different for insulated and non-insulated units, control panels, for UL LISTED units and UL Recognized units, and for wood and metal counters. Verify the dimensions are correct for the installation before making the cutout. Specific cutout specifications are list on the installation sheet included with the unit.

## INSTALLATION continued

4. For “top-mounted” warmers (i.e. warmers mounted from above the counter top):
  - a. Verify that provided sealants are applied to the underside of the warmer top flange prior to setting the unit into the cutout.
  - b. After installation, verify that the tabs on the Wellsloks are turned out to lock the warmer into the counter
  - c. Apply a thin bead of food-grade silicone sealant around the flange to seal it to the counter.
  - d. Wellslok extension kits are available for installing warmers in counter tops where the standard Wellslok would not normally reach. The extension kit will adapt to counter tops up to 1¾” thick.

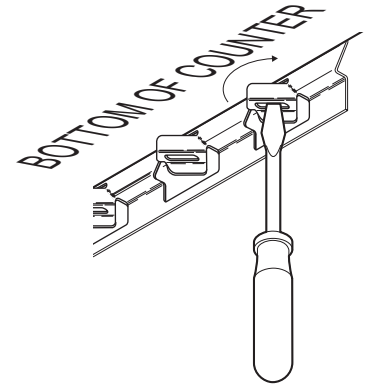

### ELECTRICAL INSTALLATION

1. Refer to the product nameplate. Verify the electrical service power. Voltage and phase must match the nameplate specifications. Wiring the warmer to the wrong voltage can severely damage the unit or cause noticeably decreased performance.
2. Available electrical service amperage must meet or exceed the specifications listed on the specification sheet provided with the warmer.
3. Warmer and control unit must be connected to an appropriate building ground. Ground connection will be marked “GND” or “

**NOTE:** Wire gauge, insulation type and temperature rating, as well as type, size and construction of conduit, must meet or exceed applicable specifications of local codes and of the National Electrical Code.

**NOTE:** Damage caused by leaks due to improper installation is NOT covered by warranty.



### CAUTION: SHOCK HAZ- ARD

The ground lug of this appliance must be connected to a suitable building ground.

### IMPORTANT:

Contact a licensed electrician to install and connect electrical power to the appliance.

### IMPORTANT:

Damage due to being connected to the wrong voltage or phase is NOT covered by warranty.

**IMPORTANT:** Electrical installation other than as specified on the specification sheet will void the UL listing, and may void the warranty.

**NOTE:** Plumb connections must be made in compliance with all Federal, State and Local Plumbing Codes and Ordinances.



## INSTALLATION continued

**NOTE:** Plumb connections must be made in compliance with all Federal, State and Local Plumbing Codes and Ordinances.



### **WARNING: RISK OF INJURY**

While local plumbing codes may allow the use of pvc, cpvc, abs or other plastic pipe for drain connections. **DO NOT** attach a plastic drain to the bottom of the food warmer. These units will contain water with temperatures in excess of 180°F and localized metal temperatures in excess of 275°F (135°C). Failure to follow these directions may result in personal injury and property damage.

### **PLUMBING INSTALLATION**

For use in the State of Massachusetts, this appliance must be installed in compliance with **Massachusetts Fuel Gas and Plumbing Code CMR 248**.

1. **IMPORTANT:** All plumbing installations must be performed by a qualified plumber.
2. For units equipped with a **DRAIN LINE:** Some jurisdictions may require an approved air gap or other back-flow prevention device in the drain. It is the responsibility of the plumber to determine such requirement, to provide and properly install the required device.
3. For SS4, SS8 and SS10 DRAIN LINE units, the drain must be attached with a union at the drain line fitting. This is necessary to provide for future maintenance of the heating element.
4. **AUTOFILL** units require a drain valve (not supplied by Wells) to be installed in order to operate correctly.
5. For **AUTOFILL** units: Some jurisdictions may require an approved back-flow preventer in the water supply line. It is the responsibility of the plumber to determine such requirement, and to provide and properly install the required device.  
Autofill supply must be connected to a COLD WATER line only.
6. **AUTOFILL** tee fitting can be installed with the drain facing down or turned 90° to manifold (not supplied) to another **non-AUTOFILL** unit.



## OPERATION

### WET OR DRY OPERATION for WARMERS

1. Carefully read the description of the warmer operation on the specification sheet.
2.
  - a. Most warmers are designed for WET OR DRY operation, except **AUTOFILL** units..
  - b. Warmers may be used wet, or may be used dry. However warmers may NOT be used wet-to-dry or dry-to-wet unless they have been allowed to cool to room temperature between the change in wet or dry operation.
  - c. Wells Manufacturing recommends operating WET for consistent food heating.
  - d. If your wet-operation warmer is allowed to run dry, turn it OFF and allow to cool to room temperature before adding water.
3. If the warmer is to be used for WET operation, add approximately 1" of hot tap water before turning the warmer on. Use of hot water will allow a faster preheat.
  - a. Check the water level frequently and add hot water as necessary to prevent the warmer from running dry. Do not add water to the warmer if it has run dry.
  - b. If your wet-operation warmer is allowed to run dry, turn it OFF and allow to cool to room temperature before adding water.
4. Damage caused by allowing a wet-operation warmer to run dry, is NOT covered by warranty. Damage caused by adding water to a dry warmer when hot is NOT covered by warranty.

### PRE-HEATING THE WARMER

1. Place desired pan(s) or inset(s) with appropriate adapter top on warmer.
  - a. Insets are available as accessories in 2½ qt., 4qt., 7 qt., and 11 qt. sizes with lids and adapter tops.
  - b. For dry operation, a 6" deep pan or inset is recommended.
2. Turn temperature control to HI or highest temperature setting.
3. Allow warmer to preheat for approximately 30 minutes, then set the control for the desired temperature. Be sure to keep the warmer covered during preheat and operation.



### CAUTION: HOT SURFACE

Exposed surfaces can be hot to the touch and may cause burns.



### CAUTION: SHOCK HAZARD

DO NOT splash or pour water onto control panel or wiring.

Always use an inset.

**DO NOT** place food directly into the warmer.

Always pour hot water into the warmer before it is preheated.

**DO NOT** pour water into a dry, heated warmer. This may damage the unit.

**DO NOT** put ice into a warmer pan. This will cause condensation on the inside of the warmer. Damage caused by condensation is **NOT** covered by warranty.

Stir thick food items frequently to keep food heated uniformly.

Keep insets covered to maintain food quality and temperature.

## OPERATION continued

### CAUTION: HOT SURFACE

Exposed surfaces can be hot to the touch and may cause burns.



### CAUTION: SHOCK HAZARD

DO NOT splash or pour water onto control panel or wiring.

Always use an inset.

DO NOT place food directly into the warmer.

Always pour hot water into the warmer before it is preheated. **DO NOT** pour water into a dry, heated warmer. This may damage the unit.

**DO NOT** put ice into a warmer pan. This will cause condensation on the inside of the warmer. Damage caused by condensation is **NOT** covered by warranty.

Stir thick food items frequently to keep food heated uniformly.

Keep insets covered to maintain food quality and temperature.

### AUTOFILL WARMERS

1. Autofill warmers sense water level by a sensor placed at the proper level. For manifolded autofill warmers, the water level sensor / fill tube is in one pan only.
2. Water fills the pan through an inlet tube. All other sections if manifolded, fill at the same time through the drain manifold.
3. The autofill function is active only when the thermostat for the pan with the water level sensor is turned ON .
4. Make sure the drain valve is fully closed before turning any t-stats ON.
5. DO NOT use autofill warmers in the dry mode. This may damage the water level sensor probe. NEVER turn the thermostat ON for the pan with the probe and fill tube unless the entire warmer unit is to be used in the wet mode.
6. Clean water level sensor daily to maintain water level in warmer.

### OPERATION

1. Always use an inset. DO NOT place food directly into the warmer.
2. Check water level in wet-operation warmer frequently during use. Running warmers dry will lower the temperature of the food in the insert pan, and may damage the warmer.
3. Alternating between wet and dry operation in any individual warmer is NOT recommended.
4. DO NOT use metal tools, steel wool, or caustic or abrasive cleanser to clean warmer pan.

### WARMERS WITH MANIFOLDED DRAIN

1. Water poured into any one section will seek the same water level with all sections on the manifold.
2. Make sure the drain valve is fully closed before filling warmer.
3. All units that are manifolded with the AUTOFILL unit, MUST be on the same elevation and completely level with each other to operate correctly.

## MAINTENANCE INSTRUCTIONS

### CARE OF STAINLESS STEEL

Stainless steel is a marvelous material: strong, lustrous and low maintenance. With a minimum of care, it will normally retain its beauty and durability for the life of the equipment. In some applications, however, special care is required in order to maintain stainless steel's special properties.

External components, such as cabinets and control panels, are finished with a grain pattern. This pleasing finish is best maintained by cleaning with a non-abrasive cleanser applied with a soft cloth. Rub only in the direction of the grain. In the absence of visible grain, rub only along the longest axis of the appliance.

Restore stainless steel's luster by applying a polish specifically made for stainless steel. Spray on, wipe off with a soft cloth, rubbing in the direction of the grain.

**Never use metal implements, wire brushes, abrasive scratch pads or steel wool to clean stainless steel.**

Warmer pans, insets and other vessels are subject to a harsher environment. Wells Manufacturing uses an very high quality stainless steel (#304DDQ) for our food warmer pans. Even the highest quality stainless steel, however, is mostly iron, and will rust, pit and corrode under the following conditions:

- **Poor Water Quality:** Hard water (water with a high content of dissolved minerals) will leave mineral deposits when allowed to dry. Calcium (lime) can buildup on heated surfaces, even under water. If left unattended, hard water spots and lime buildup can lead to rusting, corrosion and pitting.
- **Contact with Chlorides:** Chlorides (specific compounds of chlorine) are found in food, table salt and many cleansers. Chlorides can attack the surface of stainless steel, resulting in corrosion and pitting.

Keep your stainless steel warmers clean and free from calcium buildup.

Use alkaline, alkaline chlorinated or non-chloride cleanser.

Use citric acid-based cleaners to remove calcium deposits.

For additional information, please read the NAFEM Stainless Steel Equipment and Cleaning Guide. Contact NAFEM at :

North American Association of Food Equipment Manufacturers

401 N. Michigan Avenue

Chicago, Illinois 60611-4267

(312) 644-6610

## CLEANING INSTRUCTIONS



### CAUTION: SHOCK HAZARD

Do NOT splash or pour water into or over any control panel or wiring.



### CAUTION: SHOCK HAZARD

Disconnect warmer from electric power before cleaning



### CAUTION: BURN HAZARD

Allow warmer to cool completely before cleaning.

### DAILY CLEANING INSTRUCTIONS

**PREPARATIONS:** Turn control knob(s) to OFF. Allow warmer to cool before proceeding.  
Remove any insets, pans and/or adapter tops.  
Drain or remove water from well if used for wet operation.

**FREQUENCY:** Minimum - daily.

**TOOLS:** Mild Detergent  
Solution: 10 Parts Warm Water to 4 Parts Vinegar  
Plastic Scouring Pad  
Clean Cloth or Sponge  
Food-Grade Silicone Sealant

1. Wipe entire unit down using a clean cloth or sponge and mild detergent.
2. Use a plastic scouring pad to remove any hardened food particles or mineral deposits.  
**IMPORTANT: DO NOT** use steel wool for cleaning.
3. Rinse warmer thoroughly with a vinegar and water solution to neutralize all detergent cleanser residue.
4. Inspect warmer flange-to-counter seal. Reseal with food-grade silicone sealant if necessary. Failure to do so may allow grease and water to leak into insulation and heating element, causing a potential fire and/or electric shock hazard.
5. Inspect warmer tank for damage. Damage to the outer body may allow grease and water to leak into insulation and heating element, causing a potential fire and/or electric shock hazard. Contact your Authorized Wells Service Agency to inspect warmer if water or grease contamination is suspected.
6. Close drain valve. Add proper amount of warm water. Turn control knob(s) ON and check for proper operation.

## CLEANING INSTRUCTIONS

### WEEKLY CLEANING INSTRUCTIONS

**PREPARATIONS:** Remove any insets, pans and/or adapter tops. Drain or remove water from well if used for wet operation.

**FREQUENCY:** Weekly, or whenever lime or scale is seen accumulating on the sides of the warmer pans.

**TOOLS:** Commercial Delime Cleaner  
Plastic Scouring Pad  
Clean Cloth or Sponge



### CAUTION: CHEMICAL BURN HAZARD

Deliming chemicals may be caustic. Wear appropriate personal protective equipment. Follow cleaner manufacturer's instructions for safest use.

1. Add water to pans until water is at normal operating level (1" - 1 1/2" deep) or covers accumulated scale.
2. Heat water to maximum temperature (190°F or higher).
3. Pour contents of one package of commercial delime cleaner into each warmer pan. Stir to dissolve cleaner. Turn heat control OFF. Cover pans.
4. Allow solution to soak at least one hour, or overnight for heavy scale buildup.
5. Drain hot water from pans. Scrub with a plastic scouring pad. Rinse thoroughly with hot water, then dry.
6. Refill pans with hot tap water and resume operation.
7. Heavy scale buildup may require additional treatments.

## TROUBLESHOOTING SUGGESTIONS

SYMPTOM	POSSIBLE CAUSE	SUGGESTED REMEDY
No power to warmer	Circuit breaker off or tripped	Reset circuit breaker
Warmer will not heat	Temperature control not set	Set control to desired temperature
Warmer trips circuit breaker	Wet insulation	Verify flange-to counter seal is sound, or reseal with food-grade silicone sealant
	Pan leaking or other internal damage	Contact your Authorized Wells Service Agency for repairs
	Internal damage	Contact your Authorized Wells Service Agency for repairs
Warmer slow to heat	Mineral deposits on pan acting as an insulator	Clean pan(s) with delime cleaner
	Wired to wrong voltage	Verify supply voltage - must match voltage on warmer nameplate
Drain-equipped unit will not hold water	Drain valve not fully closed	Check drain valve for debris and close fully
	Drain valve damaged or pan(s) leaking	Contact your Authorized Wells Service Agency for repairs
Auto-fill unit overflows	Water level sensor dirty	Clean water level sensor
	Internal damage	Contact your Authorized Wells Service Agency for repairs
Auto-fill unit does not fill	Water supply turned off or restricted	Be sure water supply is turned on and water supply hose is not pinched or twisted
	Bad Probe or other Internal Damage	Contact your Authorized Wells Service Agency for repairs
One or more pans of an auto-fill unit do not fill	Blocked drain manifold	Clean drain manifold

There are no user-serviceable components in this appliance.  
 In all instances of damage or malfunction, contact your Authorized Wells Service Agency for repairs.

## WIRING DIAGRAM - AUTOFILL

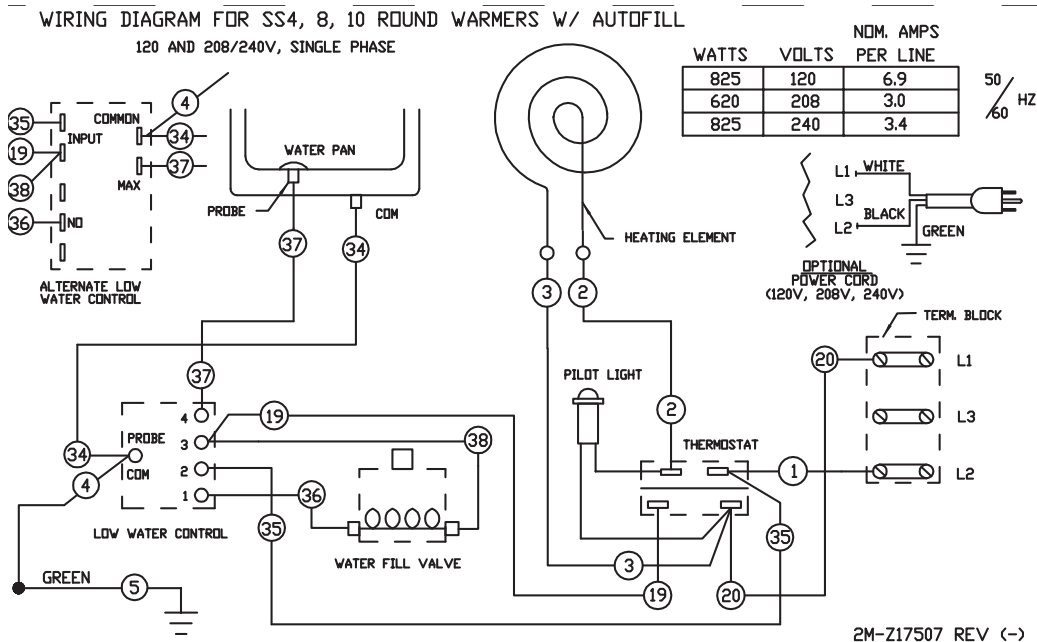

# WIRING DIAGRAM

## WIRING DIAGRAM FOR SS-WARMERS 120 OR 208/240V, SINGLE PHASE

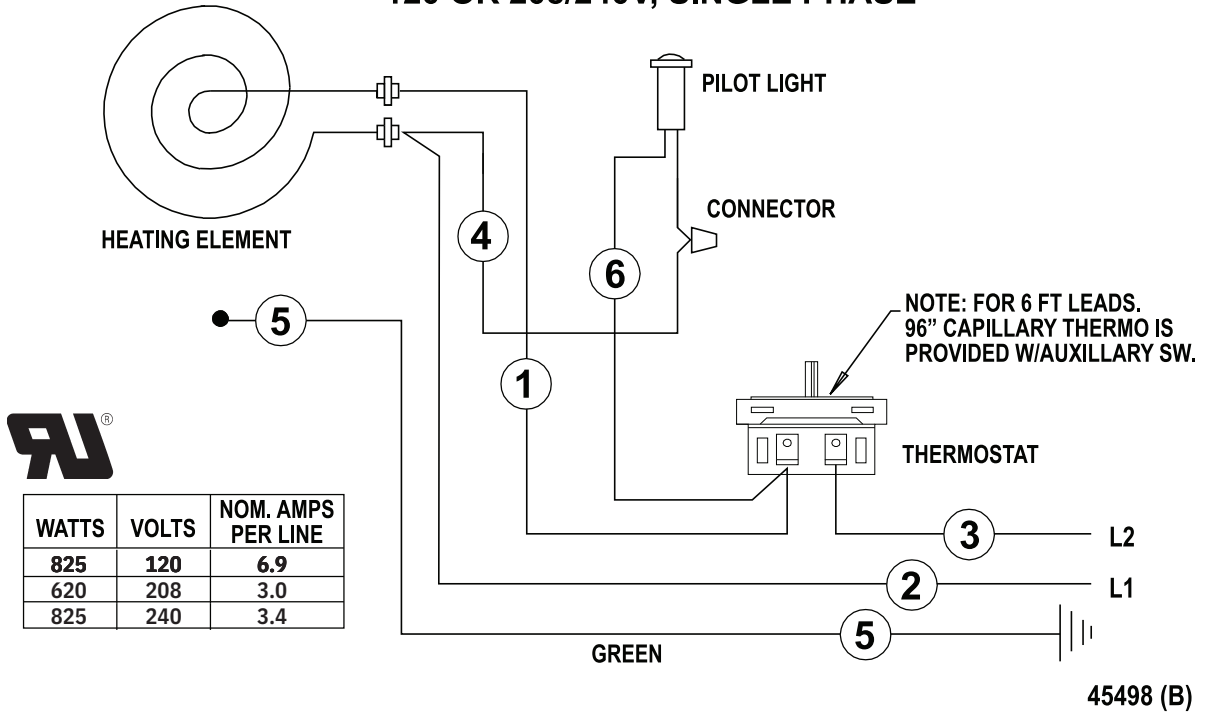

## WIRING DIAGRAM FOR SS4ULT(C); SS8ULT(C); SS10ULT(C) 120 OR 208/240V SINGLE PHASE WITH OR WITHOUT OPTIONAL POWER CORD

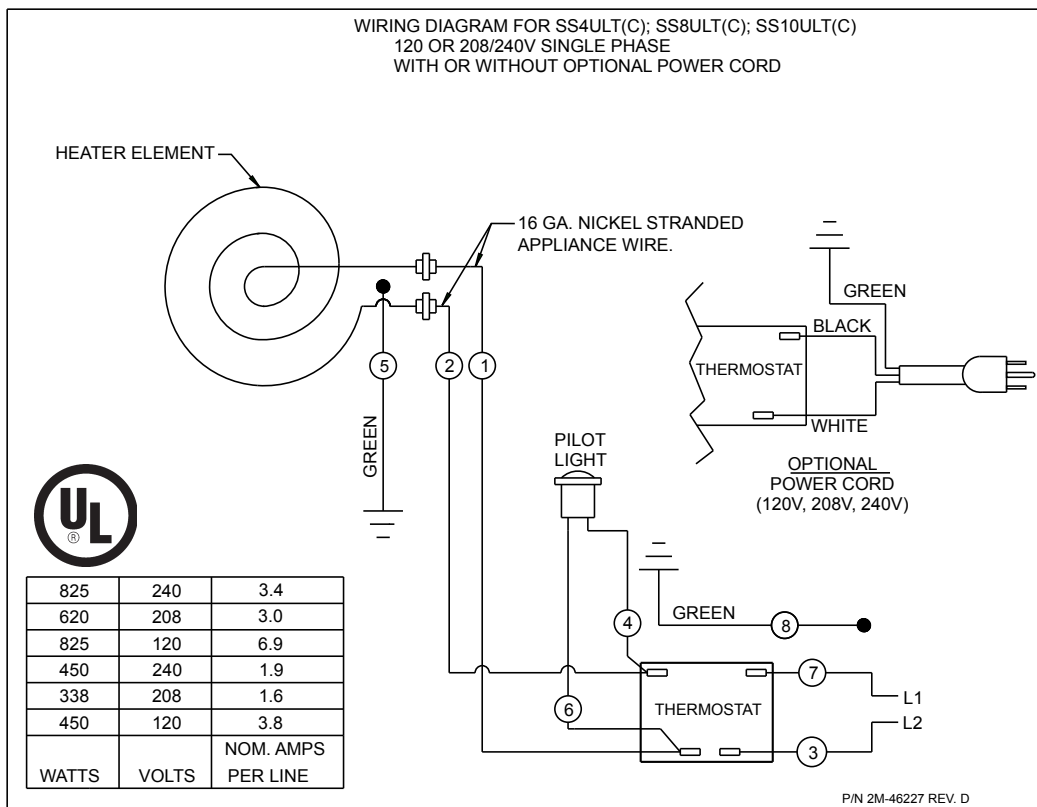

M011D.01 2M-Z17558 Owners Manual for Built-In Round T-Stat Warmers



# EXPLODED VIEW & PARTS LIST

SS8T and SS10T with & without Drain

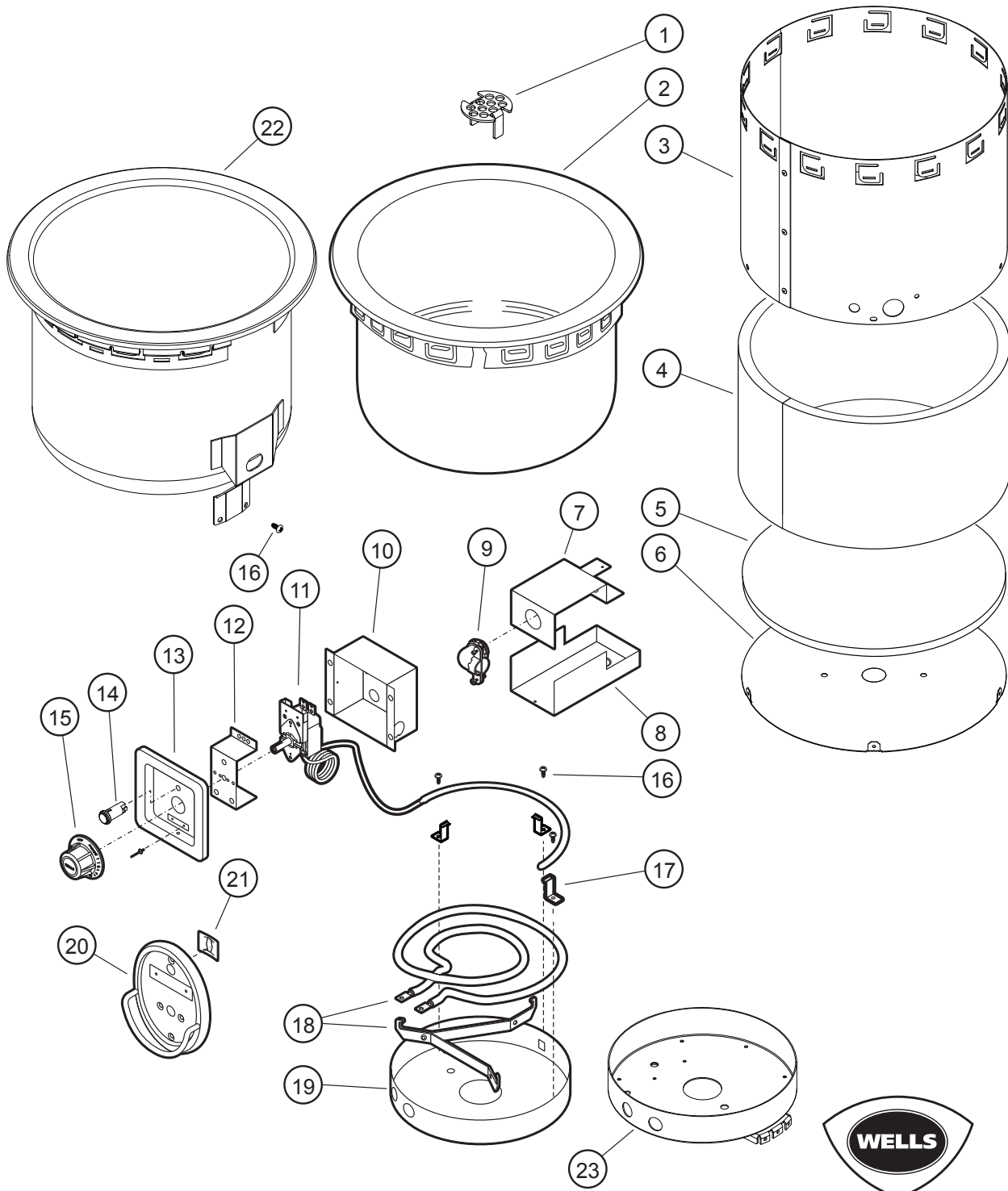

**Model:** SS4T, SS8T & SS10T (w & w/o Drain)  
 SS4TU, SS8TU & SS10TU (w & w/o Drain)

IL1904 Rev. F 4/08/15

M011D.01 2M-Z17558 Owners Manual for Built-In Round T-Stat Warmers

## PARTS LIST

**SS4T, SS8T & SS10T units with & without drain**

April 08, 2015, Rev B

### Model: SS4T, SS8T, SS10T (Insulated & non-insulated) with & without Drian

Fig No	Part No.	Description	Qty	Application
1	2V-Z17446	Drain Screen	1	Drain Units
2	WS-63527	Pot Assembly	1	SS4ULT
	WS-50391			SS8ULT, SS8T
	WS-51232			SS10ULT, SS10T
	WS-63528	Pot Assembly w/Drain		SS4ULTD
	WS-50504			SS8ULTD, SS8TD
	WS-50392			SS10ULTD, SS10TD
	P2-WL0292	Pot Assembly Insulated		SS4TUI
	P2-WL0290			SS8TUI
	P2-WL0288			SS10TUI
	P2-WL0291	Pot Assembly Insulated w/Drain		SS4TDUI
	P2-WL0289			SS8TDUI
P2-WL0287	SS10TDUI			
3	P2-WL0321	COVER, SIDE INSUL RIVETED	1	SS4I, manufactured before 4/2015
	P2-WL0714			SS4I, manufactured on or after 4/2015
	P2-WL0316			SS8I
	P2-WL0314			SS10I
4	2H-Z16125	Insulation, Side SS4I	1	SS4I
	2H-Z16063	Insulation, Side SS8I		SS8I
	2H-Z15568	Insulation, Side SS10I		SS10I
5	2H-Z16062	INSULATION, BOTTOM	1	SS4I, SS8I
	2H-Z15567			2
6	P2-Z16122	COVER, BOTTOM INSULATION	1	SS4I
	P2-Z16060			SS8I
	P2-Z15570			SS10I
7	P2-WL0323	BOX OUTLET	1	SS4, SS8, SS10, SS4T, SS8T, SS10T
	P2-Z16089			SS4I, SS8I
8	P2-31862	OUTLET BOX COVER	1	
9	2K-34136X	FTG FLEX CON 90° X 1/2" MOD	1	CONDUIT UNITS
	2K-37748X	FTG CONDUIT STRAIGHT 3/8		
10	P2-Z16805	CONTROL BOX	1	CONDUIT UNITS
11	2T-46269	THERMOSTAT CONTROL	1	SS4TU, TUC, TUCI, TDU, TDUC, TDUCI, SS8EUT-230V, SS8TU, TUC, TDUC, SS10T-230V, SS10TD-230V, TU, TUC, TDUC, TDUCI
	2T-46551	THERMO CTRL 96IN CAP		SS4ULT6, SS4TDUI6, SS8ULT6, SS8TDUC6-120
	P2-Z16162	THERMOSTAT , FORMED		SS10I
	P2-Z16163	BULB		SS8I
	P2-Z16754	THERMOSTAT FORM 96"		SS10TDUCI612, SS10TUCI6120, SS10TDUI6, SS10TDUI6120
	P2-Z16942	THERMOSTAT 96"		SS8TDUCI6120, SS8TUCI6-120, SS8TUCI6, SS8TDUCI6, SS8TDUI6
	WS-60282	THERMO CONTROL		SS4T, SS4TD, SS8T, SS8TD, SS10T,

M011D.01 2M-Z17558 Owners Manual for Built-In Round T'Stat Warmers

## PARTS LIST

**SS4T, SS8T & SS10T units with & without drain**

April 08, 2015, Rev B

### Model: SS4T, SS8T, SS10T (Insulated & non-insulated) with & without Drian

Fig No	Part No.	Description	Qty	Application
12	P2-40843	THERMOSTAT MOUNTING BRKT	1	
13	I7-Z12221	CONTROL PANEL	1	
14	2J-35687	LIGHT SIGNAL	1	
15	2R-40498	CONTROL KNOB ASSY	1	
16	2C-33935	SCREW	3	
17	D8-306439	CLAMP BULB	3	SS4, SS8, SS10, SS4T, SS8T, SS10T
	P2-Z16136			SS4I
	P2-Z16036			SS10I
	P2-Z16036		4	SS8I
18	WS-506272	KIT, ELEMENT & SUPPORT	1	120V
	WS-506273			208/240V
19	WS-51878	ELEMENT COVER	1	
20	2V-WL0049	PANEL, CONTROL OVAL/ GUARD	1	
21	2C-20602-03	CLIP RETAINER PILOT LIGHT	1	
22	P2-WL0718	Pot Assembly	1	SS4ULT
	P2-WL0760			SS8ULT, SS8T
	P2-WL0758			SS10ULT, SS10T
	P2-WL0717	SS4ULTD		
	P2-WL0761	Pot Assembly w/Drain		SS8ULTD, SS8TD
	P2-WL0759	SS10ULTD, SS10TD		
	P2-WL0716	Pot Assembly Insulated		SS4TUI
	P2-WL0715	Pot Assembly Insulated w/Drain		SS4TDUI
23	P2-WL0719	ASM-ELM MTG	1	SS4I
	P2-WL0691			SS4, SS8
	P2-WL0757			SS10
NI	P2-40634	CONDUIT, FLEX 1/2" X 28"	1	
	P2-47595	CONDUIT 6" FOOT		SS4TDUI6-120, SS8TU6, SS8TDUC6-120, SS8TDUCI6, SS8TDUCI6120, SS10TDUI6
NI	P2-Z15643	CORDSET-14/3, 6-15P, 208/240V	1	208/240V CORDED UNITS
NI	P2-Z15641	CORDSET-14/3, 5-15P, 120V	1	120V CORDED UNITS

M011D.01 2M-Z17558 Owners Manual for Built-In Round T'Stat Warmers

# EXPLODED VIEW AUTO-FILL

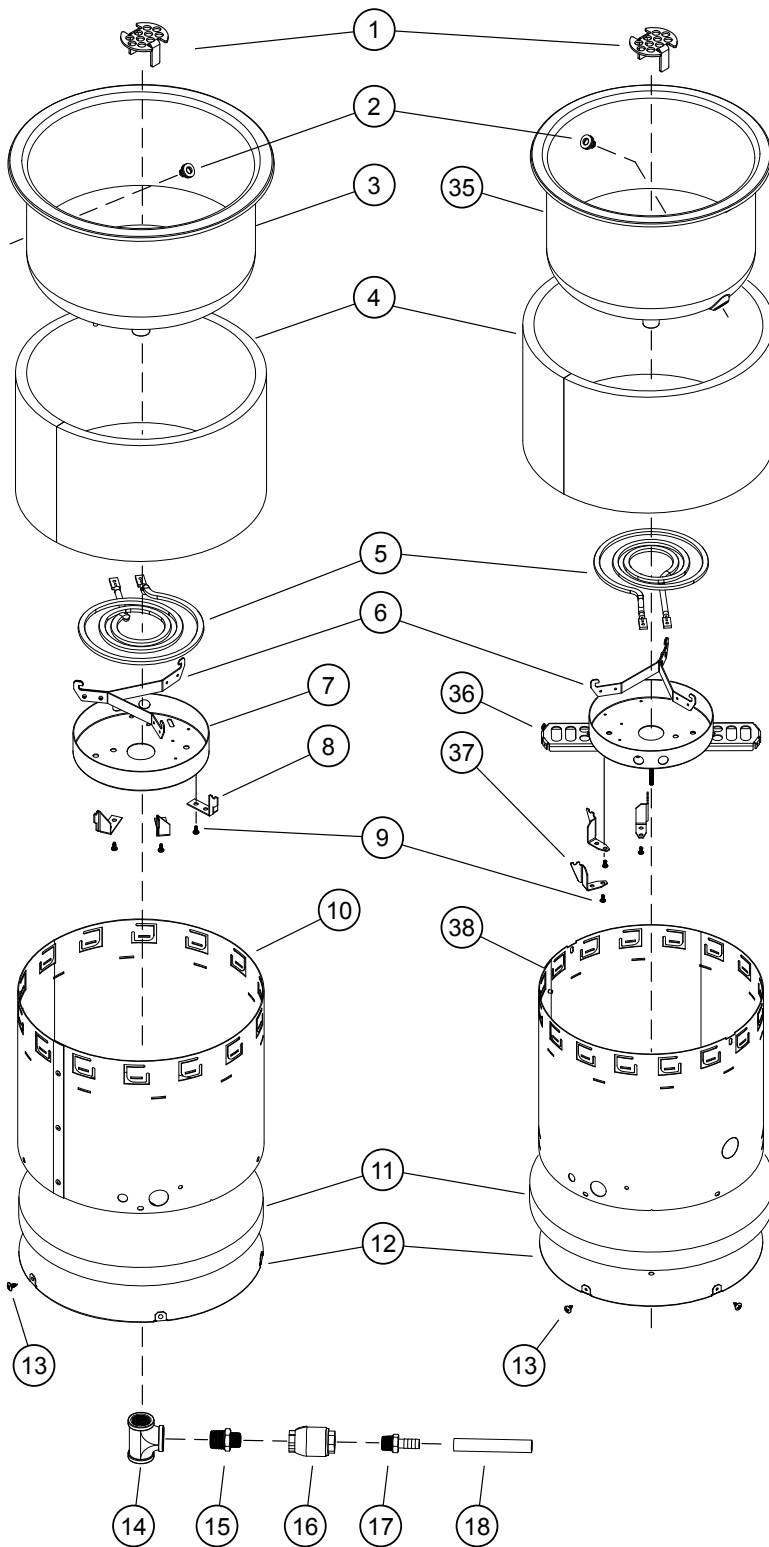

SEE DETAIL A

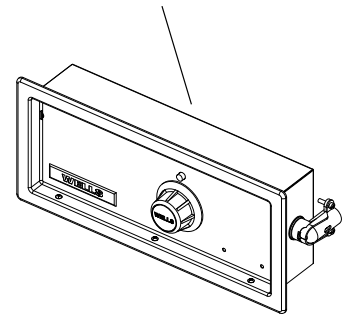

Model: SS10TDUIAF (w Drain & AUTO-FILL)

SK2697, Rev. A, 4/09/15

M011D.01 2M-Z17558 Owners Manual for Built-In Round T-Stat Warmers

# EXPLODED VIEW AUTO-FILL: Detail A

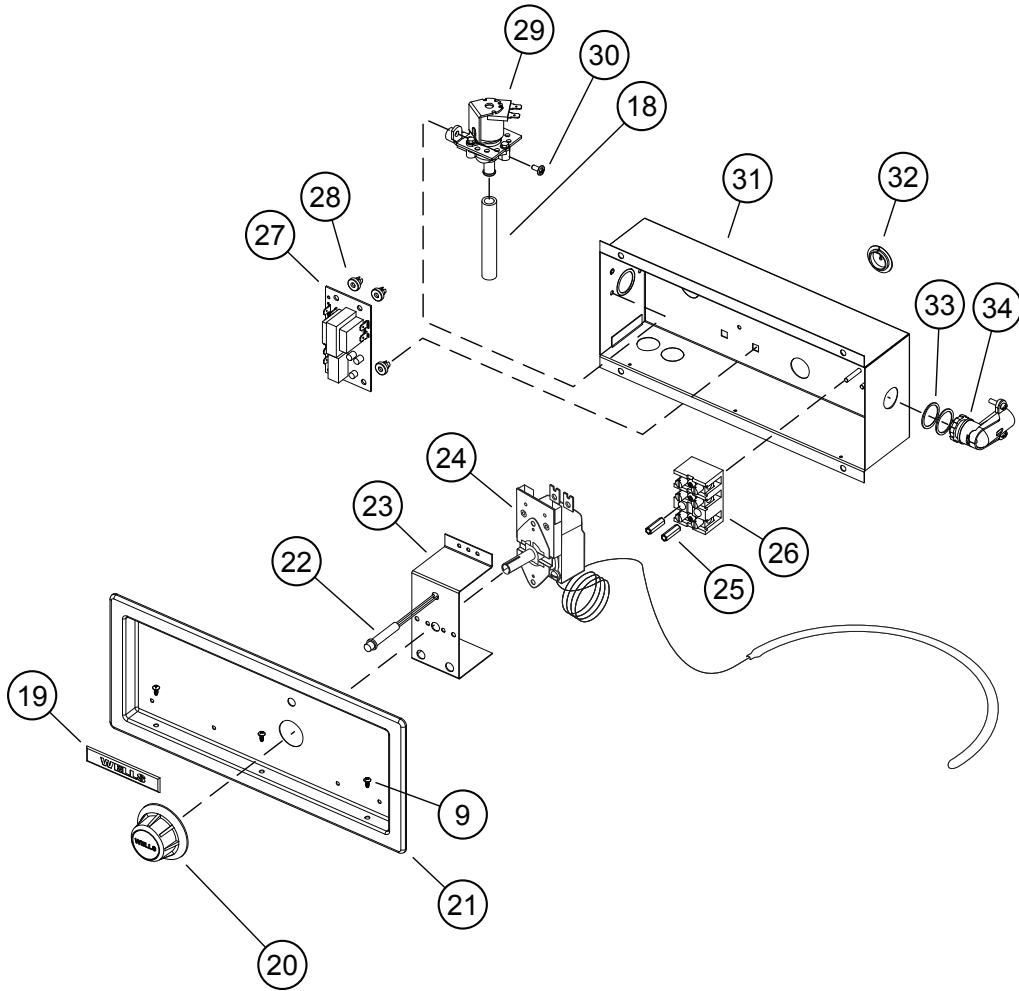

**DETAIL A**

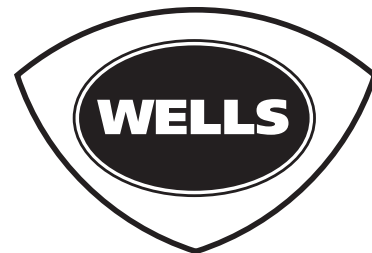

**Model:** SS10TDUIAF (w Drain & AUTO-FILL)  
CONTROL PANEL ASSEMBLY

SK2893 Rev. - , 4/09/15

M011D.01 2M-Z17558 Owners Manual for Built-In Round T-Stat Warmers

## PARTS LIST AUTO-FILL

**SS8TDUIAF & SS10TDIAF units with drain & Autofill**

April 08, 2015, Rev B

### Model: SS8TDUIAF, CIAF & SS10TDUIAF, CIAF AUTO-FILL

Fig No.	Part No	Quantity	Description	Application
1	2V-Z17446	1	DRAIN SCREEN	SS10TDUIAF
2	P2-WL0453	1	ASM-SENSOR WATER LEVEL-AF	
3	P2-WL0446	1	POT ASM-SS10 AUTOFILL	SS10TDUIAF
	P2-WL0447		POT ASM-SS8 AUTOFILL	SS8TDUIAF
4	2H-Z15568	1	INSULATION, SIDE	SS10TDUIAF
	2H-Z16063			SS8TDUIAF
5	2N-306273UL	1	ELEM 240V 825W SS-8T 10T	208/240V
	2N-306272UL		ELEM 120V 825W SS-8T 10T	120V
6	P2-306497	1	ASSY ELEM SPACER/SUPPORT	
7	P2-Z16200	1	COVER, ELEMENT INSULATED	
8	P2-Z16036	3	CLAMP, BULB	SS10TDUIAF
		4		SS8TDUIAF
9	2C-33935	8	SCREW 6ABX5/16 PH PAN SMS	SS8TDUIAF
		9		SS10TDUIAF
10	P2-WL0314	1	COVER, SIDE INSUL RIVETED	SS10TDUIAF
	P2-WL0316		ASM-COVER INSL SIDE SS8AF	SS8TDUIAF
11	2H-Z15567	2	INSULATION, BOTTOM SS10I	SS10TDUIAF
	2H-Z16062	1	INSULATION, BOTTOM SS8I	SS8TDUIAF
12	P2-Z15570	1	COVER, BOTTOM INSULATION	SS10TDUIAF
	P2-Z16060			SS8TDUIAF
13	2C-1646	5	SCREW #8X3/8 AB THP STL	SS10TDUIAF
		6		SS8TDUIAF
14	2K-Z17555	1	FTG-TEE 1/2X1/2X1/2F NPT	
15	2K-Z17556	1	FTG-REDUCING M 1/2X3/8NPT	
16	2V-47650	1	VALVE ANTISYPHON 3/8	
17	2K-47662	1	FTG STR BRS 3/8NPT X3/8IN	
18	P2-46587	1	HOSE MOD AUTOFILL 36 IN	
	P2-46587A		HOSE MOD AUTOFILL 72 IN	SS10TDUCIAF6, SS10TDUIAF6
19	2M-49919	1	LOGO DOMED BUILT-IN C. PA	
20	2R-40498	1	KNOB ASSY MOD 100DT	
21	P2-Z12587	1	PANEL, CONTROL MOD100 TDM	
22	2J-35687	1	LIGHT SIGNAL GLO DOT W#8	
23	P2-40843	1	BRKT MTG THERMO INFINITE	
24	P2-Z16162	1	THERMOSTAT, FORMED BULB	SS10TDUIAF, SS10TDUCIAF, SS10TDUCIA12, SS10TDUIAF6
	P2-Z16163			SS8TDUIAF, SS8TDUCIAF, SS8TDUCIAF12
25	2C-41974	2	NUT 8-32 HEX 7/8 LONG ALU	
26	2E-37465	1	TERM BLOCK 3POLE 85AMP	

M011D.01 2M-Z17558 Owners Manual for Built-In Round T-Stat Warmers

## PARTS LIST AUTO-FILL continued

**SS8TDUIAF & SS10TDIAF units with drain & Autofill**

April 08, 2015, Rev B

### Model: SS8TDUIAF, CIAF & SS10TDUIAF, CIAF AUTO-FILL

Fig No.	Part No	Quantity	Description	Application
27	2E-306865	1	CONTROL LIQ LEVEL 208/240	208/240V
	2E-46604		CONTROL LIQ LEVEL 120V	120V
28	2I-40034	4	GROMMET SCREW T4	
29	2E-46529	1	SOLENOID VALV 1/4NPT 240	208/240V
	2E-Z17361		SOLENOID VALV 1/4NPT 120V	120V
30	2C-200014	2	SCREW 8-32X3/8 THP SS	
31	P2-306960	1	BOX OUTLET MOD-100TDM AF	
31	2A-37544	1	CAPLUG MACH HW-106 7/8 DI	
33	2I-Z12311	4	GASKET-FIBER WASHER	
34	2K-34136X	2	FTG FLEX CON 90 X 1/2 MOD	
35	P2-WL0668	1	POT ASSY W DRAIN	SS10
	P2-WL0659			SS8
36	P2-WL0689	1	ASM-ELEM MTG-SS8 DEEPER	SS8
	P2-WL0690		ASM-ELEM MTG-SS10 DEEPER	SS10
37	P2-Z19027	1	CLAMP-T-BULB-SS8,10I DP	
38	P2-WL0683	1	ASM-COVER INSUL SIDE	SS10
	P2-WL0660			SS8
NI	2C-46591	2	CLAMP HOSE 5/8	
NI	2K-31040	AR	BUSHING HEYCO 7/8 OD	
NI	P2-Z17898	1	CORDSET-14/3, 6-15P, #8GRD	SS8TDUCIAF, SS10TDUCIAF
NI	P2-Z17897	1	CORDSET-14/3, 5-15P, #8GRD	SS8TDUCIAF12, SS10TDUCIA12

M011D.01 2M-Z17558 Owners Manual for Built-In Round T'Stat Warmers



## PARTS & SERVICE

### DESCRIPTION

ADAPTER TOP, convert SS8 to hold 4 qt. inset  
 ADAPTER TOP, convert SS10 to hold 4 qt. inset  
 ADAPTER TOP, convert SS10 to hold 7 qt. inset  
 2½ QT. ROUND INSET w/ lid  
 4 QT. ROUND INSET w/ lid  
 7 QT. ROUND INSET w/ lid  
 11 QT. ROUND INSET w/ lid  
 11 QT. ROUND INSET w/ hinged lid

### PART NO.

WS-20177  
 WS-20822  
 WS-20175  
 NLA  
 WS-20774  
 WS-20587  
 WS-20908  
 WS-21057

**IMPORTANT:** Use only factory authorized service parts and replacement filters.

For factory authorized service, or to order factory authorized replacement parts, contact your Wells authorized service agency, or call:

### ACCESSORIES

8 oz. SOUP LADLE

2L-47567

### Wells

10 Sunnen Dr.,  
 St. Louis MO 63143 USA

WELLSLOK EXTENSION KIT, for UL LISTED circular warmers only, adapt to wood counter up to 1¾" thick

WS-22592\*

Service Dept.  
 phone: (800) 264-7827

\* Wellslok Extension Kits for UL Listed units approved for installation in wood counter tops One well units require one kit / Two and three well units require two kits / four and five well units require three kits

Service Parts Department can supply you with the name and telephone number of the WELLS AUTHORIZED SERVICE AGENCY nearest you.

DRAIN VALVE EXTENSION KIT, extension from drain to counter front with remote handle, for use with "D" models only, excluding "DM" models

WS-20385

DRAIN SCREEN

2V-Z17446

OPTIONAL 72" WIRING, thermostatically controlled warmers\*\*

\*\* contact factory customer service for availability

### CUSTOMER SERVICE DATA

please have this information available if calling for service

RESTAURANT \_\_\_\_\_ LOCATION \_\_\_\_\_

INSTALLATION DATE \_\_\_\_\_ TECHNICIAN \_\_\_\_\_

SERVICE COMPANY \_\_\_\_\_

ADDRESS \_\_\_\_\_ STATE \_\_\_\_\_ ZIP \_\_\_\_\_

TELEPHONE NUMBER (\_\_\_\_) \_\_\_\_\_ - \_\_\_\_\_

EQUIPMENT MODEL NO. \_\_\_\_\_

EQUIPMENT SERIAL NO. \_\_\_\_\_

VOLTAGE:(checkone)  120  208  240



Wells proudly supports CFESA  
Commercial Food Equipment Service Association

**SERVICE TRAINING - QUALITY SERVICE**



**CUSTOMER SATISFACTION**



**WELLS MANUFACTURING**

265 Hobson Street, Smithville, Tennessee 37166

telephone: 800-264-7827

[www.wells-mfg.com](http://www.wells-mfg.com)