



Exacting Standards, Just Like yours, since 1948

Project _____

Item Number _____

Quantity _____

1000S



1000S Premium Series Automatic Slicer

□ 1000S: 1/2HP Premium series slicer



Certified by NSF International to Meet and Exceed the NSF/ANSI 2010 standards

Automatic slice control with 3 speeds, 3 stroke lengths, and a slice counter.

13" Precision slicing German hollow ground blade
Ultra safe zero blade edge exposure while cleaning
Unique smooth curve transitions to redirect liquids away from controls and operator

Features:

- Supermarket quality slicer
- Simple to use automatic slice control with 3 speeds, 3 stroke lengths, and a slice counter.
- 13" Precision slicing German hollow ground blade
- Unique drip tray fence redirects liquids away from controls and operator towards distinctive concaved base casting for easy cleaning
- Powerful 1/2 hp motor standard
- Ergonomic comfort design operation
- Ultra safe zero blade edge exposure while cleaning
- Adjustable slice thickness from 0 to 7/8"
- Capable of slicing high volume amounts of cheese
- Hygienic remote sharpener
- Quick and simple disassembly of carriage and feed grip for easy and thorough cleaning
- Sanitary polished & anodized aluminum construction
- Heavy duty 3-1/2 lb gravity feed grip

- Permanently mounted protective edge guard
- Built-in lift lever for under slicer cleaning
- Stationary knife guard and carriage knobs can't be lost or misplaced
- Carriage tilts out to simplify cleaning

Optional Accessories:

- Stainless Steel Blade
- Heavy Duty Clear Plastic Cover
- Stainless Steel Vegetable Chute
- Sturdy Stainless Steel Stand
- Security Enforced Prison Package

Warranty:

- 1 year, on-site parts and labor

Premium Series Slicer

Univex Corporation

Warranty Details

The 1000S carries a 1 year, on-site parts and labor warranty against any flaws in materials and workmanship. This period begins on the date of the purchase and, provided the unit is used in accordance with our instructions, is in full effect for 1 year from that date. Any work performed under this warranty must be performed between the hours of 8am and 5pm Monday through Friday. Univex will not pay for overtime charges for work performed other than during normal business hours. Damage incurred in transit or from installation error, accident, alteration or misuse is not covered. Univex shall not be liable for any consequential compensatory, incidental, or special damages. Contact the Univex service department for any warranty claims.



Univex Corporation
www.Univexcorp.com

3 Old Rockingham Rd
Salem, NH 03079
United States of America

Telephone (800) 258-6358
Intl Tel. (603) 8936191
Fax (800) 356-5614
Intl Fax (603) 8931249



Exacting Standards, Just Like yours, since 1948

1000S Premium Slicer

1000S

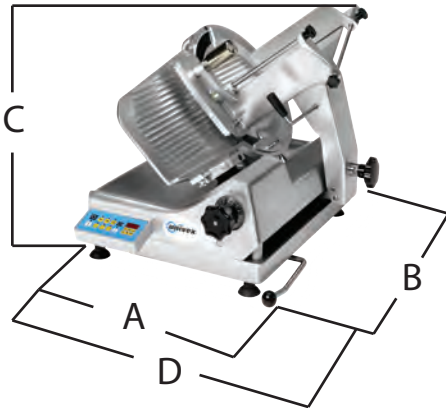

- A:** Width
24" (60.96cm)
- B:** Depth
28.5" (72.39cm)
- C:** Height
21.5" (54.61cm)
- D:** Width w/ Carriage Tilted
31" (78.74cm)

Auto or Manual	Motor	Volts	Hz	Amps	Drive Type	Blade RPM	Cheese slicing	Blade Diameter	Max Slice	Product Cutting Capacity		
										Rec (Rectangle)	S (Square)	R (Round)
Manual/Automatic	1680 RPM 1/2 HP (.37kW)	115V 220V	60 50-60	4amp 2.5amp	Belt Driven	337	High Volume	13" (33cm)	.875" (22.2mm)	10.25" x 6" (26cm x 15.2cm)	6" x 6" (15.2cm x 15.2cm)	8" (20.3cm)

Carriage stroke:

small	medium	Large	Manual
4.25" (10.8cm)	7.5" (19cm)	11" (28cm)	11.75" (29.8cm)

Carriage strokes per minute:

	small	medium	Large
Slow	51	39	35
Medium	59	44	42
Fast	64	50	52

Controls: Manual slice thickness knob, Digital membrane control for speed, stroke, and counter, and removable blade sharpener.

NSF International certified ANSI/ NSF 8

This slicer is certified by NSF International to meet and exceed the NSF 8 standard. Here is a list of highlighted features that are standard on our entire ANSI/ NSF8 certified slicer line:

- Improved liquid and food particle diversion from all control surfaces
- Improved seals and gaskets for longer life and greater sanitary standards
- Clear and easy to follow cleaning and sanitizing instructions

Shipping Information:

Freight Class: 85
 Net Weight: 115.6 lbs (52.4kg)
 Shipping Weight: 125lbs (56.9kg)

Shipping Box Dimensions:

Height: 29.1" (740mm)
 Width: 25.4" (645mm)
 Length: 29.5" (750mm)



2010



Univex Corporation
www.Univexcorp.com

3 Old Rockingham Rd
 Salem, NH 03079
 United States of America

Telephone (800) 258-6358
 Intl Tel. (603) 8936191
 Fax (800) 356-5614
 Intl Fax (603) 8931249