



SaniServ[®]
An AFFINIS GROUP Company

Item No. _____
Quantity _____
Job Name _____

Designed For Medium Volume Applications
8 Gallons per Hour – 26-Quart Capacity
High Frozen Product Visibility Means High Profits!

Model 108
Countertop
Frozen Beverage Machine

The **SaniServ** Model 108 Frozen Beverage Machine provides owners and operators everything they are asking for: Frozen beverage visibility merchandising in a consistent and reliable machine! The 108's extra large 8 inch faceplate design allows customers to view colorful frozen beverages being offered without the condensation and unreliable operation of traditional "bubble top" machines! The high frozen product visibility, along with increased production and reliability, results in increased sales and high profits!

Space Saving

Small Footprint Design - **SaniServ** model 108 offers frozen product visibility in reliable space saving equipment and design! Owners and Operators can turn the countertop into a highly colorful profit center by providing the frozen beverages customers enjoy!

Easy Cleaning and Operation

Fewer Parts = Simplified Cleaning – **SaniServ** equipment is designed and built with the fewer parts to be disassembled, cleaned and sanitized than any other machine in the industry.

High Return on Investment

Increased Profits – **SaniServ** machines combine affordable efficiency with consistent product quality and fast quiet operation to insure customer satisfaction with high profit frozen beverages.

Quality Design

Durability – **SaniServ** machines are built to achieve long and dependable life through simplicity of design. Every machine is shipped standard with a stainless steel exterior, durable steel interior frame construction, heavy-duty components and consistency systems.



Made in the USA

SaniServ Model 108

Counter Model Frozen Beverage/Cocktail Freezer

For sales information contact:

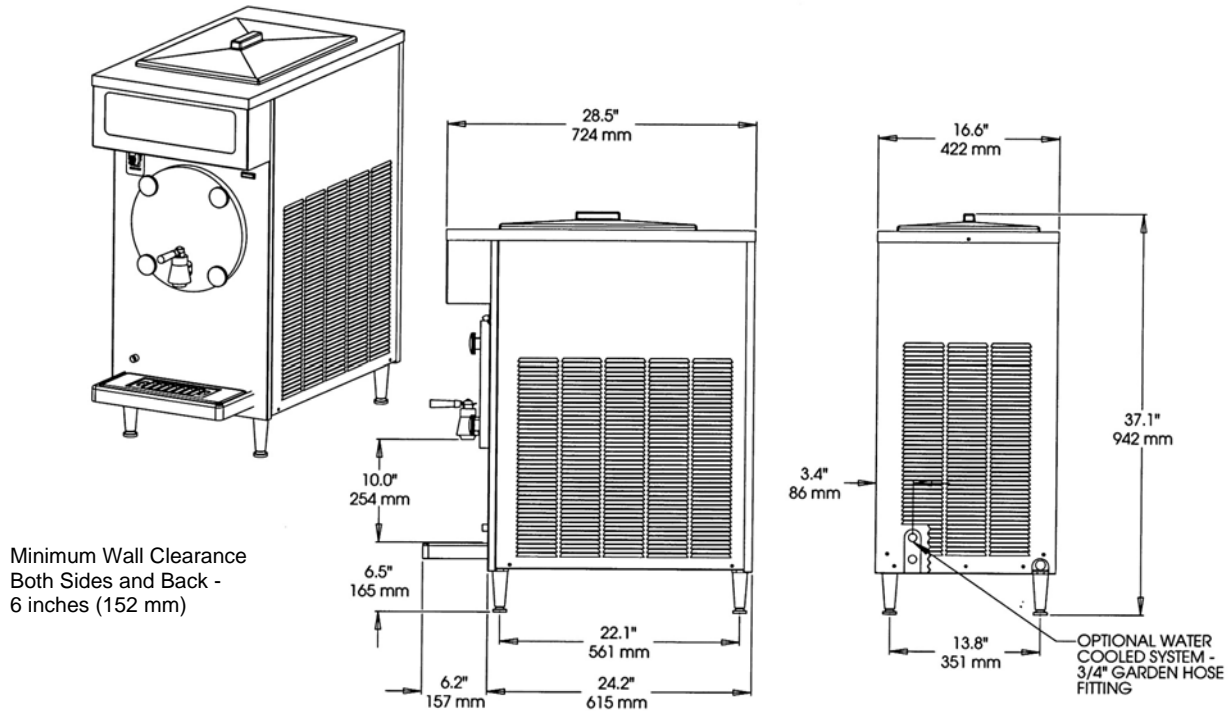

Minimum Wall Clearance
Both Sides and Back -
6 inches (152 mm)

ELECTRICAL				WIDTH	HEIGHT	DEPTH	WEIGHT	VOLUME
VOLTS	Hz	Ph.	Amps	INCHES (mm)	INCHES (mm)	INCHES (mm)	LBS. (Kg)	CU FT. (cu. m.)
115	60	1	15	16.6 (422)	37.1 (942)	28.5 (724)	210 (95)	
Shipping Specifications				22.5 (572)	36.5 (965)	36.5 (927)	250 (114)	18 (.51)

Specifications:

Cooling System: Air or Water

Dasher and Compressor Motors:
1/4 HP Dasher 3/4 HP Compressor

Refrigerant Type: R404A

Listings: UL, cUL, NSF

Features:

Evaporator and Mix Reservoir Capacity: 26 Quarts (24.6 liters)

Dasher: Heavy-Duty Stainless Steel with low friction scraper blades.

Controls: Automatic consistency controls for improved product consistency.

Solid-state Automatic Visual Mix Out Alert System

Warranty:

Parts	1 year
Compressor	5 years
Evaporator	5 years

Options:

- Tune Up Kit
- Parts Tray
- Drink Spinner
- Counter Top Mounting Pad
- Machine Stand
- Wash Out Kit - 3/8" Flare Fitting
- Water Cooled - 3/4" Garden Hose Fitting
- Export Voltage

We reserve the right to change specifications and product design without notice. Such revisions do not entitle the buyer to corresponding changes, improvements, additions or replacements for previously purchased equipment.

SaniServ®

P.O. Box 1089
451 East County Line Road
Mooresville, IN 46158
Ph: 317 831-7030 Fax: 317-831-7036
www.SaniServ.com



Made in the USA

Rev. 2/06