



PALLADIO 330 AUTOMECH W 13"

Automatic slicer, variable speed



Palladio 330 AUTOMECH

- Automatic slicer designed for repeatable slicing requiring limited attendance, maximizing the productivity of kitchen labor. Manual mode included
- Convenient 10-speed dial control
- Special end weight and adjustable vertical product fence to provide stability and advance products evenly
- Carriage release system for manual operation
- Exclusive high-quality, rounded, no edges design, increased blade and machine body gap, easy breakdown for a fast and effective cleaning
- Inner blade cover ensures a perfectly aligned cut. No waste when cutting same product at different times.
- Zero blade exposure due to a permanent blade rim guard, a safety hand guard mounted to the carriage and a carriage lockout to prevent exposed blade edge
- No voltage release prevents inadvertent reactivation after a power outage

Features

Technical:

- The sharpener assembly is made entirely from aluminum, no plastic presence that may break with heavy use.
- The tie rod assembly and all external screws are made of stainless steel for longer life.
- The slide shaft is made of ground, chromed steel for a smoother operation.
- The high-quality bushings and ball bearings are self-lubricating.
- The dial thickness control cam system allows for an always precise cut.

Safety:

- A safety cover is placed under the motor and the electrical components.
- The carriage features an exclusive heavy duty plastic protection to keep operator's hand at a safe distance from the blade while operating the slicer.
- A permanently-mounted knife ring guard covers the non-cutting side of the blade.
- Overload and no volt release protection

Sanitary:

- Easy to clean aluminum alloy construction does not crack or stain.
- The screws are stainless steel and resist wear and oxidation.
- The carriage and the center plate are quickly removable without tools.

Optional

- Vegetable Chute.

Specifications

Operation:

Automatic and manual modes. Gravity feed design.

Construction:

Polished, anodized aluminum alloy.

Knife:

One piece, chromium plated 100Cr6 forged carbon steel blade.

Sharpener:

Built-in, removable, two stone dual action.

Slice thickness:

Infinitely variable up to 1"

Slices per minute:

From 5 min. to 60 max. Variable speed.

Cutting capacity:

10 5/8" wide x 8 1/4" high rectangle. 9 1/2" diameter round.

Motor:

0.55 Hp (410 W), fan cooled.

Electrical:

120V AC, 60Hz, 3.4A.

Plug & Cord:

Attached, flexible, 3 wire SJT 18 AWG, 6'4" long cord.

Blade controls:

ON/OFF s/steel keypad. IP 67 waterproof. No voltage release

Carriage controls:

ON/OFF s/steel keypad. IP 67 waterproof. No voltage release. 10-speed dial control.



Certified to UL Standard 763 and NSF Standard 08
 Certified to CSA Standard C22.2



Inner blade cover avoids product waste



Large receiving tray



Wide gap between blade and body



Vegetable Chute option

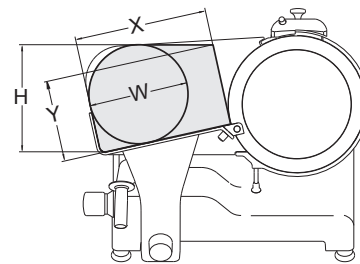
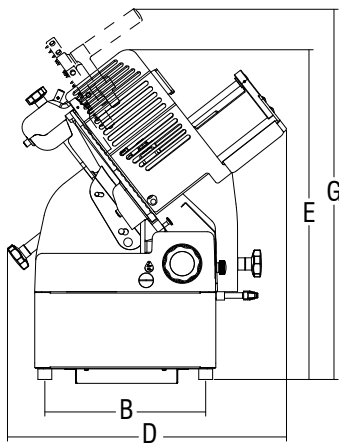
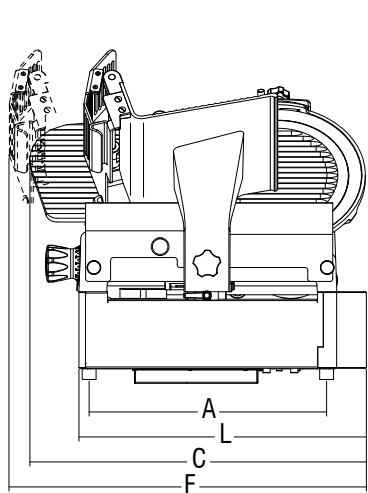

	Ø Blade	Motor	Cut thickness	Blade rpm	Carriage stroke	Hopper	A	B	C	D	E	F	G	X	Y	H	W	Net weight	Shipping	Gross weight
	mm/inch	watt/Hp	inch.	rpm	inch.	inch.	inch.	inch.	inch.	inch.	inch.	inch.	inch.	inch.	inch.	inch.	inch.	lbs.	inch.	lbs.
Palladio 330 AUTOMECC VV	330/13"	410-0.55	1"	315	12 3/16"	14 3/8" x 10 5/8"	18 5/16"	13 3/8"	26 15/16"	26	26 3/8"	27 9/16"	29 1/2"	9 7/16" / 9 7/16"	8 1/4"	10 1/4"	9 7/16"	123	34 1/4" x 33 1/16" x 33 1/2"	165



SIRMAN USA, Inc. 9490 Franklin Avenue Franklin Park, IL 60131 U.S.A.
 Toll free: 866-643-6872

Phone: +1 847-288-9500
 Fax: +1 844-836-7076

sirmanusa@sirman.com
 www.sirman.com