



Standard Features

- Low water usage – 1.0 gallons per rack
- Total automatic cycle – 58 seconds
- Built-in pressure regulator and gauge
- Special designed stainless steel nozzles provide superior cleaning action
- 17 1/4" door opening accepts 18" trays
- Field convertible straight through to corner
- Interchangeable wash/rinse arms screw out for simple cleanup
- Heavy duty stainless steel construction
- Electromechanical controls
- Auto-fill
- Auto-start
- Safety door switch
- Delime/manual wash switch
- Low watt density electric wash tank heater
- Hi-limit thermostat and low water protection
- Top mounted controls for ease of installation
- Adjustable bullet feet
- Uses standard 20" x 20" racks
- Detergent/rinse additive signal connection fuse block
- Built-in booster heater sized to raise incoming 140°F water to 180°F for sanitizing rinse. No external booster heater is required.
- Optional 70°F rise booster heater is available with no additional cost (must be specified).

Power/Connections

Electrical Rating

Wash Pump Motor Horsepower		3/4
Electric Wash Tank Heater	Volts	KW
	208	4.1
	230	5.0
	460	5.0
40° rise Electric Rinse Booster	Volts	KW
	208	9
	230	11
	460	11
70° rise Electric Rinse Booster	Volts	KW
	208	10.5
	230	12.9
	460	12.9

Steam Requirements

Steam Flow Pressure (PSIG)	15-20
Consumption at 15 PSIG (lbs/hr)	45

Water Requirements

Inlet Temperature (°F)	
40°F Rise	140
70°F Rise	110
Gallons per Hour	52.2
Waterline Size IPS (Minimum) (Inches)	3/4
Drainline Size IPS (Minimum) (Inches)	1 1/2
Flow Pressure (PSI)	15-25

Models with the following electrical specifications are available without UL Listing: 230/50/1, 230/50/3, 380/50/3.

Performance/Capacities

Operating Capacity

Racks per Hour	57
Dishes per Hour	1425
Glasses per Hour	1425

Operating Cycle (Seconds)

Wash Time	45
Rinse Time	11
Dwell	2
Total Cycle	58

Tank Capacity (Gallons)

Wash Tank	8
Booster Tank	3

Pump Capacity (GPM)

Pump Capacity (GPM)	150
Operating Temperatures	
Wash – °F (Minimum)	150
Rinse – °F (Minimum)	180

Frame Dimensions (Inches)

Width	25 1/4
Depth	25 1/4
Height	64 3/8
Standard Table Height	34
Wall Clearance (Minimum)	4
Inside Clearance (Height)	17 1/4

Shipping Weight (Lbs.)

Shipping Weight (Lbs.)	350
------------------------	-----

Shipping Size (Inches)

Width	30
Depth	30
Height	72

Short Form Specifications

Item No. _____

Unit shall be Jackson Tempstar Upright door hot water sanitizing dishmachine.
 Electrical characteristics to be ___ volts / 60 cycles / ___ phase operation with a 58 second automatic cycle using 57 gallons of 180° F. final rinse water per hour.
 Stainless steel construction to include hood, frame, wash tank, and adjustable feet.
 A 3/4 HP motor mounted to a stainless steel pump with a stainless steel impeller shall be mounted to the machine frame. As standard the unit shall include:

- A 40° F. temperature rise booster heater mounted within the footprint of the machine.
- Single point connections for all utilities
- Top mounted control box with electro-mechanical components and a Delimiting switch as standard.
- Front dress Panel
- Door cycle switch
- Automatic fill
- Built-in water pressure regulator.
- Field convertible from straight through to corner operation.

Unit shall be NSF and UL Approved.

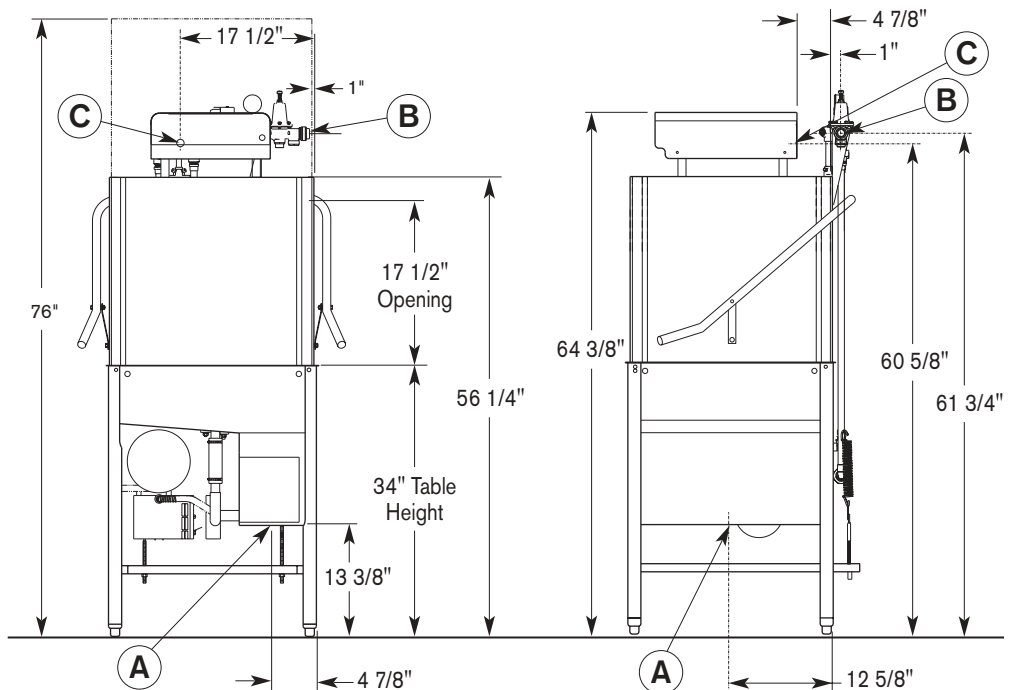
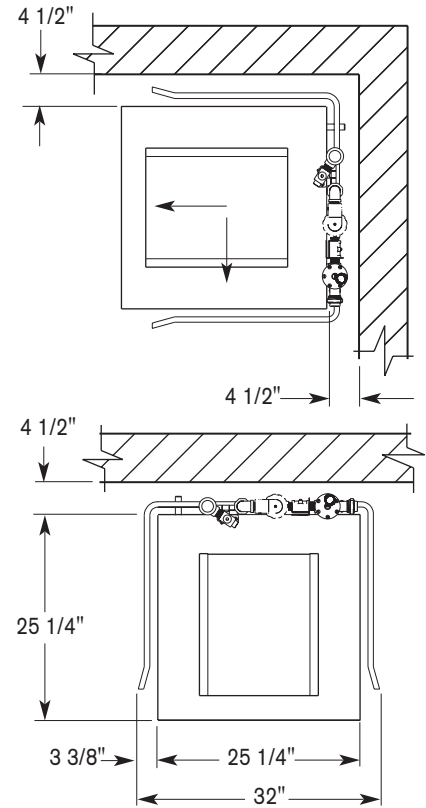

LEGEND:

- A – Drain 1 1/2" I.P.S.
- B – Water inlet 3/4" I.P.S
- C – Electrical connection.
(See table)

All dimensions in inches.
 All vertical dimensions are +/- 1/2" from floor due to adjustable bullet feet.

Approximate Total Load Amps

Power Supply	40° rise	70° rise
208/60/1	68.7	75.8
230/60/1	75.4	83.6
208/60/3	42.1	46.3
230/60/3	45.5	50.7
460/60/3	21.7	24.1



www.jacksonmsc.com
 1-888-800-5672

