

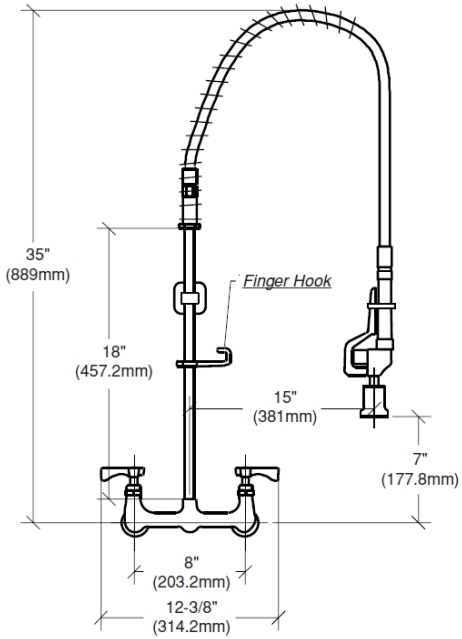

8" Center Wall Mount Pre-Rinse

Model: **17-108W**
 Project: _____
 Item #: _____
 Quantity: _____

Plumbing



Front View

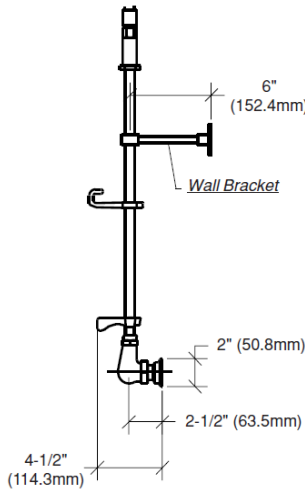

Side View

Parts Breakdown	
21-137	Wall Bracket
21-160	18" Riser
21-161	Spring Retainer
21-162	Spring
21-133	44" Hose Assembly
21-164	Grip
21-129	Spray Valve
21-165	Hook/Screw Assembly
21-170	Ring
21-108	8" Center Wall Mount Base

Standard Features

- 1/4 turn high performance ceramic cartridge valves with built-in back flow preventers
- Heavy duty flanges with eccentric fittings for quick installations
- Mounting kit included (1/2" NPT x 1 1/2" male nipples with locknuts)
- Pre-assembled at factory to cut installation time
- 44" heavy duty stainless steel clad flexible hose. Tested to 400 psi
- Wall bracket included
- Full replacement parts available
- 1 year warranty

Specifications

- 8" on center wall mount with 1/2" NPT female inlets
- Rough in: Two 7/8" round holes on 8" centers
- Water saver spray head, 1 1/2 gpm @ 60 psi flow rate complies with EPA Act 2005
- 3/8" NPT x 18" riser pipe with hook. Pre-assembled to base at factory
- Temperature range: 40°F to 180°F
- Shipping weight: 13 lbs.
- Quantity per case: 3



Approved By: _____

Due to our commitment to continued product improvement, specifications are subject to change without notice.

Krowne Metal Corporation
 100 Haul Road, Wayne, New Jersey 07470
 www.krowne.com sales@krowne.com

Phone: 800-631-0442
Fax: 973-872-1129



8" Center Wall Mount Pre-Rinse Low Lead Compliant



Model: **17-108WL**

Project: _____

Item #: _____

Quantity: _____

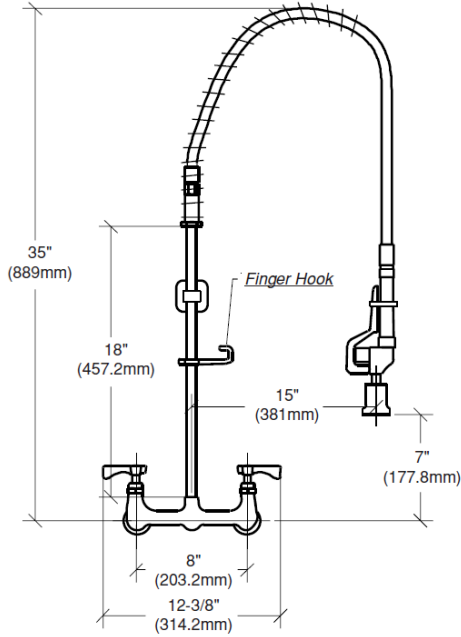

Front View

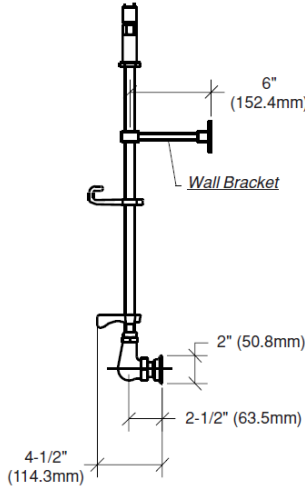

Side View

Parts Breakdown	
21-137	Wall Bracket
21-160L	18" Riser
21-161	Spring Retainer
21-162	Spring
21-133L	44" Hose Assembly
21-164L	Grip
21-129L	Spray Valve
21-165	Hook/Screw Assembly
21-170	Ring
21-108L	8" Center Wall Mount Base

Plumbing

Standard Features

- 1/4 turn high performance ceramic cartridge valves with built-in back flow preventers
- Heavy duty flanges with eccentric fittings for quick installations
- Mounting kit included (1/2" NPT x 1 1/2" male nipples with locknuts)
- Pre-assembled at factory to cut installation time
- 44" heavy duty stainless steel clad flexible hose. Tested to 400 psi
- Wall bracket included
- Full replacement parts available
- 1 year warranty

Specifications

- Low Lead Compliant to meet California AB-1953 and Vermont S152 standards
- 8" on center wall mount with 1/2" NPT female inlets
- Rough in: Two 7/8" round holes on 8" centers
- Water saver spray head, 1 1/2 gpm @ 60 psi flow rate complies with EAct 2005
- 3/8" NPT x 18" riser pipe with hook. Pre-assembled to base at factory
- Temperature range: 40°F to 180°F
- Shipping weight: 13 lbs.
- Quantity per case: 3



Approved By: _____

Due to our commitment to continued product improvement, specifications are subject to change without notice.



100 Haul Road, Wayne, New Jersey 07470

www.krowne.com

sales@krowne.com

Phone: 800-631-0442

Fax: 973-872-1129