



Deck Mount Pre-Rinse

Model: 17-202W

Project: _____

Item #: _____

Quantity: _____

Plumbing

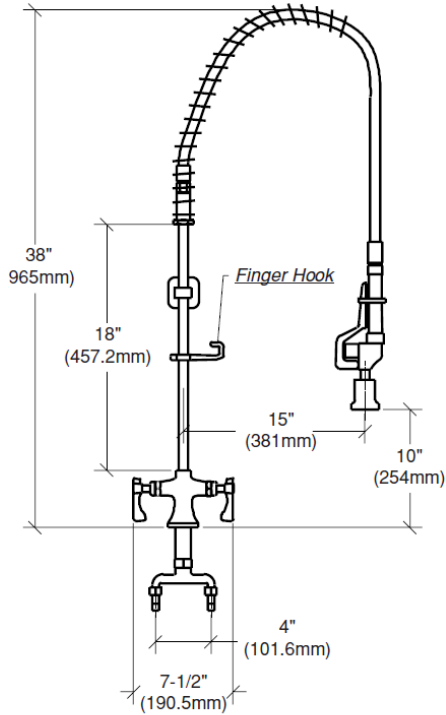

Front View

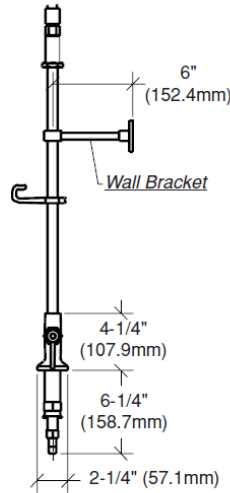

Side View

Parts Breakdown

21-137	Wall Bracket
21-160	18" Riser
21-161	Spring Retainer
21-162	Spring
21-133	44" Hose Assembly
21-164	Grip
21-129	Spray Valve
21-165	Hook/Screw Assembly
21-170	Ring
21-202	Deck Base

Standard Features

- 1/4 turn high performance ceramic cartridge valves with built-in back flow preventers
- Pre-assembled at factory to cut installation time
- 44" heavy duty stainless steel clad flexible hose. Tested to 400 psi
- Wall bracket included
- Full replacement parts available
- 1 year warranty
- Mounting kit included

Specifications

- Single hole deck mount, 1/2" NPT male inlets with 1/4"
- Rough in: Single 1 1/4" hole
- Water saver spray head, 1 1/2 gpm @ 60 psi flow rate complies with EPAAct 2005
- 3/8" NPT x 18" riser pipe with hook. Pre-assembled to base at factory
- Temperature range: 40°F to 180°F
- Shipping weight: 13 lbs.
- Quantity per case: 3



Approved By: _____

Due to our commitment to continued product improvement, specifications are subject to change without notice.



100 Haul Road, Wayne, New Jersey 07470

www.krowne.com

sales@krowne.com

Phone: 800-631-0442

Fax: 973-872-1129



Deck Mount Pre-Rinse Low Lead Compliant



Model: **17-202WL**

Project: _____

Item #: _____

Quantity: _____

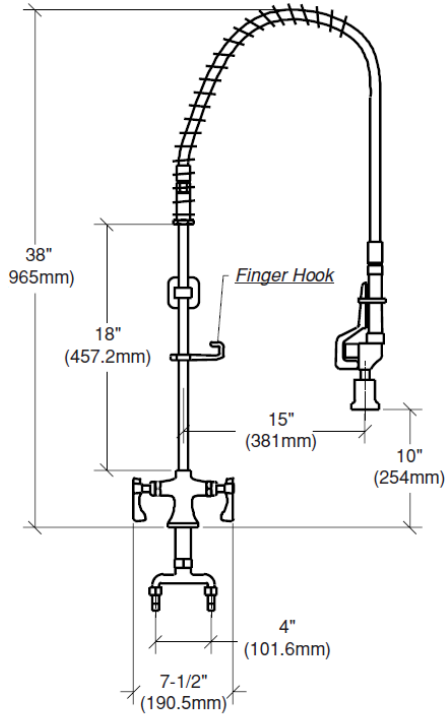

Front View

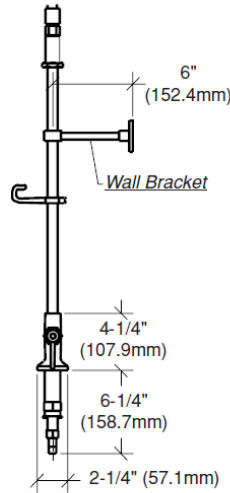

Side View

Parts Breakdown

21-137	Wall Bracket
21-160L	18" Riser
21-161	Spring Retainer
21-162	Spring
21-133L	44" Hose Assembly
21-164L	Grip
21-129L	Spray Valve
21-165	Hook/Screw Assembly
21-170	Ring
21-202	Deck Base

Standard Features

- 1/4 turn high performance ceramic cartridge valves with built-in back flow preventers
- Pre-assembled at factory to cut installation time
- 44" heavy duty stainless steel clad flexible hose. Tested to 400 psi
- Wall bracket included
- Full replacement parts available
- 1 year warranty
- Mounting kit included

Specifications

- Low Lead Compliant to meet California AB-1953 and Vermont S152 standards
- Single hole deck mount, 1/2" NPT male inlets with 1/4"
- Rough in: Single 1 1/4" hole
- Water saver spray head, 1 1/2 gpm @ 60 psi flow rate complies with EPA Act 2005
- 3/8" NPT x 18" riser pipe with hook. Pre-assembled to base at factory
- Temperature range: 40°F to 180°F
- Shipping weight: 13 lbs.
- Quantity per case: 3



Approved By: _____

Due to our commitment to continued product improvement, specifications are subject to change without notice.



100 Haul Road, Wayne, New Jersey 07470

www.krowne.com

sales@krowne.com

Phone: 800-631-0442

Fax: 973-872-1129