

Waste & Recycling Stations

Stainless Steel



Model 3415
(Shown in Light Maple finish.)

Attractive Functionality And Durability

Benefits

- Provide waste disposal and recycling in one unit
- Durable welded stainless steel construction is easy to clean

Features

- Various waste/recycle configurations
- Choice of stainless steel or laminate exterior finishes
- Liquid/cup waste models include drainage sink and 7-gallon liquid storage receptacle
- Leveling feet provide easy floor leveling



Model 4310



Model 3320 / 4312

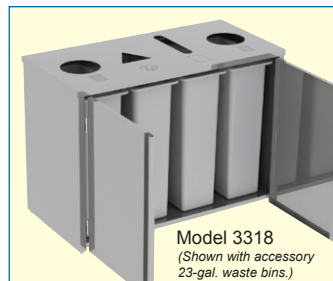

Model 3318
(Shown with accessory
23-gal. waste bins.)



Model 3320 Top



Optional Solid Surface Resin Top

Spec. # _____

AIA # _____

Specifications:

Unit shall be of welded stainless steel construction and shall have 20-gauge sides and 18-gauge top. Interior compartment floor shall be 18-gauge stainless steel. Units shall have specific chute openings to accept waste/refuse, recyclables (plastic bottles/aluminum cans), paper, or liquids. Chute openings shall have symbols indicating function. Liquid/Cup Refuse units shall feature a refuse chute and include a drop-in stainless steel drainage sink and sealed 7-gallon polyethylene liquid receptacle. Front-access models shall have a 4" high raised edge to accommodate tray storage. Units shall have leveling feet to prevent rocking on uneven floors. Hinged compartment door(s) shall have full-length finger grip and magnetic closure latch.

Waste & Recycling Stations

Stainless Steel

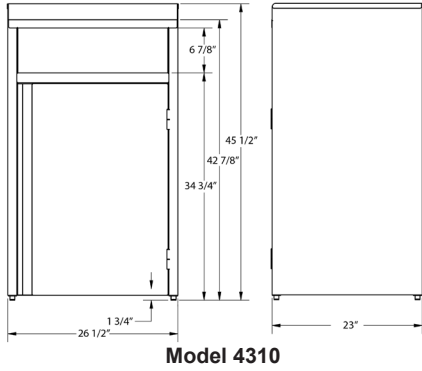

Model 4310



7-Gal. Liquid Receptacle (#3320, #3420)

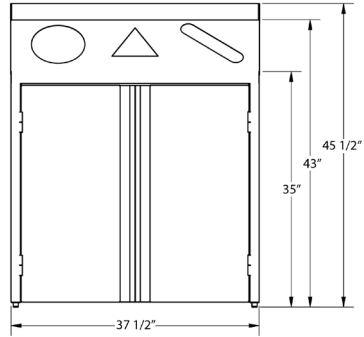
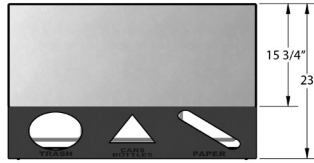

Model 4315

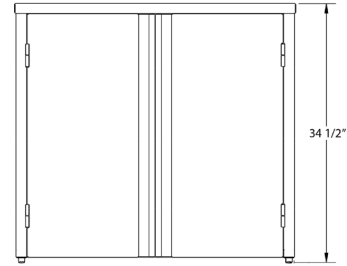
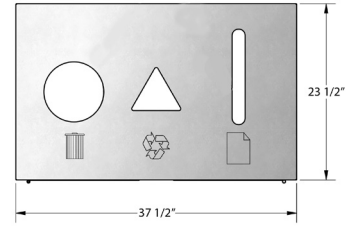

Model 3315

Product Information:

Model	Overall Size			Description	Exterior Finish	Case Wt. Lbs. (Kg)
	W	D	H			
<i>Top Access Style</i>						
3310	26½" (673)	23¼" (591)	34½" (876)	Refuse	Stainless Steel	61 (27.7)
3312	26½" (673)	23¼" (591)	34½" (876)	Refuse/Recycle	Stainless Steel	61 (27.7)
3315	37½" (953)	23¼" (591)	34½" (876)	Refuse/Recycle/Paper	Stainless Steel	84 (38.1)
3318	48½" (1232)	23¼" (591)	34½" (876)	Refuse (2)/Recycle/Paper	Stainless Steel	104 (46.3)
3320	26½" (673)	23¼" (591)	34½" (876)	Liquid/Cup Refuse	Stainless Steel	61 (27.7)
3410	26½" (673)	23¼" (591)	34½" (876)	Refuse	Laminate	65 (29.5)
3412	26½" (673)	23¼" (591)	34½" (876)	Refuse/Recycle	Laminate	65 (29.5)
3415	37½" (953)	23¼" (591)	34½" (876)	Refuse/Recycle/Paper	Laminate	88 (39.9)
3418	48½" (1232)	23¼" (591)	34½" (876)	Refuse (2)/Recycle/Paper	Laminate	106 (48.1)
3420	26½" (673)	23¼" (591)	34½" (876)	Liquid/Cup Refuse	Laminate	65 (29.5)
<i>Front Access Style</i>						
4310	26½" (673)	23¼" (591)	45½" (1156)	Refuse	Stainless Steel	75 (34)
4312	26½" (673)	23¼" (591)	45½" (1156)	Refuse/Recycle	Stainless Steel	75 (34)
4315	37½" (953)	23¼" (591)	45½" (1156)	Refuse/Recycle/Paper	Stainless Steel	91 (41.3)
4410	26½" (673)	23¼" (591)	45½" (1156)	Refuse	Laminate	80 (36.3)
4412	26½" (673)	23¼" (591)	45½" (1156)	Refuse/Recycle	Laminate	80 (36.3)
4415	37½" (953)	23¼" (591)	45½" (1156)	Refuse/Recycle/Paper	Laminate	95 (43.1)

Dimensions in () denote metric millimeters, unless otherwise noted.

Available Laminate Finishes

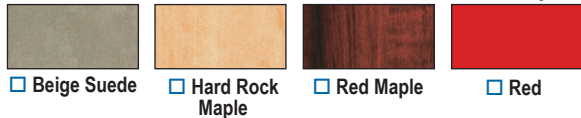

Options:

- 4" high industrial legs (increases O.A. height 3")
- Solid surface resin top

Accessories:

- 23-gal. poly waste bin (20" x 11" x 30") _____
- 35-gal. poly waste bin (20" x 20" x 27") _____



Lakeside Manufacturing, Inc.
4900 West Electric Avenue • West Milwaukee, WI 53219 U.S.A.
800-558-8565 • 414-902-6400 • Fax 414-902-6446 • www.eLakeside.com

Spec. #

AIA #