

D**3500 CONVECTION STEAMER
DIRECT STEAM ON 36" BASE**JOB NAME: _____
ITEM NO.: _____
NO. REQUIRED: _____**MODEL:** 3500M36D**SIZE:** 36" Wide x 33" Front-to-Back
(914mm Wide x 838mm Front-to-Back)**DESCRIPTION:**

Market Forge Model 3500M36D direct connect convection steam cooker. Will be integrally mounted on a cabinet base containing direct steam connections.

The 3500 will be of double-wall construction with 1" (25mm) thick insulation between cooking compartments and exterior walls, and will have two 18 gauge stainless steel welded cooking compartments with coved internal corners, and a 16 gauge stainless steel front panel.

Each cooking compartment on the 3500 has a positive slam action, field-reversible door constructed of Type 304 stainless steel. Door latches are spring loaded. The inner door gasket is a one-piece NSF-approved silicone rubber gasket. The cooking compartment is equipped with a door interlock (*switch*) that shuts off steam to the cooking compartment when the door is opened. Factory installs units with door opening from the right, see diagram.

Each compartment will be equipped with a perforated steam inlet baffle positioned for precise application of high velocity steam across the surface of food. Controls for each compartment will include a 60-minute load compensating timer with constant steam position, an indicator light, steam inlet solenoid valve, pressure relief valve, vacuum breaker, and an automatic cold water steam condenser system, and a removable drip trough.

Each compartment will be independently and automatically controlled by setting the cooking time on the 60-minute timer. At the end of cooking time, indicator light will turn off and a continuous signal will sound. Signal is silenced by returning the timer to the OFF position.

Stainless steel cabinet base will match other Market Forge stainless steel equipment. A stainless steel frame will be equipped with 6" (152mm) stainless steel legs and adjustable bullet feet, reinforced stainless steel counter-top, and stainless steel lift-off front cover. A cold water condenser will automatically condense all exhausted steam into water before it is released from the cooker.

COOKING CAPACITIES:

Each compartment will accommodate the following:

- (6) 12" x 20" x 1" deep pans
- (3) 12" x 20" x 2 1/2" deep pans
- (2) 12" x 20" x 4" deep pans

OPERATION WILL BE BY:

Direct steam at a minimum of 15 PSI (1 kg/cm²). Unit will be equipped with ball float trap to remove condensate from incoming steam line and a 3/4" (19mm) IPS pressure reducing valve which will reduce initial pressure of 20 to 50 PSI (1.3 to 3.5 kg/cm²) to required 15 PSI (1 kg/cm²) operating pressure. Minimum BHP required: 3.0 BHP.

OPTIONAL AT EXTRA COST:

- 12" x 20" x 1" Perforated Stainless Steel Pans.
- 12" x 20" x 2 1/2" Perforated Stainless Steel Pans.
- 12" x 20" x 2 1/2" Solid Stainless Steel Pans.
- 12" x 20" x 4" Perforated Stainless Steel Pans.
- 12" x 20" x 4" Solid Stainless Steel Pans.
- Digital Countdown Timer.
- Steam Take Off Kit.

The manufacturer reserves the right to modify materials and specifications without notice.

SPEC SHEET: S-4850C
07/09FOOD SERVICE EQUIPMENT
3500 Steam Cooker

PRINTED IN U. S. A.

**MARKET FORGE**
INDUSTRIES INC.35 Garvey Street • Everett • MA • 02149
Tel: (617) 387-47100 • Toll Free: (866) 698-3188 • Fax: (617) 387-4456 • Outside MA Fax: (800) 227-2659
E-Mail: custserv@mfi.com • Website: www.mfi.com

A City Discount

D**3500 CONVECTION STEAMER
DIRECT STEAM ON 36" BASE**

DETAILS & DIMENSION

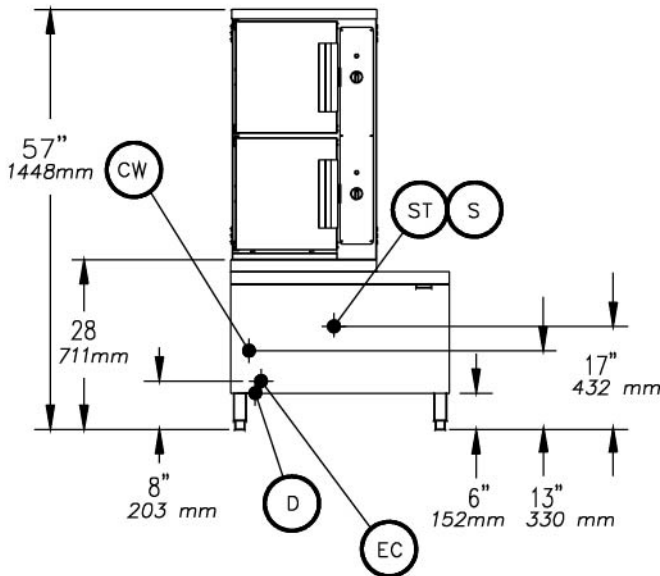
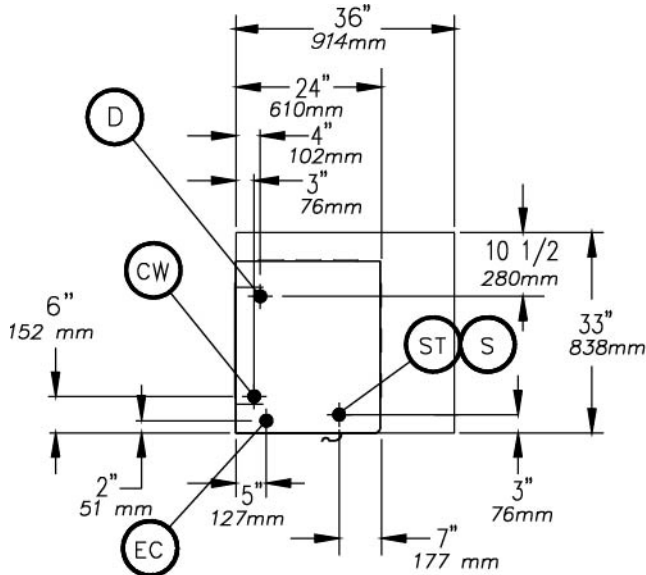
SPEC SHEET: S-4850C
07/09**FOOD SERVICE EQUIPMENT**
3500 Steam Cooker**SERVICE CONNECTIONS****Direct Connected:**

EC	Electrical Connection - 120 VAC, 60 Hz, 1/2" (13mm) conduit connection or equivalent. Use wire suitable for at least 90°C. Amp draw for cooker and boiler controls: 6 amps
CW	Cold Water - 3/8" (10mm) NPT for cold water to condenser. Cold water lines will have a maximum of 50 PSI (3.5kg/cw ²) and a minimum of 25 PSI (1.8 kg/cw ²) water pressure.
D	Drain - Pipe full 2" (50mm) I.P.S. to flush floor drain capable of receiving water flowing at a maximum rate of 5 gallons (19 liters) per minute. DO NOT MAKE SOLID CONNECTION TO FLOOR DRAIN. DO NOT INSTALL ELBOWS IN DRAIN LINE.
S	Steam Supply-Minimum BHP required: 3.0 BHP at a minimum pressure of 15 PSI (1.0 kg/cm ²). 3/4" (19mm) IPS pressure reducing valve will reduce incoming pressure of 20 to 50 PSI (1.3 to 3.5 kg/cm ²) to required 15 PSI (1.0 kg/cm ²).
ST	Steam Take-off - Connection for operations of adjacent steam powered equipment. Requires steam take-off kit (optional at extra cost).

NOTES: The only available space to supply utilities to the generator is a 6" (152mm) height between the floor and the cabinet.

PVC & CPVC are not acceptable materials for drain lines.

CAUTION: Before connecting water to this unit, water supply should be analyzed to make sure hardness is no greater than 2.0 grains per gallon and pH level is within the range of 7.0-8.5. Water which falls to meet these standards should be treated by installation of a water conditioner. **EQUIPMENT FAILURE CAUSED BY INADEQUATE WATER QUALITY IS NOT COVERED UNDER WARRANTY.**

It is our policy to build equipment which is design certified by U.L., A.S.M.E, N.S.F. and C.S.A. However, a continuing program of product improvement makes it necessary to submit new models to the agencies as they are developed and consequently not all models bear the appropriate agency labels at all times.



MARKET FORGE
INDUSTRIES INC.

35 Garvey Street • Everett • MA • 02149
Tel: (617) 387-47100 • Toll Free: (866) 698-3188 • Fax: (617) 387-4456 • Outside MA Fax: (800) 227-2659
E-Mail: custserv@mfi.com • Website: www.mfi.com

A City Discount