

Project Name: _____ AIA#: _____

Model #: _____ Location: _____

SIS#: _____ Item #: _____ Quantity: _____



Made in the U.S.A.



Precise slicing all day!
Hardened steel alloy knife and powerful continuous use motor.



Standard Features

Food Zone

- Large stainless steel radii, open space base design for cleaning and simple dismantling of components
- Knife sharpening system is removable and BPA Free (no-bisphenol-A), immersible, and dishmachine-safe for cleaning and sanitizing
- Moisture proof, easy-to-clean direct contact start/stop touchpad controls
- Sealed splash zones for added sanitation and protection of electronics



Premium Heavy-Duty Automatic Frozen Meat Slicer

Model 3975NF — 9 speed

Standard Features

Premium Construction

- 13" *PreciseEdge™* hardened steel alloy knife blade with maximum tip-edge-holding ability
- Stainless steel construction with superior corrosion resistance against acids found in fruit, meats and vegetables
- Best of the Best, *EZ-Glide™* slice system
- No-drip base with Marine edge — 1/2" to 3/4" wide and indented areas with 3/16" deep radiused transition and 3/16" deep internal coved corners — redirects liquid to center of base away from controls and operator
- 2° angled drip groove on slicer table directs liquid flow to base
- Precise slice-thickness adjustment, one-piece handle, gear driven and gasket-sealed
- Carriage angle: 45°, full gravity feed
- 12" long chute with 3 lb. stainless steel end weight
- Powerful 1/2 HP, 7 amp continuous use motor
- High-performance gear knife drive
- Maintenance-free drive system
- No voltage release prevents inadvertent reactivation of slicer in the event of power or interlock interruption
- Permanently attached knife blade ring guard with removable cover and deflector
- Knife cover interlock prevents slicer from operating without the knife cover in place
- Knife sharpening system is removable and BPA Free (no-bisphenol-A), immersible, and dishmachine-safe for cleaning and sanitizing
- Touch pad start/stop controls, power indicator light
- Ergonomic low-profile design reduces operator fatigue
- Dual arm lift lever for cleaning and sanitizing under slicer

Warranty

- **15-years on knife drive gears**
- **Two-years parts and one-year labor**

Warranty valid in North America, contact factory regarding warranty in other countries

Factory options and accessories:

To select factory installed options and accessories see back

Approved by: _____ Date: _____

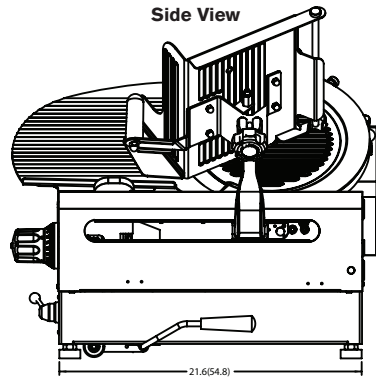
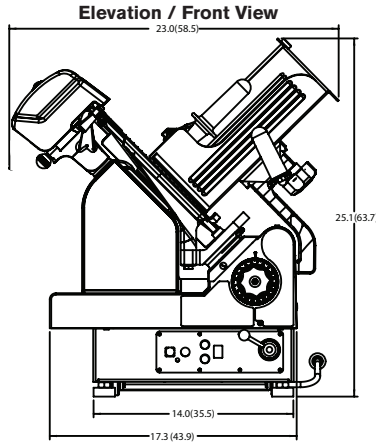

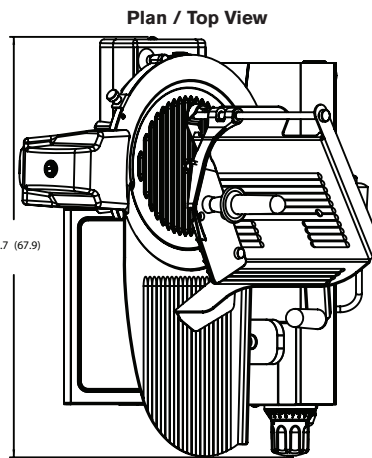
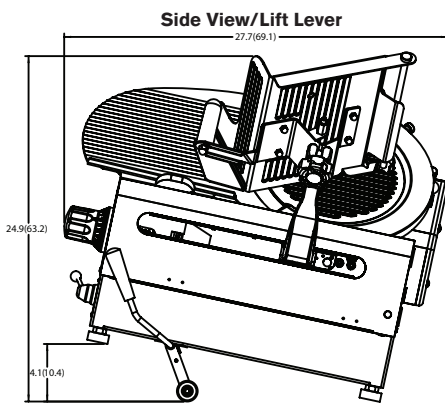

Note: different chute options will change overall height



Drawings available through KCL. www.kclcad.com

SPECIFICATIONS

Model	Auto or Manual	Motor	Volts	Amps	Drive Type	Slicing Volume per Day	Cheese Slicing	Blade Diameter	Max Slice	Product Cutting Capacity		
										D (Diameter)	W (Width)	H (Height)
3975NF	Both	1/2 HP	115-60-1	7	Gear	All Day		13" (33.02 cm)	1-1/4" (3.18 cm)	7.5" (19.50 cm)	11.6" (29.46 cm)	9" (22.86 cm)

Cord & Plug: Attached 7 foot flexible 3-wire cord with molded plug fits a grounded receptacle. NEMA 5-15 

DIMENSIONS | SHIPPING INFORMATION

Reinforced carton for shipping. The weight and dimensions of this reinforced carton are included below and may vary from shipment to shipment. **Shipped on a pallet. Freight class 77.5.**

Model	Foot Print	Overall Dimensions	Net Weight	Shipping Dimensions	Shipping Weight
3975NF	21.6" W x 14" D (35.5 cm x 54.8 cm)	23" W x 26.7" D x 25.1" H (69.7 cm x 58.5 cm x 63.7 cm)	145 lbs. (67.1 kg)	25" W x 28" L x 34" H (71.1 cm x 63.5 cm x 86.4 cm)	172 lbs. (78 kg)

FACTORY INSTALLED OPTIONS:

- QUICK-CLEAN™** Proprietary non-stick nickel-based coating (knife cover and slicer table)
- CORR** Correctional package
- MEATROOM** High moisture application package (includes 13" stainless steel knife)
- LONGCHUTE** 15" long food chute

OPTIONAL ACCESSORIES:

- 1047** Stainless steel low food fence (12" L x 1 3/8" H)
- 1326** Stainless steel high food fence (12" L x 3" H)
- 699-BAS** Stainless steel vegetable hopper (14" L x 7" D)
- SC-LARGE** Clear plastic slicer cover (recommended for preconstruction)
- CB** Additional cleaning brush