

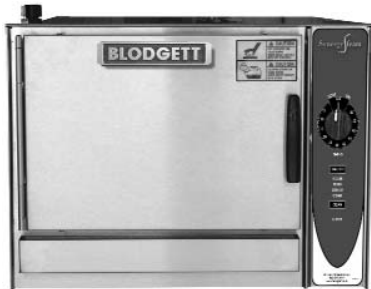

Synergy Steam

E-SN

Tabletop Electric Convection Steamer



3E-SN



5E-SN

OPTIONS AND ACCESSORIES

(AT ADDITIONAL CHARGE)

- Water Treatment System
- Stacking kit
- Stainless steel support stand
- Pan racks for support stand
- Single water connection (cold water)
- 4" adjustable legs



Project _____

Item No. _____

Quantity _____

- Model 3E-SN (3 pan electric tabletop convection steamer)
- Model 5E-SN (5 pan electric tabletop convection steamer)

CONSTRUCTION

- Stainless steel construction
- Stainless steel doors with strong continuous hinge and are field reversible for left or right swing
- Insulated doors have a one piece, replaceable seal
- Easy open handle and latch provide positive lock and seal when the door is pushed or slammed shut
- Hidden magnetic door switch cuts power to blower and steam flow to that cavity, when the door is opened
- Pan support racks shall be polished stainless steel and removable for easy cleaning
- Stainless steel condensate collection tray positioned under cavity door
- Electric heating elements are replaceable from the side.
- Split water lines

OPERATION

- Steamer cavity controls are mounted on the front panel for easy access
- Steamer cavity controls include an ON-OFF power touch pad; 60-minute electro-mechanical timer, with continuous steam setting; and READY light which indicates when cavity is ready for steaming.
- Auto-Delime button initiates deliming cycle. DELIME indicator light warns operator of need to delime generator.
- Separate ON-OFF/60 minute timer control with constant steam setting, for each steamer cavity.
- Unit will shut off if water level is low or unit builds too much pressure
- When power switch is turned off, unit automatically blows down the steam generator, to reduce sediment build-up.
- Powerful side mounted blower, which increases steam velocity and provides efficient steam distribution throughout cavity and between loaded pans.
- Electric-heated, rear-mounted steam generator to provide atmospheric steam to the chamber at a temperature of approximately 212°F.
- Steam generator has an electric water sensor.
- Steam generator delivers 2.6 KW (3 pan) or 3.1 KW (5 pan) power input per 2-1/2" deep steam pan.
- 8-10 minutes heat-up time to READY under normal conditions. Cavities are kept warm and ready for instant steam between loads. No cavity warm up required, after READY light comes on.

CAPACITY

Pan Size	3E-SN	5E-SN
12" x 20" x 1"	6 pans	10 pans
12" x 20" x 2.5"	3 pans	5 pans
12" x 20" x 4"	2 pans	3 pans

STANDARD FEATURES

- One year parts and labor warranty*

* For all international markets, contact your local distributor.

E-SN TABLETOP CONVECTION STEAMER

BLODGETT

44 Lakeside Avenue, Burlington, VT 05401 • Phone: (802) 658-6600 • Fax: (802) 864-0183

A City Discount



E-SN TABLETOP CONVECTION STEAMER



APPROVAL/STAMP

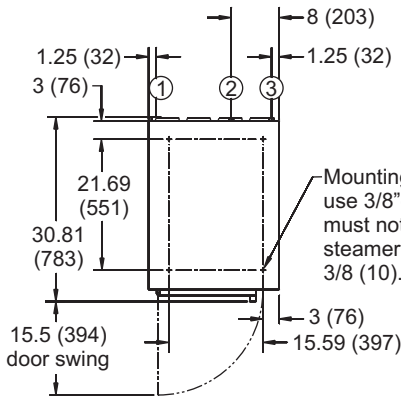

TOP VIEW

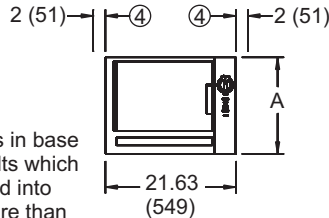

FRONT VIEW

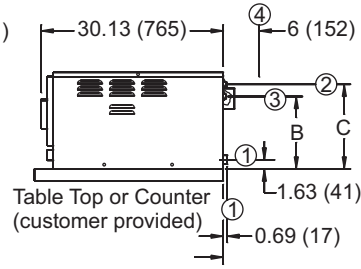

SIDE VIEWS

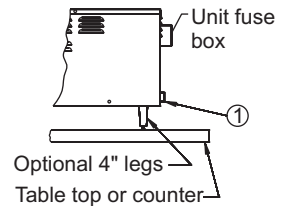

NOTES:

1. Drain connection 1-1/2" tube (drain free venting)
2. Cold water supply at 30-60 PSIG with a flow rate of 0.50-1.00 GPM and with a 3/4" NH connection.
3. One electrical connection: 3/4" conduit fitting. See electrical requirement table.
4. Minimum side and rear clearance.
5. Dimensions are in inches (mm).

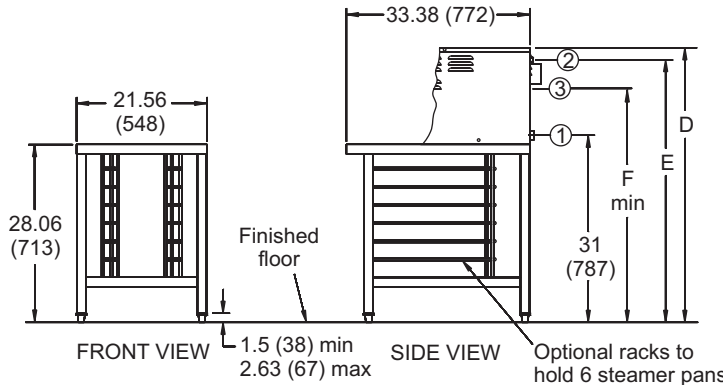

OPTIONAL SUPPORT STAND

REAR OF STEAMER

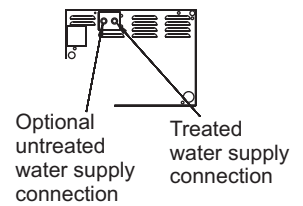

DETAIL VIEW water connections (if second connection ordered)

SHORT FORM SPECIFICATIONS

Provide Blodgett model 3E-SN (3 pan) or 5E-SN (5 pan) pressureless steamer with self-contained, atmospheric electric-heated steam generator. All stainless steel construction, with powerful blower to circulate steam within cavity. Standard operating controls including: 60-minute electromechanical timer, constant steam setting, ready light and delime cycle button to initiate delimiting. Simple generator delimiting through port on top. Door is field-reversible, with easy-open latch and hidden magnetic door switch. The atmospheric steam generator requires no pressure gauge or switches, has automatic drain and 15.5 KW (5E-SN) or 8 KW (3E-SN) power input. Unit shall come up to steam in 8-10 minutes from a cold start, and provide warm cavity instant steam capability and split water lines. Provide options and accessories as indicated.

	3E-SN	5E-SN
A	16 (406)	22.5 (571)
B	12 (305)	15 (381)
C	14 (356)	20.5 (520)
D	45.5 (1156)	50.56 (1284)
E	42.06 (1068)	48.5 (1232)
F	40.06 (1017)	43 (1092)

WATER SUPPLY:

Water quality is a major factor affecting the performance of your steamer. If you are unsure of water quality, consult a local water treatment specialist and have the water analyzed. Your water supply must be within these general guidelines:

Total dissolved solids: Less than 30 PPM Total alkalinity: Less than 20 PPM
 Silica: Less than 13 PPM Chlorine: Less than 1.5 PPM
 pH Factor: 7.0 - 9.0

Water which fails to meet these standards should be treated by installation of a water conditioner. Failure or malfunction of this steamer due to poor water quality is not covered under warranty.

WATER & DRAIN CONNECTIONS:

Drain 1-1/2" NPT free venting drain
 Cold Water Two 3/4" NPT cold water supply lines. Additional cold water connections are provided or spray condenser.
 Appliance is to be installed with backflow protection in accordance with Federal, State or Local codes.

NOTE: The company reserves the right to make substitutions of components without prior notice.

POWER SUPPLY

VAC	Phase	3E-SN		5E-SN	
		Amps	Max kW	Amps	Max kW
208V	1	39	8	74.5	15.5
	3	23	8	44	15.5
240V	1	33	8	64.6	15.5
	3	20	8	38.2	15.5
480V	1	17	8	n/a	n/a
	3	10	8	19.1	15.5

SHIPPING INFORMATION:

Approx. Weight:
 3E-SN 175 lbs. (79 kg)
 5E-SN 210 lbs. (95 kg)

BLODGETT

44 Lakeside Avenue, Burlington, VT 05401 • Phone: (802) 658-6600 • Fax: (802) 864-0183