



SaniServ[®]
An **AFFINIS GROUP** Company

Item No. _____
Quantity _____
Job Name _____

Designed For Higher Volume Applications
Seven - 4 oz. Servings per Minute - 20-Quart Capacity
Great for Restaurants, Buffets, & Ice Cream Shops

Model 404
Countertop
Soft Serve Ice Cream /
Yogurt Machine

The **SaniServ** Model 404 Soft Serve and Frozen Yogurt Machine provides the highest volume of frozen product in a countertop design in the SaniServ product lineup. The high production and quick recovery time of the 404 insures customers are always supplied with their favorite frozen treats and the ease of operation always makes the 404 a favorite among high volume owners and operators!

Space Saving

Small Footprint Design - **SaniServ** model 404 saves valuable floor space and turns the countertop into a real profit center by serving a high volume of high profit ice cream and yogurt products.

Easy Cleaning and Operation

Fewer Parts = Simplified Cleaning - **SaniServ** equipment is designed and built with the fewer parts to be disassembled, cleaned and sanitized than any other machine in the industry.

High Return on Investment

Increased Profits - **SaniServ** machines combine efficiency with consistent product quality and fast quiet operation while insuring customer satisfaction with high profit ice cream or yogurt products.

Quality Design

Durability - **SaniServ** machines are built to achieve long and dependable life through simplicity of design. Every machine is shipped standard with a stainless steel exterior, durable steel interior frame construction, heavy-duty components and consistency systems.



Made in the USA

Model 404

Counter Model Frozen Beverage Freezer

For sales information contact:

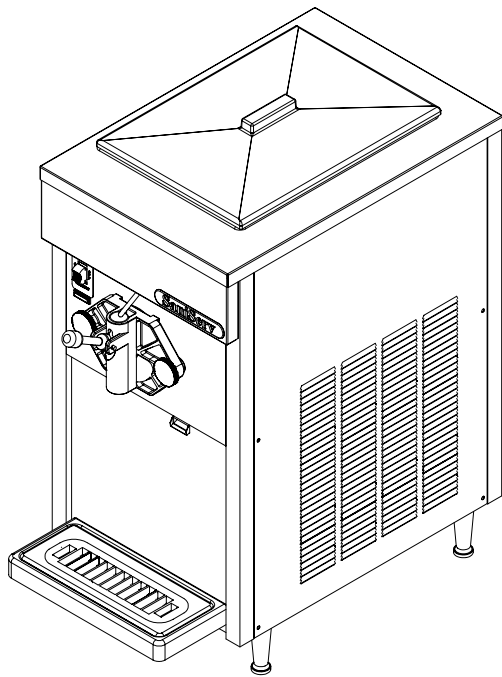

Minimum Wall Clearance
 Both Sides and Back -
 6 inches (152.4 mm)

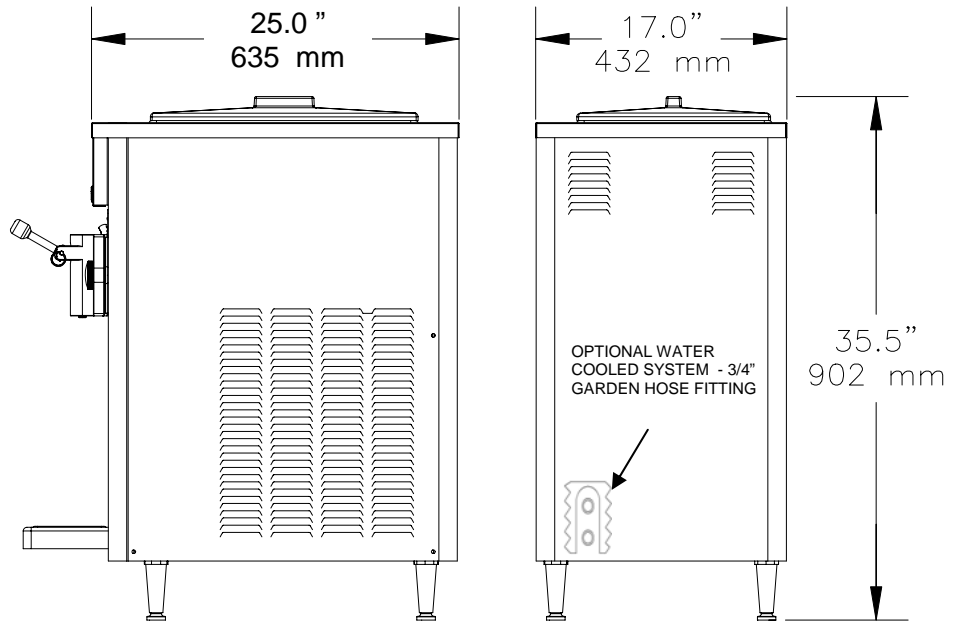

	WIDTH INCHES (mm)	HEIGHT INCHES (mm)	DEPTH INCHES (mm)	VOLTS	HZ	PHASE	AMPS
MACHINE	17.0 (432)	35.5 (902)	25.0 (635)	208-230	60	1	20
MACHINE	17.0 (432)	35.5 (902)	25.0 (635)	208-230	60	3	15
MACHINE CRATED	22.5 (572)	38.0 (965)	34.5 (876)				

Quick Recovery...
Compact and Durable...
Simple in design for easy
cleaning...
Heavy duty components...

Controls: Automatic consistency controls for improved product consistency.

Easy adjustments and an **Automatic Visual Mix Out System** for the protection of your investment.

Electrical: 208-230/60 Hz/1Ø/20 Amp
 208-230/60 Hz/3Ø/15 Amp

Evaporator and Mix Reservoir Capacity: 20 Quarts (18.9 liters)

Construction: Welded Steel Support, Stainless Steel Exterior, Legs Standard, Counter Top Mounting Pad Optional

Dasher: Heavy-Duty Stainless Steel with low friction scraper blades

Dasher and Compressor Motors:
 1/2 HP Dasher 2 HP Compressor

Approximate Weight: 300 lbs. (136 kg)
 with crate: 340 lbs. (155 kg)

Compressor Warranty: Five years

We reserve the right to change specifications and product design without notice. Such revisions do not entitle the buyer to corresponding changes, improvements, additions or replacements for previously purchased equipment.