



Outperform every day.™

Project:

Item Number:

Quantity:

Vacuum Packing Machine with Dual 16" Sealing Bars

The Vollrath Company, L.L.C.

VACUUM PACKING MACHINE WITH DUAL 16" SEALING BARS



Vacuum Packing Machine with Dual 16" Sealing Bars

DESCRIPTION

The Vollrath Vacuum Packing Machine with Dual 16" Sealing Bars provides versatile, high-quality vacuum packing in a small footprint tabletop machine. Liquid Sensor Control helps ensure moist or liquid products can be packed without degrading the product or damaging the machine. Additional features such as Vacuum Plus and Soft-Air enable the user to adjust performance to pack a wide variety of products.

Preset programs can be customized for simple operation and consistent outcomes.

Packing cycle begins when the lid is closed and ends when the lid automatically opens.

Agency Certifications



Due to continued product improvement, please consult www.vollrathco.com for current product specifications.

ITEMS

Item No.	Model No.	Description
40833	VP16	Vacuum Packing Machine with Dual 16" Sealing Bars

FEATURES

- Busch rotary vacuum pump
- Stainless steel exterior
- Deep drawn stainless steel vacuum chamber with round corners
- Transparent, soft-open lid for monitoring functions
- Dual sealing bars accommodate multiple bags up to 16" (40.6 cm) wide
- Double seals for extra secure bags
- Sealing bars easily remove without tools for cleaning and maintenance
- Includes three insert plates for packing small products
- Includes incline plate for packing liquids and fine powders
- Maximum vacuum is 99.8% (2 m bar)
- Set vacuum function by time or sensor control (% pressure)
- Ten programs include Liquid Control, Soft-Air and Vacuum Plus functions
- Soft-Air reduces damage to delicate foods or the bag
- Liquid Control detects the boiling point, stops the vacuum and advances to the next step to reduce cycle time, produce a better quality product and save the pump from taking on liquids
- Vacuum Plus enables air trapped within a product to escape
- Pump Conditioning program removes moisture and debris from pump
- Two sealing cylinders provide optimal pressure to deliver high-quality seals
- Maintenance reminder
- Includes 4" (10.2 cm) optional legs
- Includes maintenance kit with oil, lid gasket, silicone bar, Teflon® tape and sealing wire
- 6 ft. (182.9 cm) cord with plug
- 2 year warranty

IMPORTANT

- Requires 6" (15 cm) clearance on all sides
- Requires a minimum clearance of 30" (76.2 cm) above the machine
- This machine is not designed for continuous use. Intended maximum use is five hours per day.
- Requires 15 second rest between packing cycles.

WARRANTY: All models shown come with Vollrath's standard warranty against defects in materials and workmanship. For full warranty details, please refer to www.Vollrath.com.

Approvals	Date



Outperform every day.™
www.vollrath.com

The Vollrath Company, L.L.C.
1236 North 18th Street
Sheboygan, WI 53081-3201 U.S.A.
Customer Service: 800.628.0830
Canada Customer Service: 800.695.8560
Main Fax: 800.752.5620 or 920.459.6573

Technical Services: 800.628.0832
Technical Services Fax: 920.459.5462

A City Discount

VACUUM PACKING MACHINE WITH DUAL 16" SEALING BARS

DIMENSIONS (Shown in inches (cm))

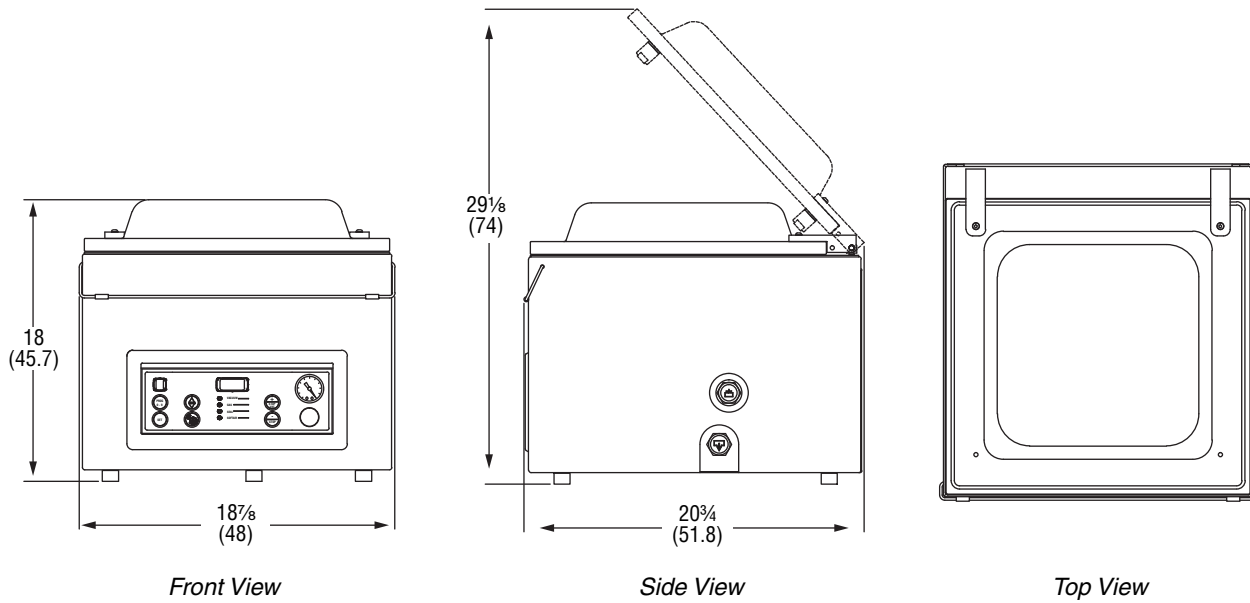

SPECIFICATIONS

Item No.	Dimensions IN (CM)		Volts	Amps	Hz	Pump Capacity	HP	Plug	Weight LB (KG)
	Chamber (W x D x H)	Maximum Product Height							
40833	16 13/16 x 16 1/2 x 5 (42.7 x 41.9 x 12.7)	7 1/2 (19.1)	120	13	60	25 m3/hr	1.3	NEMA 5-20P	136.7 (62)

Receptacle

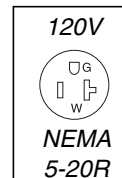

Outperform every day.™

www.vollrath.com

The Vollrath Company, L.L.C.
1236 North 18th Street
Sheboygan, WI 53081-3201 U.S.A.
Customer Service: 800.628.0830
Canada Customer Service: 800.695.8560
Main Fax: 800.752.5620 or 920.459.6573

Technical Services: 800.628.0832
Technical Services Fax: 920.459.5462