



Outperform every day.™

Project:

Item Number:

Quantity:

VACUUM PACK MACHINE WITH DUAL 16" SEALING BARS AND ADVANCED CONTROL SYSTEM

ITEMS

Item No.	Model No.	Description
40834	VPP16	Vacuum Pack Machine with Dual 16" Seal Bars and Advanced Control System

FEATURES

- Busch rotary vacuum pump
- Stainless steel exterior
- Deep drawn stainless steel vacuum chamber with round corners
- Transparent, soft-open lid for monitoring functions
- Dual sealing bars accommodate multiple bags up to 16" (40.6 cm) wide
- Double seals for extra secure bags
- Sealing bars easily remove without tools for cleaning and maintenance
- Includes three insert plates for packing small products
- Includes incline plate for packing liquids and fine powders
- Maximum vacuum is 99.8% (2 m bar)
- Set vacuum function by sensor control (% pressure)
- Advanced Control System features password controlled access; 20 programs with Liquid Control, Soft-Air, Vacuum Plus, Tenderize and label printing functions; and HACCP compliant logging.
- Liquid Control detects the boiling point, stops the vacuum and advances to the next step to reduce cycle time, produce a better quality product and save the pump from taking on liquids
- Vacuum Plus enables air trapped within a product to escape
- Soft-Air reduces damage to delicate foods or the bag
- Compatible with Zebra® LP/TLP 2824 Plus™ label printers
- Pump Conditioning program removes moisture and debris from pump
- Two sealing cylinders provide optimal pressure to deliver high-quality seals
- Maintenance reminder
- Included 4" (10.2 cm) legs required for ETL Sanitation
- Includes maintenance kit with oil, lid gasket, silicone bar, Teflon® tape and sealing wire
- 6 ft. (182.9 cm) cord with plug
- 2 year warranty

IMPORTANT

- Requires 6" (15 cm) clearance on all sides. Requires 12" (30.5 cm) above the machine to allow the lid to open.
- This machine is not designed for continuous use. Intended for maximum use of five hours per day.
- Requires 15 second rest between packing cycles.

WARRANTY: All models shown come with Vollrath's standard warranty against defects in materials and workmanship. For full warranty details, please refer to www.Vollrath.com.



Vacuum Pack Machine with Dual 16" Sealing Bars and Advanced Control System

DESCRIPTION

The Vacuum Pack Machine with Dual 16" Sealing Bars and Advanced Control System.

Agency Certifications



Due to continued product improvement, please consult www.vollrathco.com for current product specifications.

Approvals	Date

Vacuum Pack Machine with Dual 16" Sealing Bars and Advanced Control System The Vollrath Company, L.L.C.



Outperform every day.™
www.vollrath.com

The Vollrath Company, L.L.C.
1236 North 18th Street
Sheboygan, WI 53081-3201 U.S.A.
Customer Service: 800.628.0830
Canada Customer Service: 800.695.8560
Main Fax: 800.752.5620 or 920.459.6573

Technical Services: 800.628.0832
Technical Services Fax: 920.459.5462

VACUUM PACK MACHINE WITH DUAL 16" SEALING BARS AND ADVANCED CONTROL SYSTEM

DIMENSIONS (Shown in inches (cm))

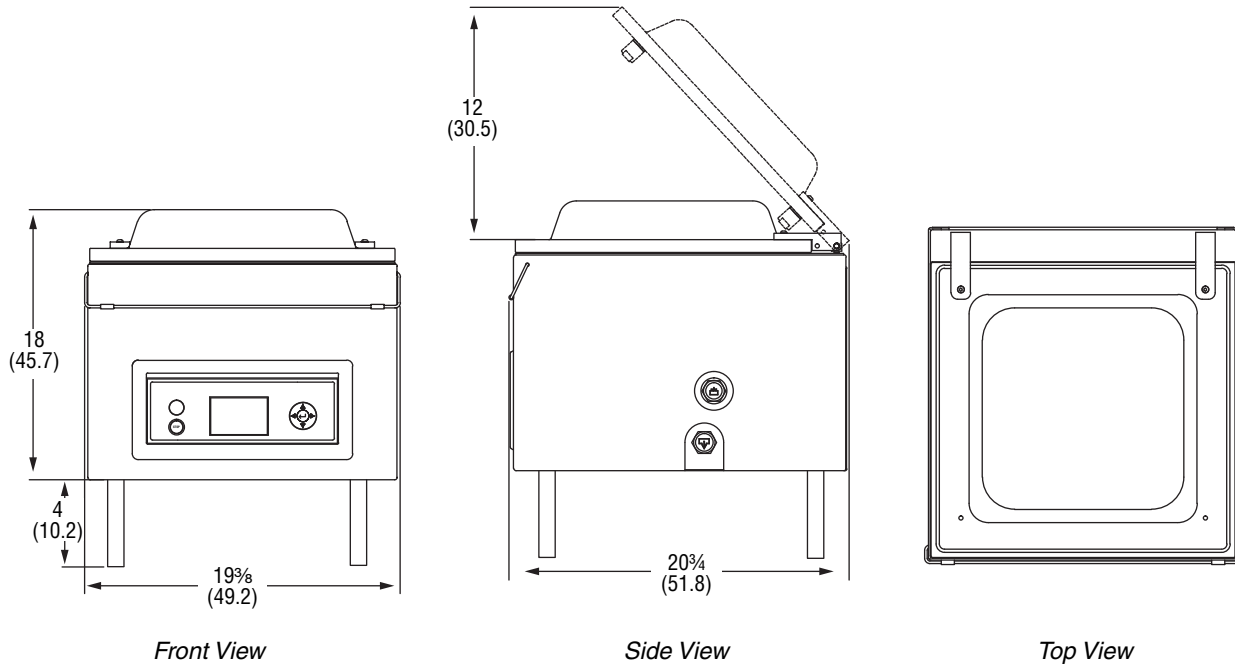

SPECIFICATIONS

Item No.	Dimensions IN (CM)		Volts	Amps	Hz	Pump Capacity GPM (m3/hr)	HP	Plug	Weight LB (KG)
	Chamber (W x D x H)	Maximum Product Height							
40834	16 ^{13/16} x 16 ^{1/2} x 5 (42.7 x 41.9 x 12.7)	7 ^{1/2} (19.1)	120	13	60	92 (25)	1.3	NEMA 5-20P	136.7 (62)

Receptacle

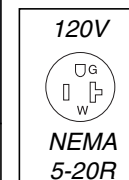

Outperform every day.™

www.vollrath.com

The Vollrath Company, L.L.C.
 1236 North 18th Street
 Sheboygan, WI 53081-3201 U.S.A.
 Customer Service: 800.628.0830
 Canada Customer Service: 800.695.8560
 Main Fax: 800.752.5620 or 920.459.6573

Technical Services: 800.628.0832
 Technical Services Fax: 920.459.5462