

Project Name: _____ AIA#: _____

Model #: _____ Location: _____

SIS#: _____ Item #: _____ Quantity: _____



4600N Premium Heavy-Duty Manual Slicer

Protech™ Premium Model:

4600N Manual Slicer



Made in the U.S.A.

Premium Construction

- 13" *PreciseEdge™* hardened steel alloy knife blade with maximum tip-edge-holding ability
- Exclusive stainless steel construction, with superior corrosion resistance against acids found in fruit, meats and vegetables
- Best of the Best, *EZ-Glide™* slice system
- No-drip base with Marine edge redirects liquids to center of base away from controls and operator
- Precise slice-thickness adjustment, one-piece handle, gear driven and gasket-sealed
- Carriage angle: 45°, full gravity feed
- 2° angled drip groove on the slicer table directs the flow of liquids to the base
- 12" long chute with 3 lb. stainless steel end weight
- Powerful 1/2 HP, 7 amp continuous use motor
- High-performance gear knife drive
- Maintenance-free drive system
- Permanently attached knife ring guard with removable slice deflector

Food Zone Features

- Large stainless steel radii, open space base design for cleaning and simple dismantling of components
- Base has a Marine edge from 1/2" to 3/4" wide and indented areas with 3/16" deep radiused

transition and 3/16" deep internal covered corners.

- Both are integral to the base's work surface
- Knife sharpening system is removable and BPA Free (no-bisphenol-A), immersible, and dishmachine-safe for cleaning and sanitizing
- Moisture proof, easy-to-clean direct contact start/stop touchpad controls
- Sealed splash zones for added sanitation and protection of electronics

Operator Full-featured Protections

- Home position start
- Table lockout- removal of the knife cover locks the slicer table so it cannot be opened. Additionally, the slicer table fully covers the knife edge during cleaning
- Automatic shut-off after 10 seconds
- No voltage release prevents inadvertent reactivation of slicer in the event of power or interlock interruption
- Knife cover interlock prevents slicer from operating without the knife cover in place
- Permanent knife blade ring guard, removable cover and deflector
- Touch pad start/stop controls and power indicator light
- Ergonomic low-profile design reduces operator fatigue
- Kick-stand for cleaning and sanitizing under slicer

Approved by: _____ Date: _____



Premium Heavy-Duty Manual Slicer

4600N

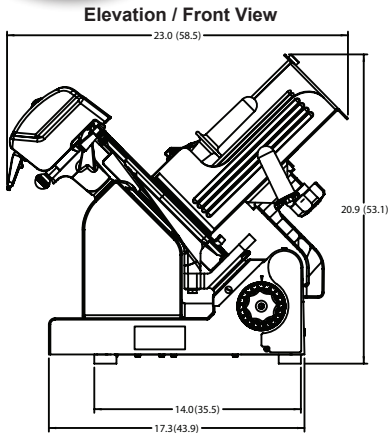

4600N
Side View

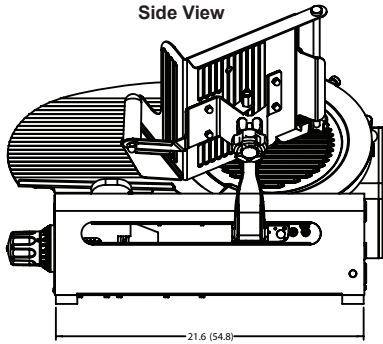

Top View

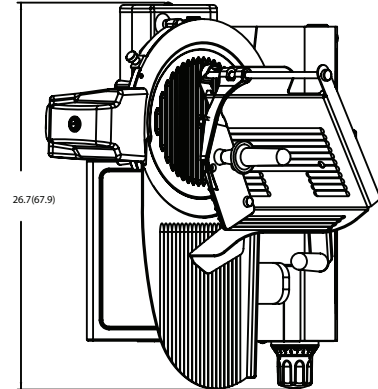

Elevation / Front View with 3" extension legs

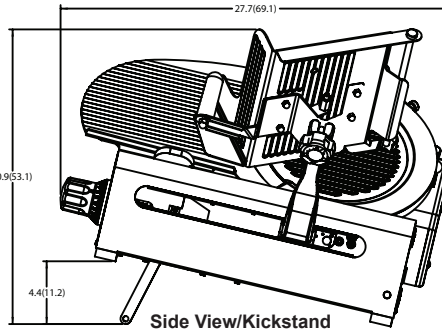
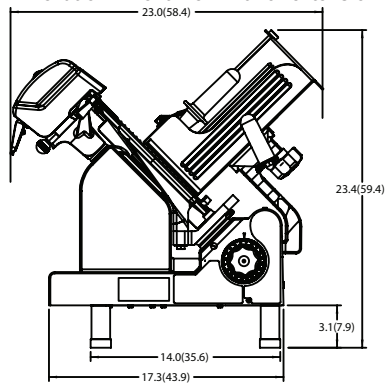



Note: Different chute options will change overall height

Drawings available through KCL. www.kclcad.com

Model	Elevation	Right	Plan	Back	BIM 3D	Revit
4600N						

SPECIFICATIONS

Model	Motor	Volts	Amps	Drive Type	Slicing Volume per Day	Cheese Slicing	Blade Diameter	Max Slice	Product Cutting Capacity		
									D (Diameter)	W (Width)	H (Height)
4600N	1/2 HP	115-60-1	7	Gear	All Day		13" (33.02 cm)	1-1/4" (3.18 cm)	7.5" (19.50 cm)	11.6" (29.46 cm)	9" (22.86 cm)

Cord & Plug: Attached 7 foot flexible 3-wire cord with molded plug fits a grounded receptacle. NEMA 5-15 

FACTORY INSTALLED OPTIONS:

- Quick-Clean™ proprietary non-stick nickel-based coating (knife cover and slice table)
- Dual arm lift lever for easy cleaning
- Correctional package
- High moisture application package (includes 13" stainless steel knife)
- 15" long food chute
- 13" stainless steel knife

SLICER ENHANCEMENT ACCESSORIES:

- Stainless steel low food fence (12" L x 1 3/8" H)
- Stainless steel high food fence (12" L x 3" H)
- 3" extension legs (set of 4)
- 7" D x 14" L Stainless steel vegetable hopper
- Clear plastic slicer cover (Tip: Recommended for preconstruction)
- Additional cleaning brush

WARRANTY:

- 15 years on the knife drive gears
- Two-years parts
- One-year labor

Warranty valid in North America.
Contact factory for warranty in other countries

DIMENSIONS & SHIPPING INFORMATION

Freight Class 77.5

Cartons are reinforced for shipping. The weight and dimensions of this reinforced carton are included below and may vary from shipment to shipment.

Model	Foot Print	Overall Dimensions	Net Weight	Shipping Dimensions	Shipping Weight
4600N	14" D x 21.6" W (35.5 cm x 54.8 cm)	26.7" L x 23" W x 20.9" H (67.9 cm x 58.5 cm x 53.1 cm)	112 lbs. (50.8 kg)	28" L x 25" W x 28" H (71 cm x 63.5 cm x 71 cm)	143 lbs. (65 kg)