



STAR-MAX[®] CHROME GAS GRIDDLES

Models 624TCHSD, 636TCHSD & 648TCHSD

Features/Benefits:

- ★ Star-Max Chrome Gas Griddles feature a 3/4" hard chrome surface providing superior cooking performance and even heat distribution.
- ★ Highly polished chrome surface reflects heat inward reducing radiant heat, lowering energy cost 30% and keeping the kitchen cooler.
- ★ Easy to clean chromium surface reduces labor costs up to 50% by sealing the surface and eliminating food build-up.
- ★ The non-porous chrome surface eliminates food taste transfer for maximum cooking performance.
- ★ Throttling thermostat adjusts from 150° to 450°F providing quick response to temperature change.
- ★ Available in 24", 36" and 48" widths to meet your space and volume requirements.
- ★ High performance 28,300 BTU aluminized steel U-shaped burner every 12" of cooking surface provides superior cooking performance and even heat distribution.
- ★ Heavy-duty body construction with stainless steel front, side panels, bull nose and 4-1/2" high tapered splash guard.
- ★ Automatic safety pilot for each burner assures easy operation and safety.
- ★ Spatula wide 3-1/4" front grease trough and grease chute for easier cleaning.
- ★ Large 4-1/2 quart stainless steel grease drawer.
- ★ Gas convertible in the field, conversion kit supplied. Units are shipped Natural Gas.
- ★ Heavy-duty 4" adjustable legs to fit your countertop line-up requirements.



Model 636TCHSD



Model 648TCHSD
with Optional Equipment Stand
and Casters

Applications:

Breakfast, lunch or dinner, Star's Star-Max Chrome heavy-duty gas griddles support your menu need in any foodservice venue while saving energy, labor and cleaning costs.

Quality Construction:

Star-Max Chrome Gas Griddles feature 3/4" thick steel plate with chromium surface with 4-1/2" high wrap-around stainless steel splash guard and 3-1/4" wide front access grease trough with 4-1/4 quart grease drawer capacity. Includes a 28,300 BTU aluminized steel burner every 12" of width controlled by a thermostatic control valve with standing pilot light, 3/4" N.P.T. male gas connection with convertible pressure regulator, and 4" adjustable legs. These units are approved for installation within 6" of non-combustible surfaces. Griddles operate on Natural or Propane gas.

Warranty:

Star-Max Chrome Gas Griddles are covered by Star's one year parts and labor warranty. In addition, the chrome surface has a limited five year warranty.



Star-Max[®] Chrome Gas Griddles



STAR-MAX® CHROME GAS GRIDDLES

Models 624TCHSD, 636TCHSD & 648TCHSD

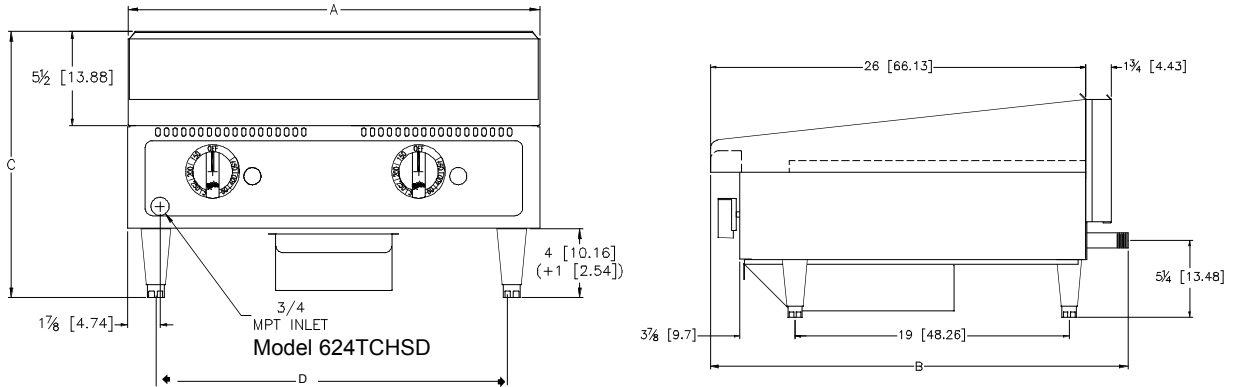

Specifications

Model No.	Dimensions				Number of Thermostats	BTU	Grid Area	Plate Thickness Inches (cm)	Weight	
	(A) Width Inches (cm)	(B) Depth Inches (cm)	(C) Height Inches (cm)	(D) Leg Width Inches (cm)					Installed lbs. (kg)	Shipping lbs. (kg)
624TCHSD	24 (61.0)	29 (73.7)	15-1/2 (39.4)	20-3/4 (52.7)	2	56,600	498 sq. in. 3213.1 sq cm	3/4 (1.9)	151 (74.8)	175 (79.4)
636TCHSD	36 (91.4)	29 (73.7)	15-1/2 (39.4)	32-3/4 (83.2)	3	84,900	747 sq. in. 4819.6 sq cm	3/4 (1.9)	247 (112.0)	262 (118.8)
648TCHSD	48 (121.9)	29 (73.7)	15-1/2 (39.4)	44-3/4 (113.7)	4	113,200	996 sq. in. 6426.2 sq cm	3/4 (1.9)	330 (149.7)	350 (159.0)

Units operate on natural or propane gas.

Typical Specifications

Gas griddles are constructed of stainless steel panel with black polycarbonate trim and double wall aluminized steel side panels. Griddle plate is 3/4" (1.9 cm) thick and has a hard chromium surface. This surface is warranted for a period of 5 years. Plate is 24" (61.0 cm), 36" (91.4 cm), or 48" (121.9 cm) wide and has a 4-1/2" (3.5 cm) tapered high wrap-around stainless steel splash guard. Unit has a 3-1/4" (8.3 cm) wide front grease trough with grease chute and a 4-1/2 quart (4.3 L) stainless steel grease drawer. Griddle is heated by a 28,300 BTU aluminized steel burner for every 12" (30.5 cm) of griddle width and is controlled by a throttling type thermostat. Thermostat knobs are protected by a stainless steel bull nose front. An automatic safety pilot is provided for each burner. Griddles are supplied with 4" (10.2 cm) high die cast nickel plated legs that have a 1-3/8" (3.5 cm) adjustment. Gas connection is 3/4" (1.3 cm) N.P.T. male and a convertible pressure regulator is provided. Units are approved for installation within 6" (15.2 cm) of combustible surfaces and are UL Gas certified and UL Sanitation approved. Printed in the U.S.A.

Due to periodic changes in designs, methods, procedures, policies and regulations, the specifications contained in this sheet are subject to change without notice. While Star Manufacturing exercises good faith efforts to provide information that is accurate, we are not responsible for errors or omissions in information provided or conclusions reached as a result of using the specifications. By using the information provided, the user assumes all risks in connection with such use.

Star Manufacturing International Inc. - 10 Sunnen Drive - P.O. Box 430129 - St. Louis, MO 63143-3800

Phone: (800) 264-7827 - FAX: (800) 264-6666 - www.star-mfg.com