

## SM-6490H

FROZEN BEVERAGE FREEZER

### PRODUCT INFORMATION

Type	Counter Top
Flavors	1
Cooling	Air Cooled
Freezing Cylinders	1x 3.8 L / 4.0 qt
Product Mix Hoppers	1x 25.0 L / 26.4 qt
Output (8oz Servings)	22 qt / hr 89 servings / hr
Motor	1x 0.33 HP, 250W
Compressor (Main)	1x 6000 BTU, R404A
Compressor (Auxilliary)	Solenoid

### FEATURES

Machine Controls	Dual, Analog
Refrigerated Hopper	Yes
Hopper Agitator	Yes
Temperature Display	No
Standby Mode	Yes
Low Mix Indicator Light	Yes
Low Mix Indicator Alarm	Yes
Low Temperature Protection	No
Motor Amperage Protection	Yes, Mechanical
High Pressure Protection	Yes
Thermal Overload Protection	Yes

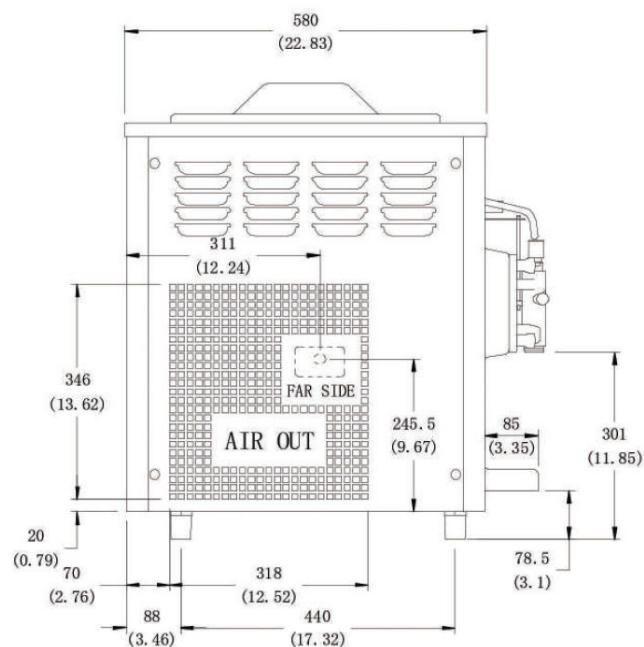
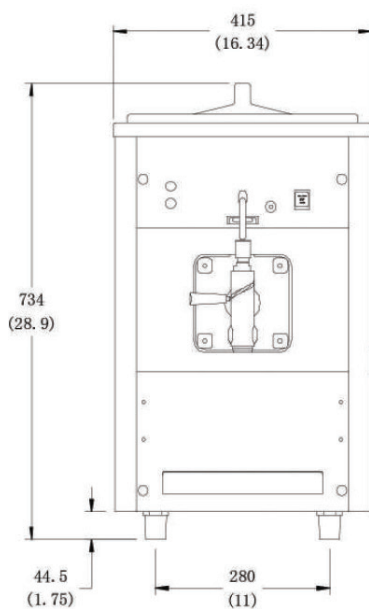

### DESCRIPTION

A medium capacity single flavor counter top frozen beverage freezer. Designed to produce a variety of frozen beverages including: Margaritas, Daiquiris, Fruit Juices, Slushies, etc. Automated analog control system automatically regulates and maintains consistent product quality. Refrigerated hopper and Standby Mode allows product to stay fresh, and allows the machine to be used with dairy products.

### CUSTOM OPTIONS

*Air Chute, Light Box, Spinner (1)*

### ELECTRICAL SPECIFICATIONS

	Maximum Fuse Size	Min. Circuit Ampacity	Poles (P) Wires (W)
110-120/60/1	1 x 20A	1 x 18A	2P / 3W

*Electrical Plug: 1x NEMA 5-20*

### SIZE SPECIFICATIONS

	Machine		Shipping	
Weight	92 kg	205 lbs	102 kg	221 lbs
Depth (mm / in)	580*	22.9*	740	29.2
Width (mm / in)	415*	16.4*	560	22.1
Height (mm / in)	734	28.9	910	35.9

*Shipping Volume: 0.39 CBM / 13.32 CBF*

*\* Machine Requires Minimum 6" Clearance on all sides*