

Breakfast / Snack Carts

Stainless Steel

Models 764, 768



Model 768
Shown with optional hot and cold wells, and menu sign.

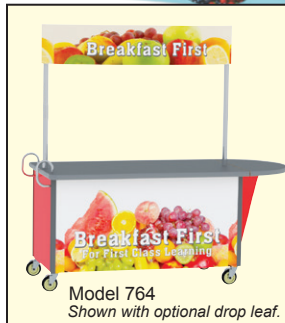

Model 764
Shown with optional drop leaf.



Optional warming/ chilled/utility drawers



Optional height-adjustable wicker baskets mount to support posts.

Add Mobility And Flexibility To Condiment Serving

Benefits

- Provide nutritious breakfast and snacks in various locations
- Rolls easily to serving location
- Colorful graphics attract students

Features

- Stainless steel welded cabinet with laminate top
- Variable-height overhead graphic banner
- Choice of standard or custom laminate finishes and graphics
- 33" high cash register shelf (Model 768)
- Ergonomic vertical push handles
- 18" drop leaf with swing-out support (optional on Model 764)
- Spacious interior storage compartment

Casters

- All-swivel 5" cushion tread, 2 with brakes

Standard Front And Top Panel Graphics Choices

 Breakfast First For First Class Learning	 Write Your Own Custom Message! Marker Board	 Breakfast First
 Snack Shack	 Lunch n Munch	 Snack Shack
<i>Custom graphics available.</i>		

Specifications:

Shall be Lakeside model _____ (764, 768) and shall have a 20-gauge stainless steel base cabinet with laminate exterior and top and stainless steel interior compartment with 18-gauge floor for ease of cleaning and sanitation. Unit shall feature variable-height overhead panel mounted on 1½" diameter stainless steel support posts to accept merchandising graphics. Panel shall be 12" H x 65" W (39" W on #768). Cart shall have 4 ea. 5" cushion tread casters, all-swivel, 2 ea. with brake. Casters shall be mounted to a 18-gauge stainless steel dolly for extra strength.

Model 768: Shall have dual-height top to accommodate cash register and 18" rounded dropleaf (33" height) with swing-out support.

Spec. #

A/A #

Lakeside Manufacturing, Inc.

4900 West Electric Avenue • West Milwaukee, WI 53219 U.S.A.

800-558-8565 • 414-902-6400 • Fax 414-902-6446 • info@eLakeside.com • www.eLakesideFoodservice.com

Breakfast / Snack Cart

Models 764, 768

Stainless Steel

Spec. #

AIA #

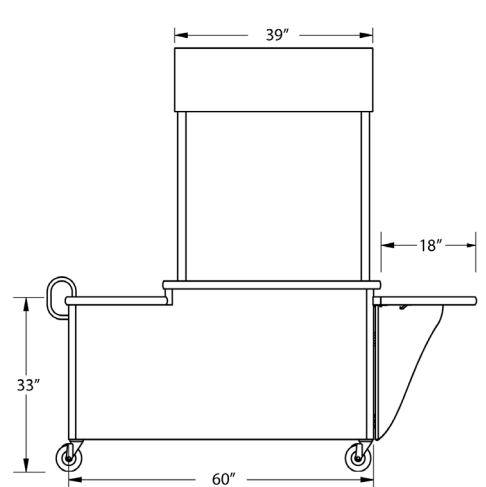
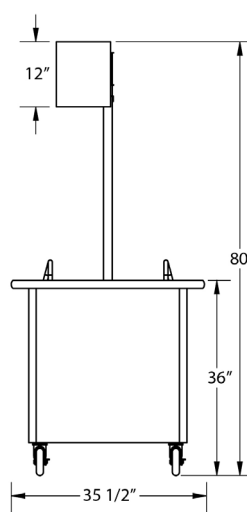
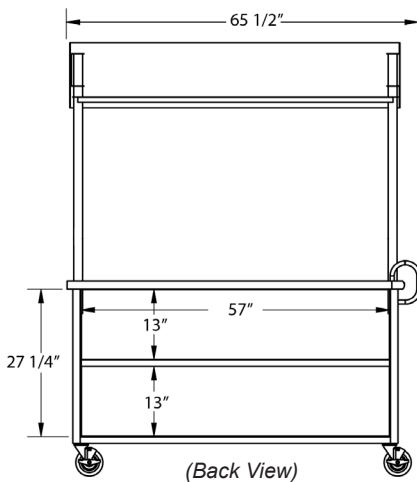
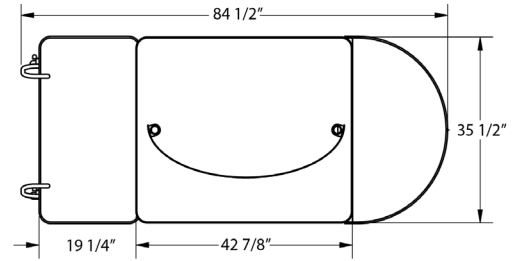
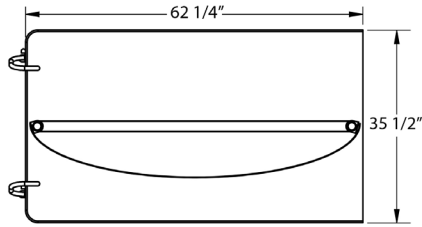

Model 764

Model 768

Model Information:

Model	Description	Counter Height	Top Size		Overall Size			Case Wt. Lbs. (Kg)
			W	L ¹	W	L ²	H ³	
764	Flat Top	36" (927)	35 1/2" (902)	62 1/4" (1581)	35 1/2" (902)	65 1/2" (1664)	80" (2032)	239 (108.4)
768	2-Level Top w/Drop Leaf	Top 36" (927) Cashier Shf. 33" (832)	35 1/2" (902)	62 1/4" (1581)	35 1/2" (902)	84 1/2" (2146)	80" (2032)	260 (117.9)

Dimensions in () denote metric millimeters, unless otherwise noted. Please specify laminate choice.
¹With leaf down. ²With leaf up (#768). ³With support posts fully extended.

Available Laminate Finishes



Walnut Gray Sand Light Maple Victorian Cherry



Beige Suede Hard Rock Maple Red Maple Red Green Black Royal Blue Purple

Options:

- Overhead LED light strip (120V)
- Battery pack for LED light strip
- 18" drop leaf (Model 764)
- Warming drawer(s) ___
- Eutectic chilled drawer(s) ___
- Custom graphics
- Heated well(s) ___
- Eutectic chilled well(s) ___
- Custom laminate
- Utility drawer(s) ___
- Menu sign



MOVING FOODSERVICE FORWARD™

Lakeside Manufacturing, Inc.

4900 West Electric Avenue • West Milwaukee, WI 53219 U.S.A.
 800-558-8565 • 414-902-6400 • Fax 414-902-6446
 info@eLakeside.com • www.eLakesideFoodservice.com