

E**SPACE SAVING SERIES
ELECTRIC STANDARD DEPTH
CONVECTION OVEN**JOB NAME: _____
ITEM NO.: _____
NO. REQUIRED: _____**MODELS:** 8000 (*Single Oven*)
 8092 (*Stacked Oven*)**SIZE:** **8000 Single Oven**
34" High x 34" Wide x 40-1/4" Front-to-Back
(864mm High x 864mm Wide x 1022mm Front-to-Back)
62" High (1575mm) with Stand **8092 Stacked Oven**
74" High x 34" Wide x 40-1/4" Front-to-Back
(1880mm High x 864mm Wide x 1022mm Front-to-Back)**Oven Interior Dimensions:**24" High x 29" Wide x 22-1/2" Deep
(61mm High x 737mm Wide x 572mm Deep)**DESCRIPTION:**

The Market Forge Space Saver Electric Standard Depth Convection Oven is designed to have a small foot print. This space saving oven reduce energy costs and provide superior cooking with five racks and even heat distribution.

Design engineered air circulation system combined with 9kW per oven adds up to more product in less time. This oven has energy savings in mind at all times.

The 8000 Single and 8092 Stacked Convection Ovens provide many standard features that are optional in other brands: Standard features include; 3-heating elements for 9kW, two-speed motor -1/2 HP, electrical thermostat adjustable from 150° to 500°F, two speed motor (*to select best air circulation for desired results*), glass door (*right hand side*), two interior lights, 5 chrome plated racks with 11 positions and stainless steel stand.

Oven shall be constructed of stainless steel on front, sides and top. Oven doors swing open 135° for easier access for loading and unloading. Stainless steel handle adds to the rugged construction and beauty in your kitchen. If you are looking for superior quality and commitment to performance, you can rely on the Space Saver Series Convection Ovens.



8000 Single Oven

8092 Stacked Oven

CAPACITY:Each oven compartment will accommodate
(5) 18" x 26" x 1" Sheet Pans**OPTIONAL:**

- Stainless Steel Bottom Shelf (*Single Ovens Only*).
- Glass Door (*Left Hand Side*).
- Bottom Storage Racks for Sheet Pans (*Single Ovens Only - Must be ordered with shelf*).
- Casters Set of 4, 2 with Brakes and Strain Relief.
- 480 Volt, 3 Phase Operation.
- Extra Oven Racks.
- Prison Package (*Consult Factory*).

The manufacturer reserves the right to modify materials and specifications without notice.

SPEC SHEET: S-6096
06/12FOOD SERVICE EQUIPMENT
Standard Depth Electric Oven

AutoQuotes

**MARKET FORGE**
INDUSTRIES INC.

35 Garvey Street • Everett • MA • 02149-4403

Tel: (617) 387-4100 • Toll Free: (866) 698-3188

Fax: (617) 387-4456 (MA and Overseas) • Fax: (800) 227-2659 (Ex. MA)

E-mail: custserv@mfii.com • www.mfii.com

E**SPACE SAVING SERIES
ELECTRIC STANDARD DEPTH
CONVECTION OVEN**

DETAILS & DIMENSION

SERVICE CONNECTIONS**Ship Weight:**

- 8000 Oven 495 lbs.
- 8092 Oven 940 lbs.

Installation Clearance: When installing ovens against combustible or non-combustible surfaces (*rear or side walls*) 0" clearance is required.

Electrically Operated

EP Power Supply - 1-3/8" (44mm) Ø access holes for power supply wires. Use wire suitable for at least 90°C. Normal amps per line wire per oven: 9kW

Volts	1 pH	3 pH
208, 60Hz	43	25
240, 60Hz	38	22
480, 60Hz	--	11

Details of other electrical systems available upon request.

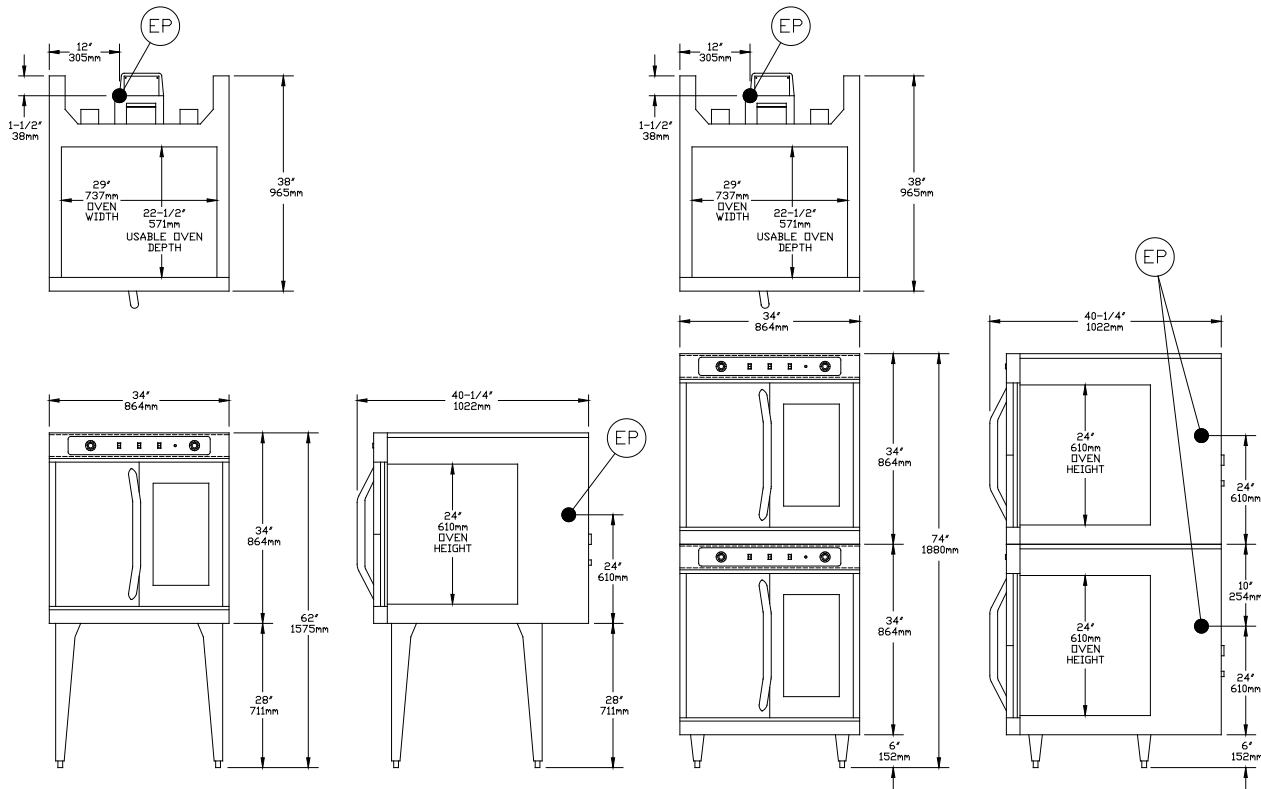
SPEC SHEET: S-6096
06/12FOOD SERVICE EQUIPMENT
Standard Depth Electric Oven

It is our policy to build equipment which is design certified by E.T.L. and N.S.F. However, a continuing program of product improvement makes it necessary to submit new models to the agencies as they are developed and consequently not all models bear the appropriate agency labels at all times.

AutoQuotes

MARKET FORGE
INDUSTRIES INC.

PRINTED IN U. S. A.

35 Garvey Street • Everett • MA • 02149-4403

Tel: (617) 387-4100 • Toll Free: (866) 698-3188

Fax: (617) 387-4456 (MA and Overseas) • Fax: (800) 227-2659 (Ex. MA)

E-mail: custserv@mfii.com • www.mfii.com

A City Discount